

Impacts of Off-Highway Motorized Vehicles on
Sensitive Reptile Species in Owyhee County, Idaho

by
James C. Munger
and
Aaron A. Ames
Department of Biology
Boise State University, Boise, ID 83725

Final Report of Research Funded by a Cost-share Agreement between
Boise State University and the Bureau of Land Management

June 1998

INTRODUCTION

As the population of southwestern Idaho grows, there is a corresponding increase in the number of recreational users of off-highway motorized vehicles (OHMV's). An extensive trail system has evolved in the Owyhee Front, and several off-highway motorized vehicle races are proposed for any given year. Management decisions by the Bureau of Land Management (BLM) regarding the use of public lands for OHMV activity should take account of the impact of OHMV activity on wildlife habitat and populations. However, our knowledge of the impact of this increased activity on many species of native wildlife is minimal.

Of particular interest is the herpetofauna of the area: the Owyhee Front includes the greatest diversity of reptile species of any place in Idaho, and includes nine lizard species and ten snake species (Table 1). Three of these species are considered to be "sensitive" by BLM and Idaho Department of Fish and Game (IDFG): *Sonora semiannulata* (western ground snake), *Rhinocheilus lecontei* (long-nosed snake), and *Crotaphytus bicinctores* (Mojave black-collared lizard). One species, *Hypsiglena torquata* (night snake), was recently removed from the sensitive list, but will be regarded as "sensitive" for the purposes of this report.

Off-highway motorized vehicles could impact reptiles in several ways. First, they may run over and kill individuals. Second, they may collapse burrows, thereby reducing access to subterranean prey and to escape and thermoregulatory locations. Third, OHMV's may alter the habitat by changing the plant community, thereby affecting the availability of prey, of escape locations, and of shady locations.

The objectives of this study are:

1. To develop techniques for studying the impact of off-road vehicles. The typical method used to survey reptiles is the drift fence, which consists of a metal fence 2 feet high and 12 to 50 feet long, with funnel traps along the fence to capture reptiles. However, such fences are highly visible, and to be able to determine the presence of reptiles within feet of off road vehicle trails (where there would be a much higher rate of human visitation and therefore a higher rate of vandalism) required development of more subtle and less visible techniques.
2. To gather preliminary data on the actual impacts of off-road vehicles on the reptile fauna, in particular, to assess impacts on the three sensitive snake species mentioned above. One person working for one summer could not hope to answer all questions associated with the impact of off-road vehicles on reptiles.

METHODS

There are three OHMV trailheads in the Owyhee Front area: Hemingway Butte is the most heavily used, Rabbit Creek receives intermediate use, and Fossil Creek receives the least use. The present study was conducted in the vicinity of the Fossil Creek OHMV trailhead (Figure 1) because (1) it is an area of especially high reptile diversity, (2) it was easy to find unaffected control areas, and (3) we could try our "stealth" traps with less chance for vandalism.

Traditional drift fences are constructed of metal flashing and are very visible from quite a distance. We designed a trapping system that can be used in close proximity to motorcycle trails, but would attract relatively little attention from passers-by. A "fence" consisting of a 2.5 meter long piece of 1/8" mesh hardware cloth (1 ft. wide) buried so that the fence extends above ground level nine inches. Such a piece of hardware cloth is nearly invisible, but still provides a structure that will direct wandering reptiles towards either end of the fence. At each end of the hardware cloth fence we placed a funnel trap (Figure 2), constructed of a 9" diameter aluminum window screen, which had a funnel that narrowed to a 1" opening, and a 20 inch length. Each trap contained a piece of cardboard for shade. Each treatment plot consisted of two fences, one placed 2 m from the trail and one placed 25 m from the trail (Figure 3). For each treatment plot situated next to a trail, we also constructed a control plot located 200 m from the trail; the direction from the trail was determined randomly. In a very few cases, the control pair of fences fell in habitat very different from the next-to-trail treatment pair. For those cases we placed the control pair on the opposite side of the trail. We constructed a total of 26 pairs of plots located on trails varying from narrow (9 to 12 inches wide) motorcycle trails to a two track (Figure 4, Table 2).

We also censused reptiles in sandwashes, using six plots in rocky sandwashes and six plots in sandy washes. In these plots, one fence was placed at or near the center of the wash and the other placed 25 m up the bank (Figure 4). The washes chosen did not contain active OHMV trails, but should be representative of the habitat of impacted washes.

Traps were visited every other day during the first part of the season and every day as the weather grew so hot as to have a high probability of animals succumbing to the heat. Captured animals were identified, measured, then released near the point of capture. It was our experience that 128 fences (which is the size of our study) is at or near the maximum number of fences that can be checked during a day by a single worker. Trapping began on May 28 (see Table 2 for the days each array was active). Traps were disarmed for a week over the July 4 holiday, then rearmed until July 24, 1998.

Statistical Analysis

Our placement of traps at 2,25,200, and 225 m from trails allowed two different comparisons to be conducted. First, on a relatively small scale, we compared captures at the 2 m traps to those at the 25 m trap. Second, at a relatively larger scale, we compared the combined captures at the close pair offences (treatment plot: 2 m and 25 m) to the combined captures at the control pair offences (200 and 225 m). For both comparisons, we used paired t-tests.

RESULTS AND DISCUSSION

We captured a total of 12 reptiles species (5 lizard species and 7 snake species), nearly two-thirds of the species that occur in that geographic area and nearly all of the species that would be expected for such a low desert, arid habitat (Tables 1 and 3). Three of those species not captured (sagebrush lizards, short-horned lizards, rubber boas) tend to be at higher elevations

than our study site. Two other uncaptured species (both the garter snakes) tend to be found near water, which is non-existent on our site. Finally, the western skink is a secretive and relatively rare species, and the Mojave black-collared lizard was observed to be fairly common in certain areas of our study site, but is quite territorial and sedentary and is limited to rock habitat.

It is clear that our "stealth" trap design can capture most of the species present in the area, including the sensitive snake species. However, our fences captured more easily those species that are widely ranging (such as western whiptail lizards and striped whip snakes) but do not do well at capturing highly territorial, relatively sedentary species (such as collared lizards). This is the same trend one would see from traditional drift fences. Because we did not erect traditional drift fences (long, high, and unclimbable), we are not able to make comparisons regarding the effectiveness of shorter, lower, and more climbable "stealth" fences and traditional drift fences.

Effect of Trails

Combined captures of all lizard species and of all snake species showed that proximity to OHMV trails had no detectable effect on numbers of reptiles (Figures 5 and 6). For both groups there was no substantial overall trend, and in some species (e.g., the side blotched lizard, the leopard lizard, and the whip snake) there was actually a trend towards more captures at the 2 m trap than at the 25 m trap (Table 2). This is likely the result of a combination of two factors. First, the trails in our study site are relatively lightly used, so impacts on the reptiles should be less severe. Second, the trails do have at least one positive. Much of the habitat in our study area contains cheat grass (*Bromus tectorum*), which can occur in quite dense stands, making movement by reptiles difficult. OHMV trails open up bare patches that can be traversed relatively rapidly by reptiles. We hesitate to make too much of this potentially positive effect because it would be operative only at low OHMV usage-at higher usage, many of the reptiles attracted to the bare areas would be killed by vehicular passage.

Sensitive Snake Species

Interestingly, for the two snake species deemed as "sensitive" and captured in our traps in OHMV trail treatment and control plots, we detected a negative effect of proximity of OHMV trails-more longnose snakes and night snakes were captured at the pair of fences 200 and 225 m from trails than at the pair of fences 2 and 25 m from trails ($P = .057$ for both species combined; Figures 7 and 8). This is an important result, indicating a potentially detrimental effect of OHMV activity. However, due to the short duration of this study and the relatively small number of animals captured, we urge that this result be confirmed before major management decisions are made.

Washes as habitat

Washes proved to be important habitat for two sensitive snake species (night snakes and ground snakes) and are important for collared lizards as well. Night snakes and ground snakes were more common in or near rock washes (washes with at least some rock substrate on the sides of

the wash) than in or near sandy washes (Figures 9 and 10), probably because the rock habitat provides more hiding places. The two sensitive snake species captured in or near washes differed in their affinities. Western ground snakes were captured only in or near rocky washes, and were more common on the banks of the washes 25 m from the center than in the center of the wash. Night snakes were more common in rock washes than in sandy washes, and were captured more commonly in the center of the wash than on the bank (Figures 7 and 8).

Washes are apparently often used as trails by OHMVs, with the potential to heavily impact reptiles that might use them as habitat. Our findings indicate that (a) western ground snakes were only captured in or near washes, and (b) night snakes were captured at higher densities in washes than at our treatment and control plots. However, both species are nocturnal, and are unlikely to spend the day in the highly unstable substrate of wash bottoms. Therefore, OHMVs that remain in the wash proper should have little impact on ground snakes and night snakes. OHMVs that use bank areas could have substantial impacts on both snake species.

CONCLUSIONS

1. We were unable to detect negative impacts to the reptile fauna when taken as a whole. Possible explanations are: (a) There may have been no actual overall effect of OHMVs on reptiles. (b) We were dealing with trails that receive relatively little traffic; more traffic might have a greater effect. (c) Our trapping was conducted over a two-month period by one individual; we therefore have a relatively small data set which may be too small to detect effects. (d) Positive effects on some species (opening of habitat may favor western whiptails) may obscure negative effects on other species.
2. We have some indication that sensitive snake species, especially long-nosed snakes, are negatively affected by OHMV activity. However, due to our relatively low sample sizes and the short duration of this study, we hesitate to label this finding as definitive.
3. Washes are important habitat, but day use by OHMV s that remain in the unstable portion of the wash are unlikely to have much impact on reptiles, as the reptiles spend the day in burrows or under rocks on the sides of the washes.
4. Our "stealth" design traps are able to capture the reptile species present at the site. They are, however, short and easily climbable, so probably capture fewer reptiles than traditional trapping arrays.
5. A total of 128 fences is at or near the upper limit of what one person can visit in a day.

Table 1. Reptiles that may potentially be found in the Owyhee Front area. Species marked with a "*" were captured during the present study.

Lizards	Snakes
*Western Whiptail (<i>Cnemidophorus tigris</i>)	*Western Rattlesnake (<i>Crotalus viridis</i>)
*Longnose Leopard Lizard (<i>Gambelia wislizenii</i>)	*Striped Whipsnake (<i>Masticophis taeniatus</i>)
Mojave Black-collared Lizard (<i>Crotaphytus bicinctores</i>)	*Gopher Snake (<i>Pituophis catenifer</i>)
Short Horned Lizard (<i>Phrynosoma douglassi</i>)	*Night Snake (<i>Hypsiglena torquata</i>)
*Desert Horned Lizard (<i>Phrynosoma platyrhinos</i>)	W. Terrestrial Garter Snake (<i>Thamnophis elegans</i>)
Sagebrush Lizard (<i>Sceloporus graciosus</i>)	*Racer (<i>Coluber constrictor</i>)
*Western Fence Lizard (<i>Sceloporus occidentalis</i>)	Common Garter Snake (<i>Thamnophis sirtalis</i>)
*Side-blotched Lizard (<i>Uta stansburiana</i>)	*Longnose Snake (<i>Rhinocheilus lecontei</i>)
Western Skink (<i>Eumeces skiltonianus</i>)	*W. Ground Snake (<i>Sonora semiannulata</i>)
	Rubber Boa (<i>Charina bottae</i>)

Table 2. Summary of captures by trap type.

Trap Code:	A	B	C	D	E	F	Total
Traps oriented to:	trail	trail	trail	trail	wash	wash	
Distance of trap from trail or wash	2m	25m	175m	200m	2m	25m	
Species:							
Western Whiptail (<i>Cnemidophorus tigris</i>)	85	111	81	92	22	28	419
Longnose Leopard Lizard (<i>Gambelia wislizenii</i>)	3	0	5	5	0	0	13
Side-blotched Lizard (<i>Uta stansburiana</i>)	10	5	5	10	5	2	37
Desert Horned Lizard (<i>Phrynosoma platyrhinos</i>)	5	0	3	2	0	1	11
Western Fence Lizard (<i>Sceloporus occidentalis</i>)	0	0	0	0	1	0	1
Mojave Black-collared Lizard (<i>Crotaphytus bicinctores</i>)	0	0	0	0	0	0	0
Western Rattlesnake (<i>Crotalus viridis</i>)	1	1	0	0	0	0	2
Western Striped Whipsnake (<i>Masticophis taeniatus</i>)	20	11	15	8	2	3	59
Great Basin Gopher Snake (<i>Pituophis catenifer</i>)	9	10	10	7	3	2	41
Night Snake (<i>Hypsiglena torquata</i>)	0	0	0	2	4	1	7
Western Longnose Snake (<i>Rhinocheilus lecontei</i>)	1	2	4	2	0	0	9
Western Ground Snake (<i>Sonora semiannulata</i>)	0	0	0	0	2	3	5
Totals:	134	140	123	128	39	40	604

tally

Table 3. Summary of captures at the various trapping arrays.

Trap#	traptype	trailtype	days up	elevation (m)	utm	utm	Ct	Gw	Us	Pp	So	Cb	Cv	Mt	Pc	Ht	Rl	Ss	total
00A	***C***	backtrail	34	950	546106	4773398	6	0	0	0	0	0	0	0	0	0	0	0	6
00B	***D***	backtrail	34	949	546087	4773398	3	0	0	0	0	0	0	0	1	0	0	0	4
00C	***A***	frontoffossil	43	965	544642	4772533	5	0	0	0	0	0	0	1	2	0	0	0	8
00D	***B***	frontoffossil	43	966	544661	4772542	5	0	0	0	0	0	0	1	1	0	0	0	7
00E	***C***	frontoffossil	43	958	544783	4772608	8	0	0	1	0	0	0	1	0	0	0	0	10
00F	***D***	frontoffossil	43	956	544803	4772616	12	0	0	0	0	0	0	0	1	0	0	0	13
00G	***A***	frontoffossil	43	963	544580	4772689	8	0	1	1	0	0	0	0	0	0	0	0	10
00H	***B***	frontoffossil	43	964	544558	4772682	14	0	1	0	0	0	0	1	0	0	0	0	16
01A	***C***	frontoffossil	43	967	544428	4772683	4	1	1	0	0	0	0	0	0	0	0	0	6
01B	***D***	frontoffossil	43	967	544404	4772681	5	1	1	1	0	0	0	0	1	0	0	0	9
01C	***A***	frontoffossil	43	967	544543	4772856	5	0	0	0	0	0	0	1	0	0	0	0	6
01D	***B***	frontoffossil	43	966	544563	4772862	7	0	0	0	0	0	0	0	0	0	0	0	7
01E	***C***	frontoffossil	43	972	544687	4772902	5	0	0	0	0	0	0	0	1	0	0	0	6
01F	***D***	frontoffossil	43	973	544710	4772907	6	0	1	0	0	0	0	1	0	0	0	0	8
02A	***A***	connectingtrail	42	964	544696	4772195	2	0	0	2	0	0	0	1	0	0	0	0	5
02B	***B***	connectingtrail	42	968	544673	4772193	4	0	0	0	0	0	0	1	1	0	0	0	6
02C	***C***	connectingtrail	42	971	544551	4772185	7	1	0	0	0	0	0	1	2	0	0	0	11
02D	***D***	connectingtrail	42	971	544532	4772174	3	0	0	0	0	0	0	0	0	0	0	0	3
02E	***A***	connectingtrail	42	961	544727	4771991	0	0	0	0	0	0	0	0	2	0	0	0	2
02F	***B***	connectingtrail	42	961	544705	4771988	9	0	0	0	0	0	0	2	2	0	0	0	13
02G	***C***	connectingtrail	42	955	544857	4771973	6	0	1	0	0	0	0	2	0	0	1	0	10
02H	***D***	connectingtrail	42	958	544874	4771958	4	2	0	0	0	0	0	1	0	0	0	0	7
03A	***A***	connectingtrail	42	962	544750	4771869	0	0	0	0	0	0	0	0	0	0	0	0	0
03B	***B***	connectingtrail	42	961	544729	4771864	0	0	0	0	0	0	0	0	0	0	0	0	0
03C	***C***	connectingtrail	42	961	544642	4771849	3	1	0	0	0	0	0	1	1	0	0	0	6
03D	***D***	connectingtrail	42	966	544618	4771848	6	0	0	0	0	0	0	0	1	0	0	0	7
03F	***A***	connectingtrail	42	964	544788	4771704	1	0	0	0	0	0	0	1	2	0	0	0	4
03G	***B***	connectingtrail	42	963	544810	4771704	2	0	0	0	0	0	0	1	0	0	0	0	3
03H	***A***	connectingtrail	42	966	544822	4771585	3	0	2	0	0	0	0	2	0	0	0	0	7
03I	***B***	connectingtrail	42	966	544844	4771586	6	0	1	0	0	0	0	0	0	0	0	0	7
10A	***A***	rockywash	27	925	545670	4772060	5	0	0	0	0	0	0	0	0	0	0	0	5
10B	***B***	rockywash	27	939	545671	4772081	2	0	0	0	0	0	0	0	0	0	0	1	3
11A	***A***	rockywash	27	922	545738	4772099	4	0	0	0	0	0	0	0	0	3	0	1	8
11B	***B***	rockywash	27	930	545721	4772112	6	0	0	0	0	0	0	0	0	1	0	0	7
12A	***A***	rockywash	27	930	545743	4772189	1	0	4	0	0	0	0	1	1	0	0	1	8
12B	***B***	rockywash	27	919	545761	4772176	3	0	1	0	0	0	0	1	0	0	0	1	6
13A	***C***	connectingtrail	42	965	544941	4771652	2	0	0	0	0	0	0	1	0	0	1	0	4
13B	***D***	connectingtrail	42	964	544962	4771642	2	0	0	0	0	0	0	0	1	0	0	0	3
13C	***C***	connectingtrail	42	968	544968	4771563	5	1	0	0	0	0	0	0	0	0	0	0	6
13D	***D***	connectingtrail	42	967	544990	4771556	1	0	2	0	0	0	0	0	0	0	0	0	3
14A	***A***	trailhead	16	944	544950	4770897	1	0	0	1	0	0	0	1	0	0	0	0	3
14B	***B***	trailhead	16	944	544931	4770882	1	0	0	0	0	0	0	0	0	0	0	0	1
14C	***C***	trailhead	16	949	544795	4770866	0	0	0	2	0	0	0	0	0	0	0	0	2
14D	***D***	trailhead	16	950	544774	4770863	0	0	0	0	0	0	0	0	0	0	0	0	0
14E	***A***	trailhead	16	938	545042	4770759	0	0	0	0	0	0	0	0	1	0	0	0	1
14F	***B***	trailhead	16	940	545025	4770746	1	0	0	0	0	0	0	0	0	0	0	0	1
14G	***C***	trailhead	16	941	544964	4770630	0	0	0	0	0	0	0	0	0	0	0	0	0
14H	***D***	trailhead	16	942	544953	4770609	0	0	0	0	0	0	0	0	1	0	0	0	1
14I	***A***	trailhead	16	953	545125	4770616	0	0	1	0	0	0	0	0	1	0	0	0	2
14J	***B***	trailhead	16	952	545105	4770606	0	0	2	0	0	0	1	0	0	0	0	0	3
15A	***C***	trailhead	16	954	545011	4770532	2	0	1	0	0	0	0	0	1	0	0	0	4
15B	***D***	trailhead	16	953	545009	4770507	4	0	0	0	0	0	0	0	0	1	0	0	5
15C	***A***	trailhead	16	959	545199	4770462	0	0	2	0	0	0	0	0	0	0	0	0	2
15D	***B***	trailhead	16	962	545180	4770451	2	0	0	0	0	0	0	0	0	0	0	0	2
15E	***C***	trailhead	16	963	545132	4770326	3	0	0	0	0	0	0	0	0	0	0	0	3
15F	***D***	trailhead	16	963	545120	4770309	2	0	0	0	0	0	0	0	0	0	0	0	2
15G	***A***	trailhead	16	962	545277	4770311	1	0	1	0	0	0	0	1	0	0	0	0	3
15H	***B***	trailhead	16	960	545259	4770297	0	0	1	0	0	0	0	0	0	0	0	0	1

tally

15I	***C***	trailhead	16	964	545153	4770208	1	0	1	0	0	0	0	0	0	1	0	0	0	3
15J	***D***	trailhead	16	966	545131	4770195	1	0	0	0	0	0	0	0	0	0	0	0	0	1
15K	***A***	trailhead	16	969	545360	4770161	2	0	0	0	0	0	0	0	0	0	0	0	0	2
15L	***B***	trailhead	16	960	545341	4770150	4	0	0	0	0	0	0	1	0	0	0	0	5	
15M	***C***	trailhead	16	963	545252	4770063	1	0	0	0	0	0	0	0	0	0	0	0	1	
15N	***D***	trailhead	16	963	545235	4770049	0	0	0	0	0	0	0	0	0	0	0	0	0	
1A	***A***	twotrack	32	981	544367	4772209	2	0	0	0	0	0	0	0	0	0	1	0	3	
1B	***B***	twotrack	32	979	544374	4772187	1	0	0	0	0	0	0	0	0	0	0	0	1	
1C	***C***	twotrack	32	972	544440	4772025	0	0	0	0	0	0	0	0	0	0	0	0	0	
1D	***D***	twotrack	32	972	544447	4772004	0	1	0	0	0	0	0	0	0	0	1	0	2	
21A	***A***	backtrail	42	884	546529	4773998	8	2	0	0	0	0	0	2	0	0	0	0	12	
21B	***B***	backtrail	42	879	546548	4773984	2	0	0	0	0	0	0	1	2	0	0	0	5	
22A	***C***	backtrail	42	876	546705	4773881	8	1	0	0	0	0	0	1	2	0	0	0	12	
22B	***D***	backtrail	42	875	546712	4773862	5	0	1	0	0	0	0	3	1	0	1	0	11	
22C	***A***	backtrail	42	895	546478	4773852	5	1	0	0	0	0	0	2	0	0	0	0	8	
22D	***B***	backtrail	42	894	546458	4773858	2	0	0	0	0	0	0	0	0	0	0	0	2	
22E	***C***	backtrail	42	901	546377	4773832	3	0	0	0	0	0	0	0	0	0	0	0	3	
22F	***D***	backtrail	42	898	546356	4773830	4	0	0	0	0	0	0	0	0	0	0	0	4	
22G	***A***	backtrail	34	916	546433	4773721	4	0	0	0	0	0	0	0	0	0	0	0	4	
22H	***B***	backtrail	34	915	546451	4773709	5	0	0	0	0	0	0	0	2	0	1	0	8	
22J	***C***	backtrail	34	916	546312	4773796	2	0	0	0	0	0	0	0	0	1	0	0	3	
22I	***D***	backtrail	34	916	546295	4773804	8	0	0	0	0	0	0	1	0	0	0	0	9	
22K	***A***	backtrail	34	921	546394	4773577	3	0	0	0	0	0	0	1	1	0	0	0	5	
23A	***B***	backtrail	34	920	546372	4773581	9	0	0	0	0	0	0	1	0	0	0	0	10	
23B	***C***	backtrail	34	926	546278	4773635	5	0	0	0	0	0	0	1	1	0	0	0	7	
23C	***D***	backtrail	34	926	546256	4773639	2	0	0	0	0	0	0	1	0	0	0	0	3	
23D	***A***	backtrail	34	925	546316	4773450	3	0	0	0	0	0	0	0	0	1	0	0	4	
23E	***B***	backtrail	34	926	546336	4773442	2	0	0	0	0	0	0	0	0	0	0	0	2	
23F	***C***	backtrail	34	929	546473	4773386	0	0	0	0	0	0	0	3	0	0	0	0	3	
23G	***D***	backtrail	34	928	546484	4773369	2	0	0	0	0	0	0	0	0	0	0	0	2	
23H	***A***	backtrail	34	947	546236	4773330	2	0	1	0	0	0	1	1	0	0	0	0	5	
23I	***B***	backtrail	34	944	546217	4773340	3	0	0	0	0	0	0	1	0	0	0	0	4	
25A	***A***	sandywash	16	906	545649	4774316	3	0	0	0	0	0	0	1	1	0	0	0	5	
25B	***B***	sandywash	16	909	545638	4774331	0	0	0	0	0	0	0	0	0	0	0	0	0	
26A	***A***	sandywash	16	906	545605	4774252	0	0	0	0	0	0	0	0	0	0	0	0	0	
26B	***B***	sandywash	16	913	545592	4774265	1	0	0	1	0	0	0	1	0	0	0	0	3	
27A	***C***	sandywash	16	910	545561	4774279	2	0	0	0	0	0	0	0	0	1	0	0	3	
27B	***D***	sandywash	16	916	545569	4774293	0	0	0	0	0	0	0	0	0	0	0	0	0	
28A	***A***	sandywash	16	909	545507	4774255	2	0	0	0	0	0	0	0	0	0	0	0	2	
28B	***B***	sandywash	16	913	545485	4774265	0	0	0	0	0	0	0	0	0	0	0	0	0	
29A	***A***	sandywash	16	911	545491	4774204	2	0	0	0	0	0	0	0	0	0	0	0	2	
29B	***B***	sandywash	16	916	545475	4774212	1	0	0	0	0	0	0	1	0	0	0	0	2	
2A	***A***	twotrack	32	981	544441	4772251	3	0	0	1	0	0	0	2	0	0	0	0	6	
2B	***B***	twotrack	32	980	544434	4772273	2	0	0	0	0	0	0	0	1	0	0	0	3	
2C	***C***	twotrack	32	977	544377	4772387	0	0	0	0	0	0	0	0	1	0	0	0	1	
2D	***D***	twotrack	32	976	544378	4772406	6	0	1	1	0	0	0	0	0	0	0	0	8	
30A	***A***	sandywash	16	913	545465	4774146	1	0	0	0	0	0	0	0	0	0	0	0	1	
30B	***B***	sandywash	16	920	545454	4774158	1	0	0	0	0	0	0	0	2	0	0	0	3	
3A	***A***	twotrack	32	975	544526	4772260	6	0	0	0	0	0	0	0	0	0	0	0	6	
3B	***B***	twotrack	32	977	544518	4772282	12	0	0	0	0	0	0	0	0	0	0	0	12	
3C	***C***	twotrack	32	971	544618	4772148	3	0	0	0	0	0	0	0	0	0	0	0	3	
3D	***D***	twotrack	32	969	544628	4772126	6	0	0	0	0	0	0	0	0	0	0	0	6	
4A	***A***	twotrack	32	955	544801	4772451	4	0	0	0	0	0	0	2	0	0	0	0	6	
4B	***B***	twotrack	32	955	544789	4772468	10	0	0	0	0	0	0	0	0	0	0	0	10	
4C	***C***	twotrack	32	959	544737	4772589	2	0	1	0	0	0	0	3	0	0	0	0	6	
4D	***D***	twotrack	32	958	544727	4772608	2	1	1	0	0	0	0	0	1	0	0	0	5	
5A	***A***	twotrack	32	955	544883	4772482	10	0	0	0	0	0	0	0	0	0	0	0	10	
5B	***B***	twotrack	32	953	544893	4772462	4	0	0	0	0	0	0	0	0	0	0	0	4	
5C	***C***	twotrack	32	952	544978	4772370	2	0	0	0	0	0	0	0	0	0	0	0	2	
5D	***D***	twotrack	32	954	544992	4772353	3	0	2	0	0	0	0	1	0	0	0	0	6	
6A	***A***	twotrack	32	955	544954	4772532	7	0	2	0	0	0	0	2	0	0	0	0	11	

tally

6B	***B***	twotrack	32	956	544938	4772547	4	0	0	0	0	0	0	0	1	1	0	0	0	6
6C	***C***	twotrack	32	959	544825	4772853	3	0	0	0	0	0	0	0	1	0	0	1	0	5
6D	***D***	twotrack	32	957	544811	4772670	5	0	1	0	0	0	0	0	0	0	0	0	0	6
7A	***A***	rockywash	27	936	545486	4772098	1	0	1	0	0	0	0	0	1	0	0	0	3	
7B	***B***	rockywash	27	947	545492	4772118	12	0	0	0	0	0	0	0	0	0	0	0	12	
8A	***A***	rockywash	27	935	545555	4772127	0	0	0	0	0	0	0	0	0	0	0	0	0	
8B	***B***	rockywash	27	942	545536	4772140	1	0	0	0	0	0	0	0	0	0	0	0	2	
9A	***A***	rockywash	27	931	545603	4772097	1	0	0	0	1	0	0	0	0	0	0	0	2	
9B	***B***	rockywash	27	941	545620	4772108	1	0	1	0	0	0	0	0	0	0	0	0	2	
total							419	13	37	11	1	0	2	59	41	7	9	5	604	

Notes:

- 1. Species Ct= Western Whiptail (*Cnemidophorus tigris*)
- Gw= Longnose Leopard Lizard (*Gambelia wislizenii*)
- Us = Side-blotched Lizard (*Uta stansburiana*)
- Pp = Desert Horned Lizard (*Phrynosoma platyrhinos*)
- So = Western Fence Lizard (*Sceloporus occidentalis*)
- Cb = Mojave Black-collared Lizard (*Crotaphytus bicinctores*)
- Cv = Western Rattlesnake (*Crotalus viridis*)
- Mt = Western Striped Whipsnake (*Masticophis taeniatus*)
- Pc = Great Basin Gopher Snake (*Pituophis catenifer*)
- Ht = Night Snake (*Hypsiglena torquata*)
- RI = Western Longnose Snake (*Rhinocheilus lecontei*)
- Ss = Western Ground Snake (*Sonora semiannulata*)

Figure 1a. Overview of Study area, showing arrangement of plots near trails and washes. See 1b and 1c for close-ups of the northeast and southwest portions.

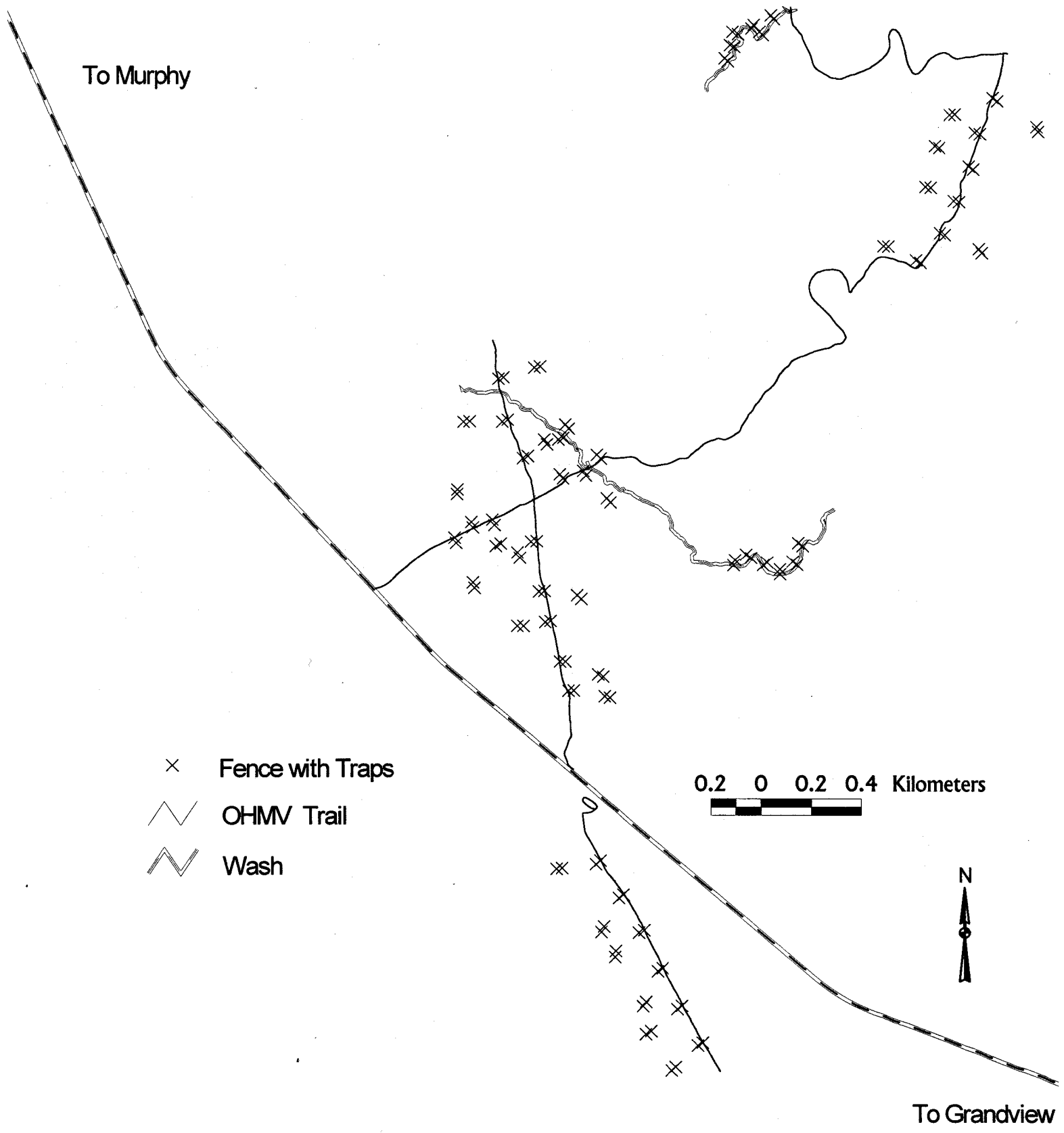

Figure 1b. Close up of northwestern portion of study site showing arrangement of plots near trail and near wash.

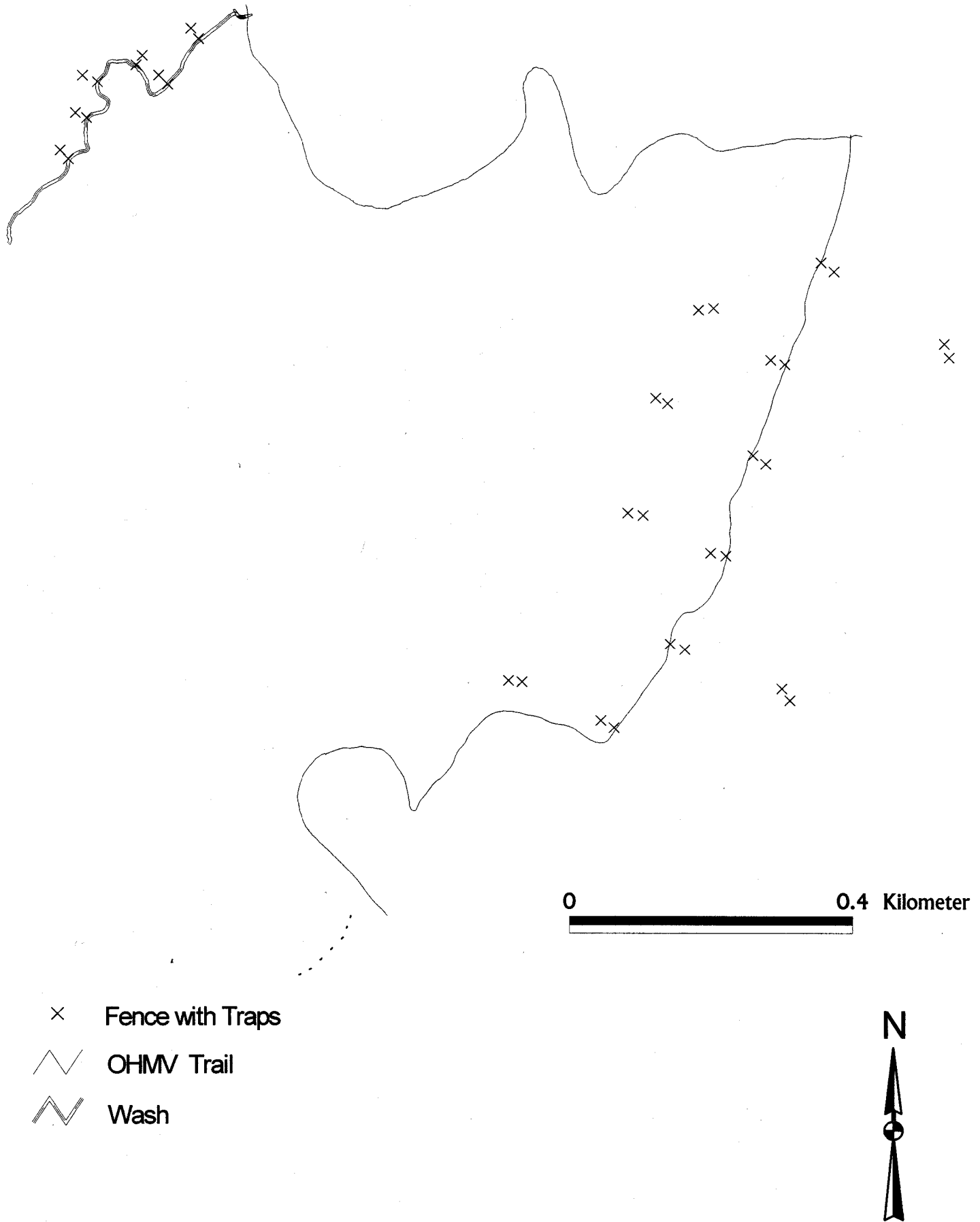

Figure 1C. Layout of the Southwestern Portion of the Study Site.

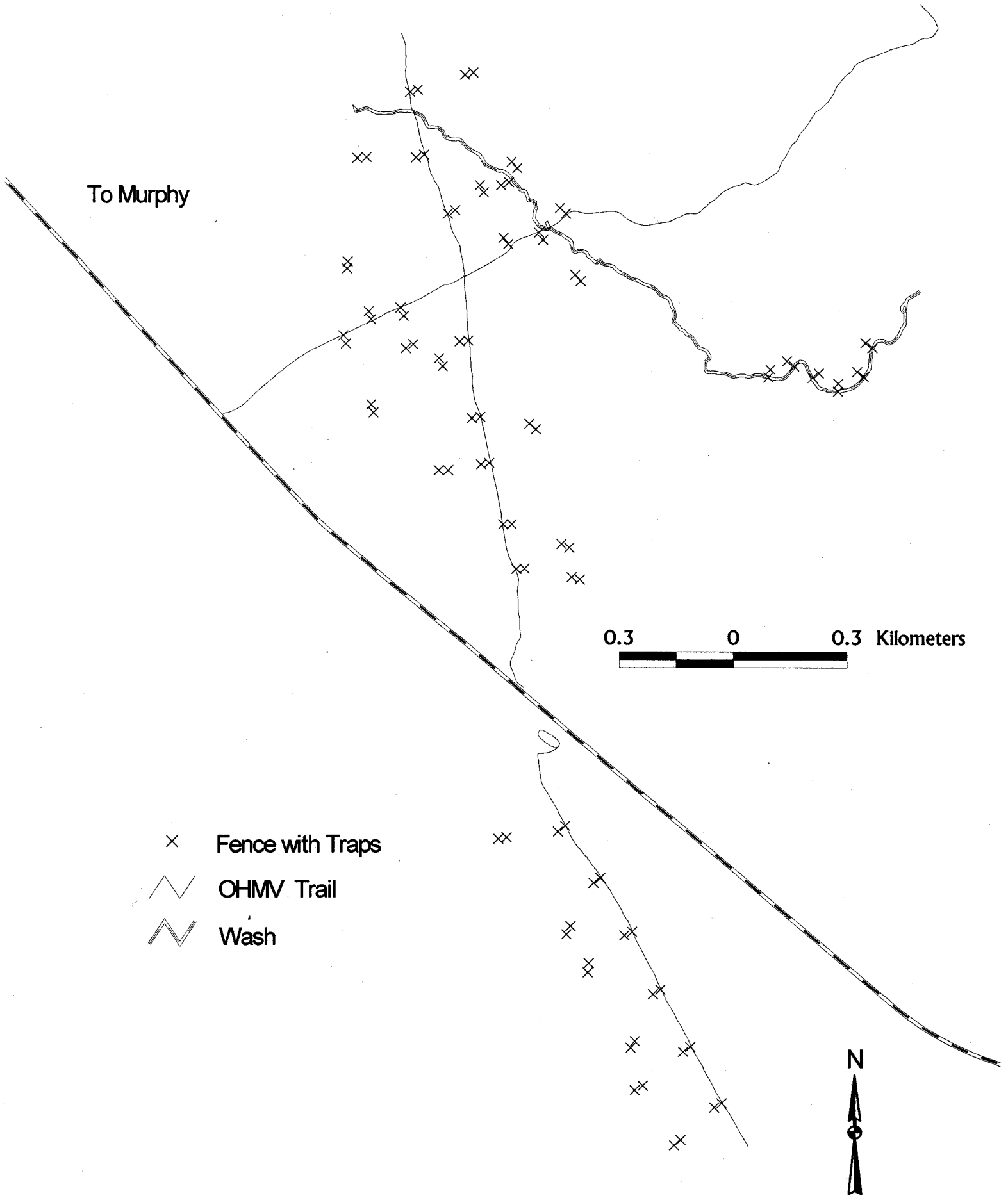

Figure 2a. Placement of traps at end of fence.

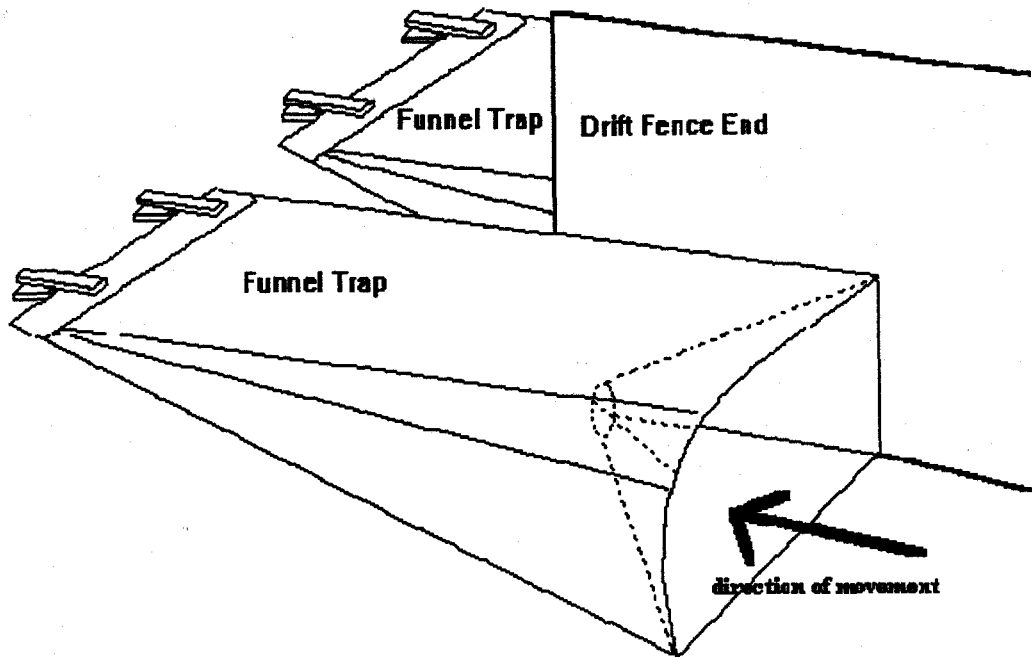

Figure 2b. Overall view of drift fence.

Fence Construction

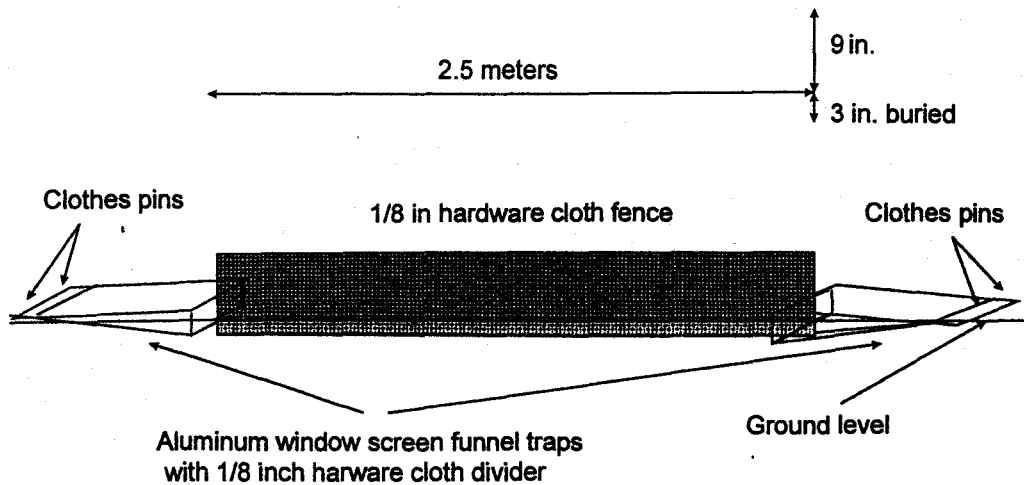

Figure 3. Placement of traps near trails.

Trap Placement

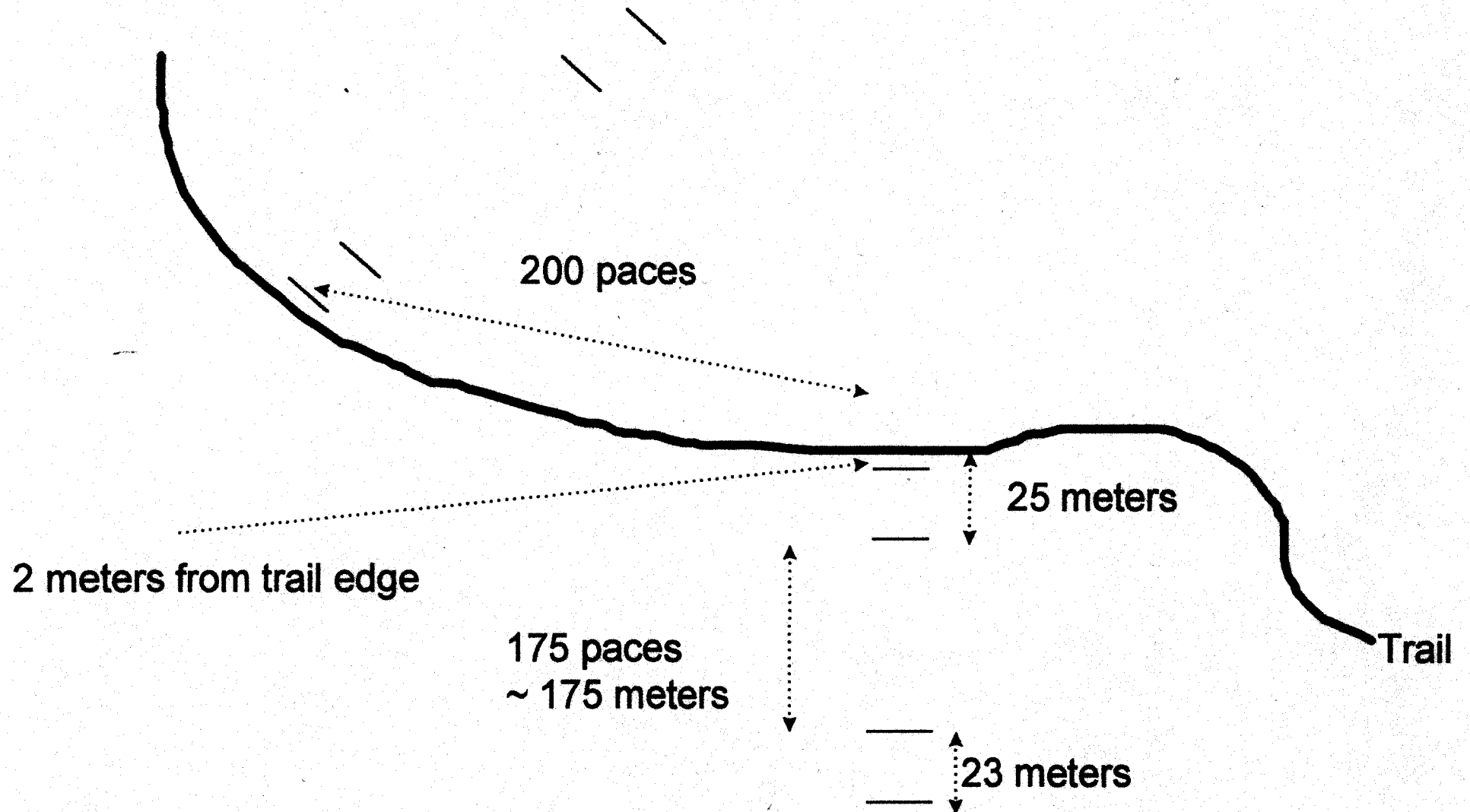

Figure 4a. Overview of Study area, showing arrangement of plots near trails and washes. See 4b and 4c for close-ups of the northeast and southwest portions.

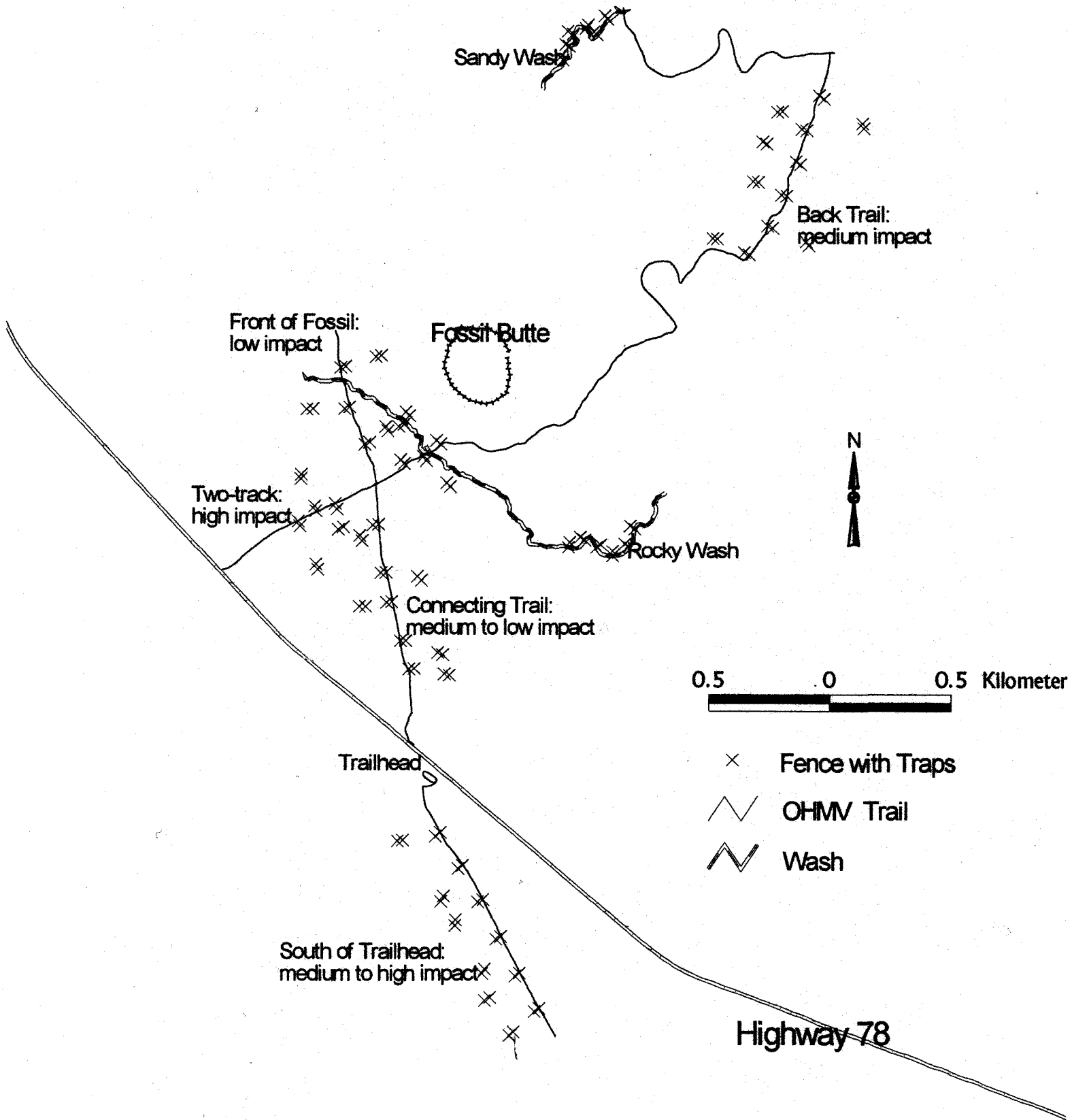

Figure 4b. Close up of northwestern portion of study site showing arrangement of plots near trail and near wash.

Sandy Wash

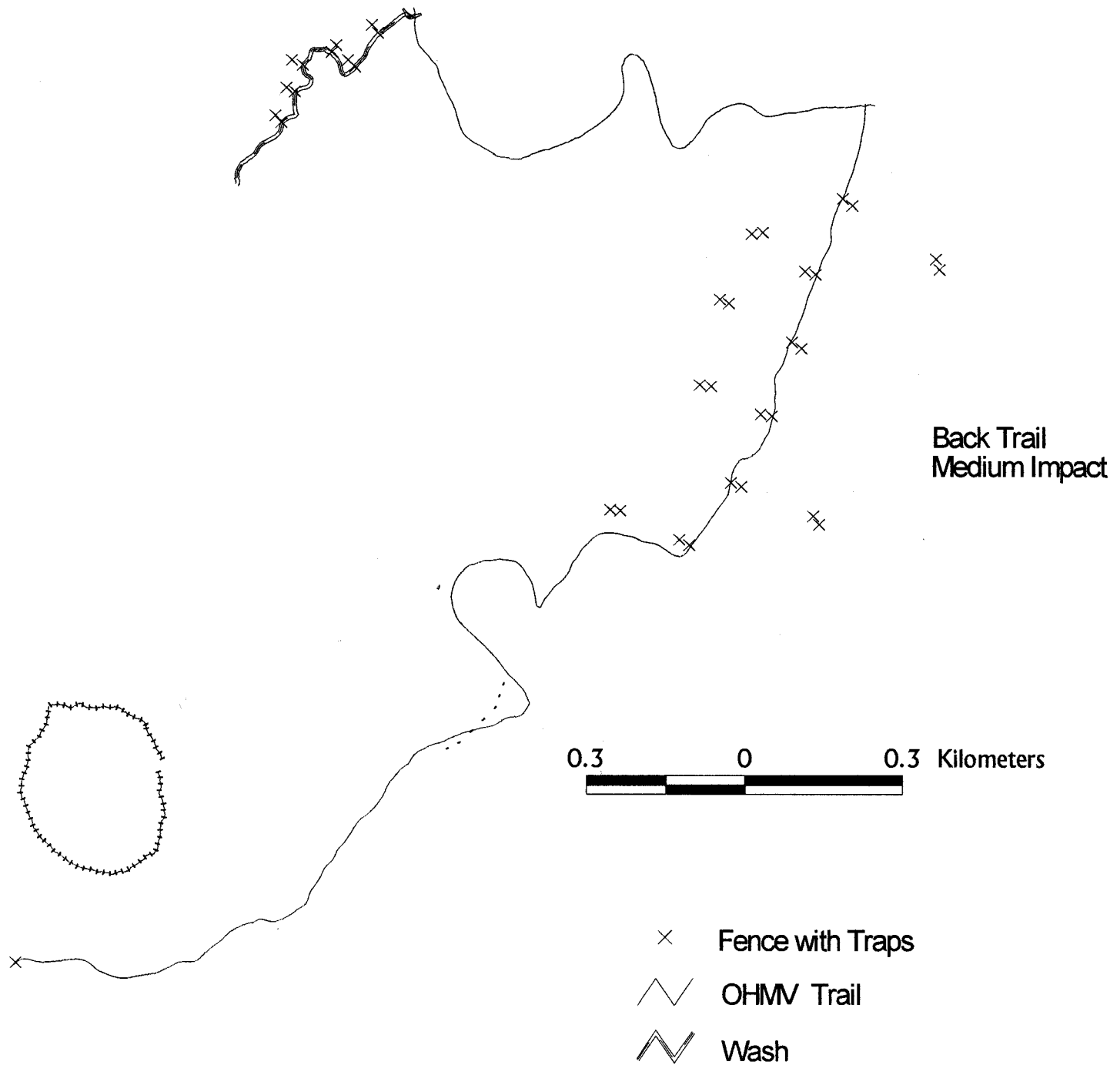

Figure 4C. Layout of the Southwestern Portion of the Study Site.

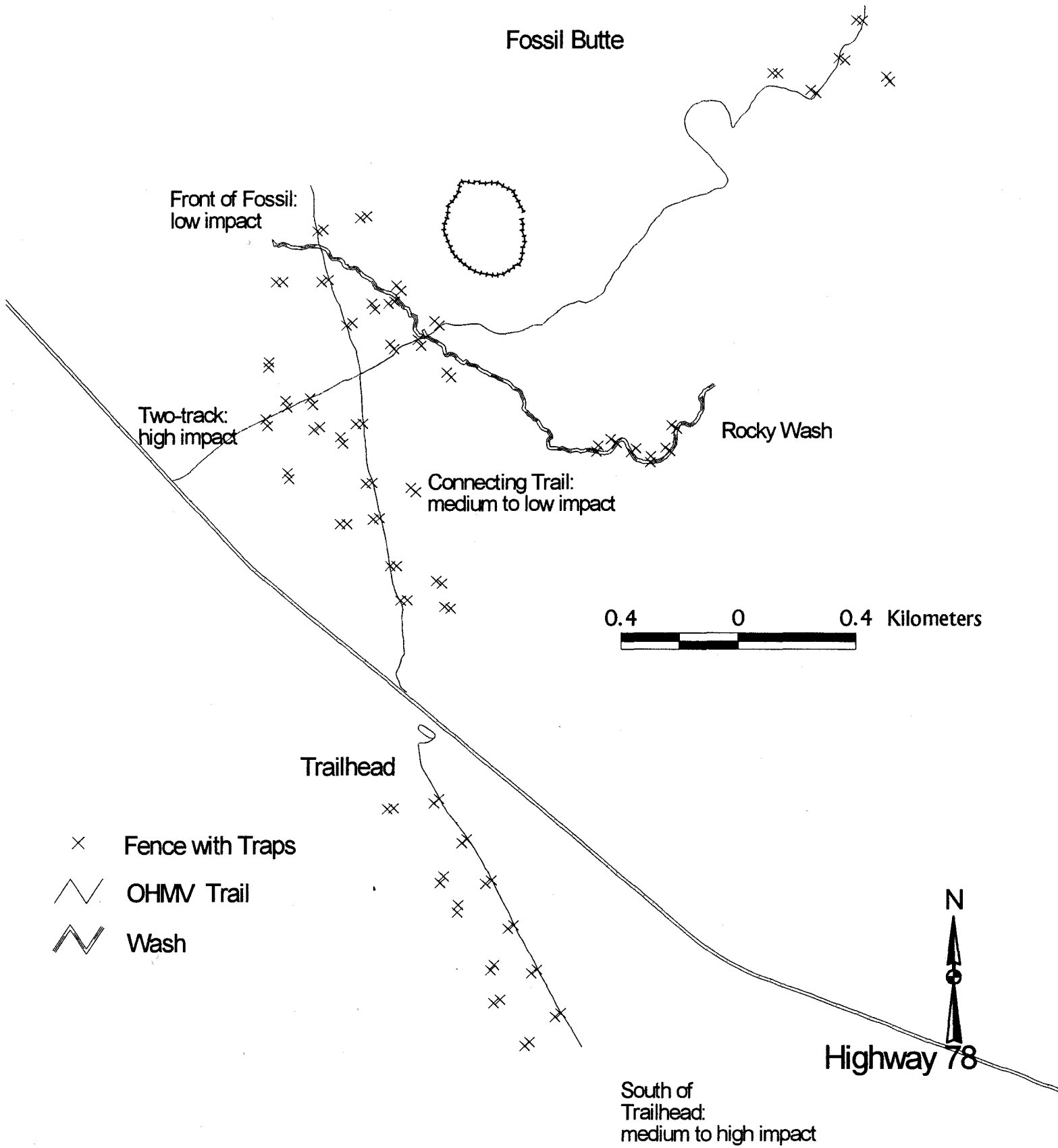

Figure 5a. Snakes: All Species

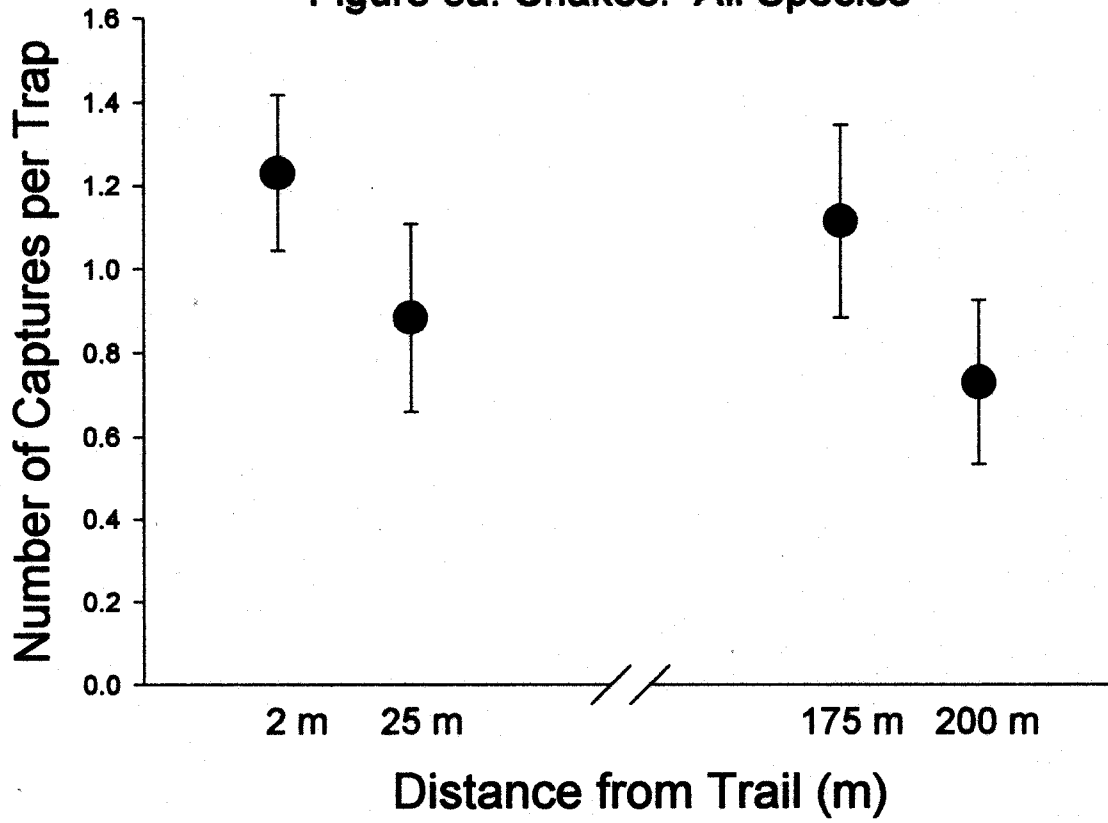

Figure 5b. Lizards: All Species

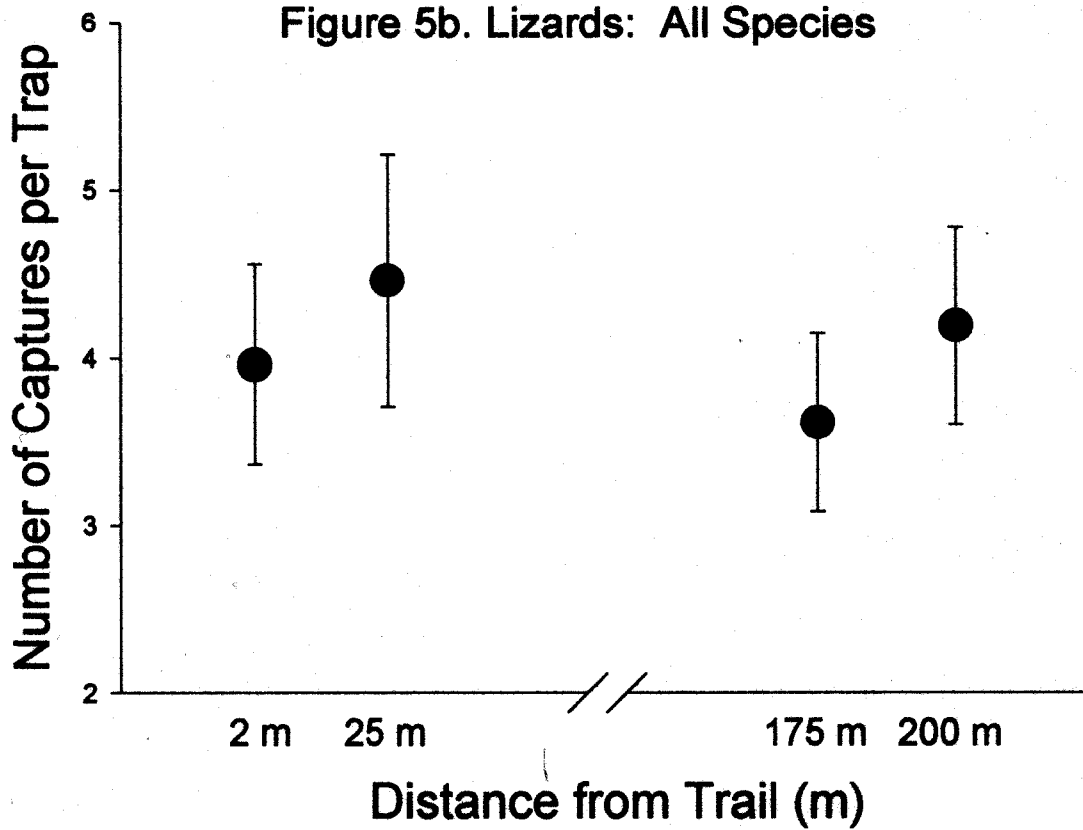

Figure 6a. Snakes: Sensitive Species

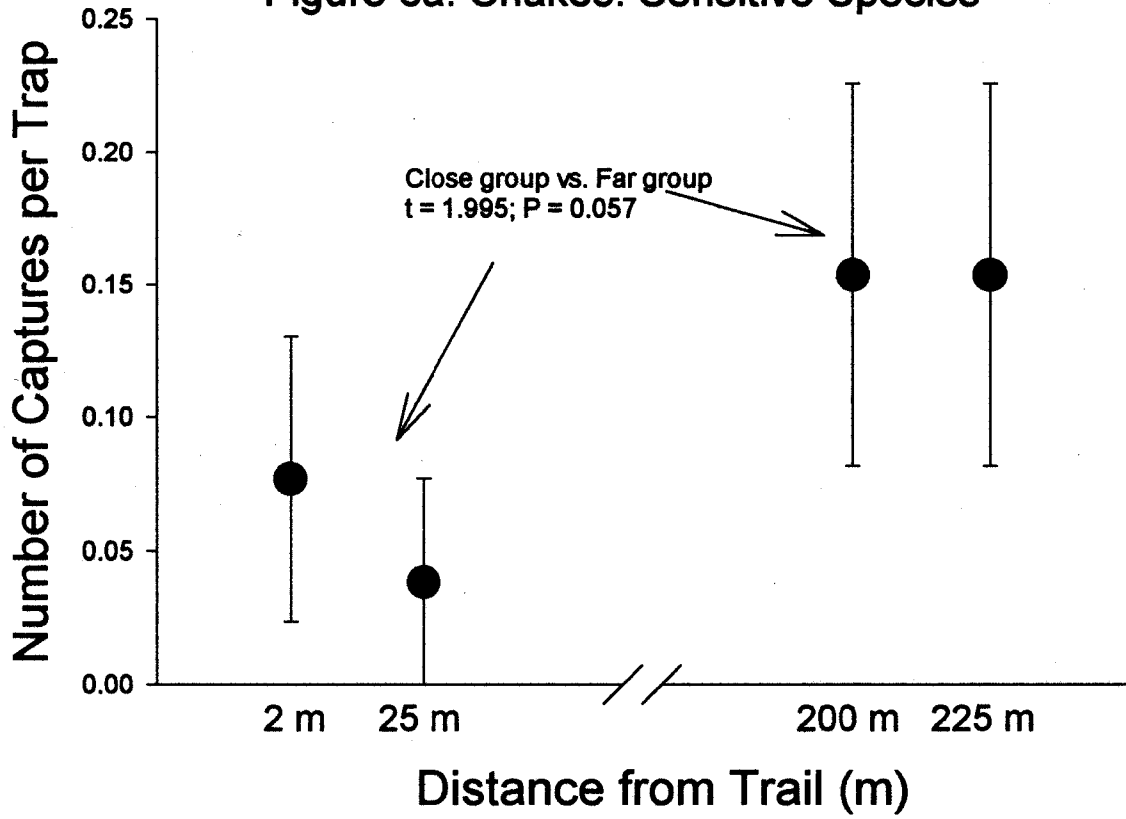
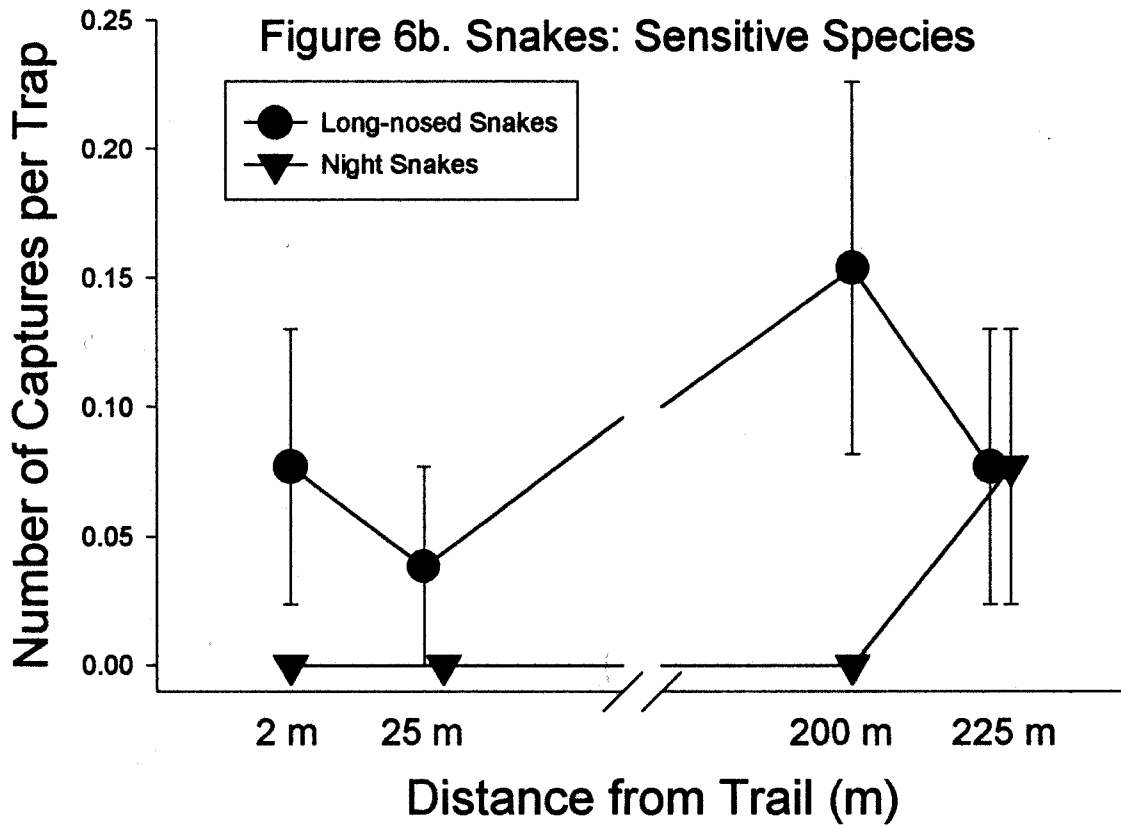
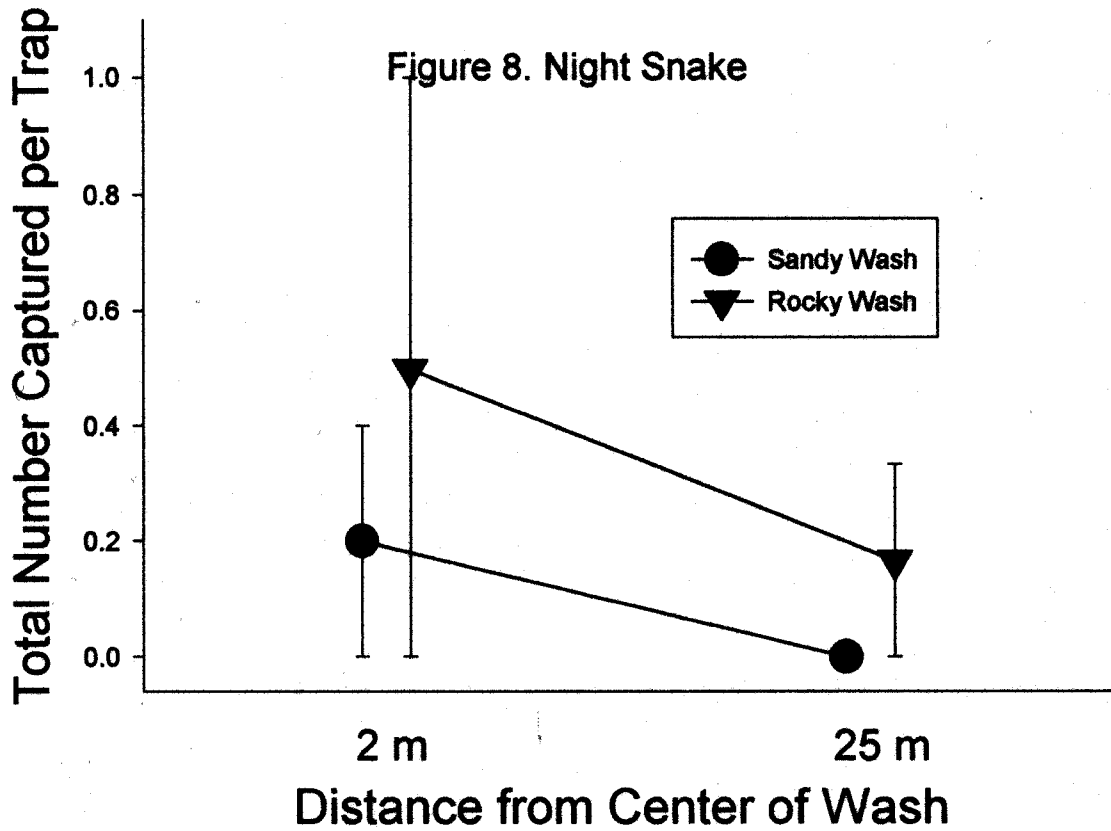
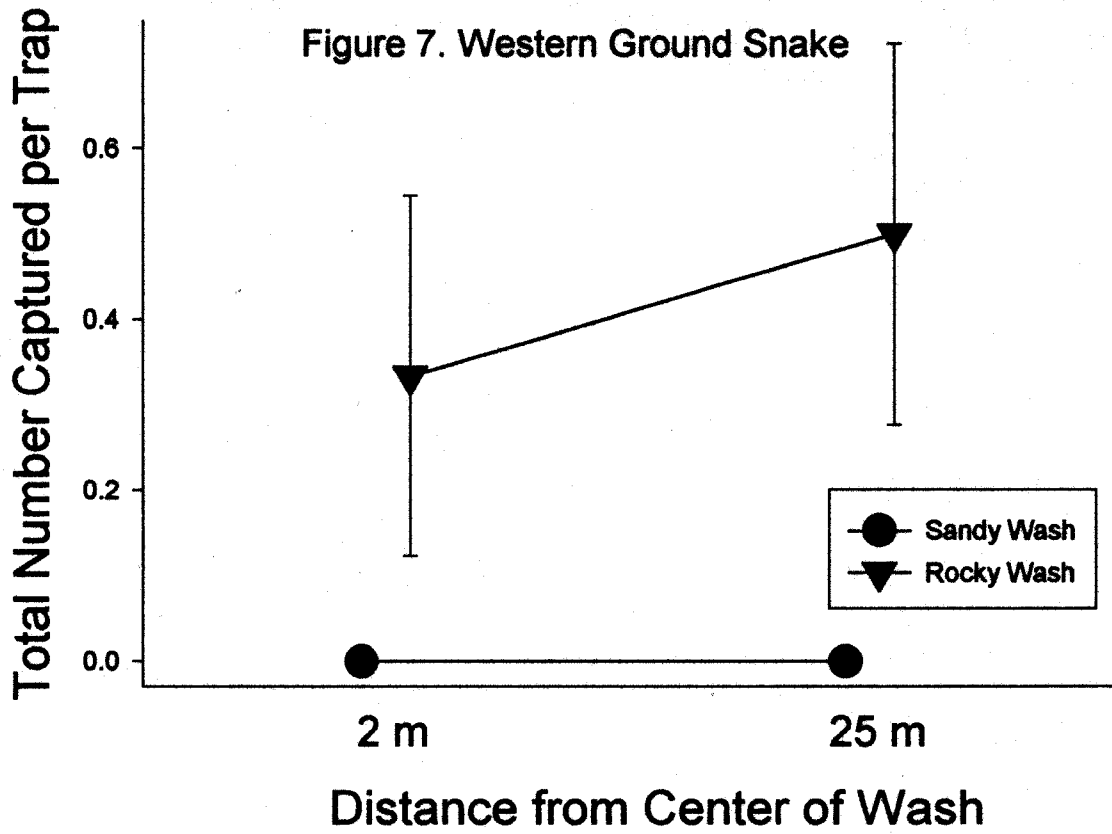

Figure 6b. Snakes: Sensitive Species





Appendix 1. Captures of snakes.						
Date	Time	Trap #	trapytype	Genus and species	Temp C	Weather
5/30/97	815	22B	***D***	<i>Pituophis catenifer</i>	22	sunny calm
5/30/97	948	02G	***C***	<i>Rhinocelhus lecontei</i>	27	sunny breezy
5/31/97	1209	00C	***A***	<i>Pituophis catenifer</i>	32	partly cloudy breezy
5/31/97	1227	00H	***B***	<i>Masticophis taeniatus</i>	34	partly cloudy light breeze
5/31/97	1244	01C	***A***	<i>Masticophis taeniatus</i>	36	partly cloudy light breeze
5/31/97	1304	02B	***B***	<i>Pituophis catenifer</i>	34	partly cloudy light breeze
5/31/97	1319	02E	***A***	<i>Pituophis catenifer</i>	34	partly cloudy light breeze
6/1/97	1029	00C	***A***	<i>Pituophis catenifer</i>	21	mostly cloudy breezy
6/1/97	1125	02B	***B***	<i>Masticophis taeniatus</i>	26	mostly cloudy breezy
6/1/97	1131	02C	***C***	<i>Pituophis catenifer</i>	27	mostly cloudy breezy
6/1/97	1140	02F	***B***	<i>Masticophis taeniatus</i>	27	mostly cloudy breezy
6/2/97	1714	00E	***C***	<i>Masticophis taeniatus</i>	31	clear calm
6/2/97	1817	02C	***C***	<i>Pituophis catenifer</i>	32	partly cloudy breezy
6/2/97	1840	02G	***C***	<i>Masticophis taeniatus</i>	29	partly cloudy breezy
6/2/97	1853	03C	***C***	<i>Masticophis taeniatus</i>	30	partly cloudy light breeze
6/7/97	1155	23B	***C***	<i>Masticophis taeniatus</i>	24	clear breezy
6/7/97	1444	2B	***B***	<i>Pituophis catenifer</i>	28	clear windy
6/8/97	1158	23F	***C***	<i>Masticophis taeniatus</i>	25	partly cloudy windy
6/8/97	1413	02C	***C***	<i>Masticophis taeniatus</i>	26	partly cloudy windy
6/9/97	1700	5D	***D***	<i>Masticophis taeniatus</i>	34	partly cloudy breezy
6/10/97	908	21B	***B***	<i>Pituophis catenifer</i>	19	clear light breeze
6/10/97	914	22B	***D***	<i>Masticophis taeniatus</i>	20	clear light breeze
6/11/97	919	00C	***A***	<i>Masticophis taeniatus</i>	26	clear light breeze
6/11/97	1118	02E	***A***	<i>Pituophis catenifer</i>	24	mostly cloudy light breeze
6/11/97	1147	03F	***A***	<i>Pituophis catenifer</i>	27	mostly cloudy light breeze
6/11/97	1147	03F	***A***	<i>Pituophis catenifer</i>	27	mostly cloudy light breeze
6/11/97	1158	13B	***D***	<i>Pituophis catenifer</i>	29	mostly cloudy light breeze
6/14/97	1428	6C	***C***	<i>Masticophis taeniatus</i>	29	partly cloudy breezy
6/14/97	1517	11A	***E***	<i>Sonora semiannulata</i>	28	partly cloudy breezy
6/14/97	1855	22I	***C***	<i>Rhinocelhus lecontei</i>	25	mostly cloudy light breeze
6/16/97	1157	23C	***D***	<i>Masticophis taeniatus</i>	32	partly cloudy windy
6/16/97	1242	22A	***C***	<i>Pituophis catenifer</i>	35	partly cloudy breezy
6/16/97	1305	6A	***A***	<i>Masticophis taeniatus</i>	28	partly cloudy breezy
6/16/97	1356	8B	***F***	<i>Sonora semiannulata</i>	33	partly cloudy breezy
6/16/97	1540	02A	***A***	<i>Masticophis taeniatus</i>	34	partly cloudy breezy
6/16/97	1600	02G	***C***	<i>Masticophis taeniatus</i>	35	partly cloudy calm
6/18/97	906	00F	***D***	<i>Pituophis catenifer</i>	21	clear breezy
6/18/97	914	4C	***C***	<i>Masticophis taeniatus</i>	22	partly cloudy breezy
6/19/97	836	11A	***E***	<i>Hypsiglena torquata</i>	22	clear breezy
6/19/97	1020	23I	***B***	<i>Masticophis taeniatus</i>	22	clear windy
6/19/97	1027	22C	***A***	<i>Masticophis taeniatus</i>	24	clear windy
6/19/97	1048	22B	***D***	<i>Masticophis taeniatus</i>	26	clear windy
6/20/97	1517	02F	***B***	<i>Pituophis catenifer</i>	27	clear breezy
6/20/97	1525	02H	***D***	<i>Masticophis taeniatus</i>	27	clear breezy
6/20/97	1543	13A	***C***	<i>Masticophis taeniatus</i>	28	clear breezy
6/21/97	1638	12B	***F***	<i>Sonora semiannulata</i>	34	partly cloudy breezy
6/22/97	1539	4D	***D***	<i>Hypsiglena torquata</i>	29	partly cloudy breezy
6/22/97	1546	4A	***A***	<i>Masticophis taeniatus</i>	30	partly cloudy breezy
6/22/97	1610	00D	***B***	<i>Masticophis taeniatus</i>	27	partly cloudy breezy
6/22/97	1659	1D	***D***	<i>Rhinocelhus lecontei</i>	30	partly cloudy breezy
6/23/97	1203	10B	***F***	<i>Sonora semiannulata</i>	26	partly cloudy breezy
6/23/97	1358	00B	***D***	<i>Pituophis catenifer</i>	20	mostly cloudy breezy
6/23/97	1404	23F	***C***	<i>Masticophis taeniatus</i>	20	mostly cloudy windy
6/23/97	1436	22J	***D***	<i>Masticophis taeniatus</i>	21	mostly cloudy windy
6/23/97	1443	22C	***A***	<i>Masticophis taeniatus</i>	23	mostly cloudy windy
6/23/97	1459	21B	***B***	<i>Masticophis taeniatus</i>	21	mostly cloudy breezy
6/23/97	1459	21B	***B***	<i>Pituophis catenifer</i>	21	mostly cloudy breezy
6/23/97	1507	22B	***D***	<i>Masticophis taeniatus</i>	21	mostly cloudy breezy
7/9/97	2005	14A	***A***	<i>Masticophis taeniatus</i>	25	mostly cloudy windy
7/10/97	1113	15B	***D***	<i>Hypsiglena torquata</i>	19	mostly cloudy windy
7/10/97	1132	15G	***A***	<i>Masticophis taeniatus</i>	18	mostly cloudy windy
7/10/97	1259	03D	***D***	<i>Pituophis catenifer</i>	21	partly cloudy windy

Date	Time	Trap #	traptype	Genus and species	Temp C	Weather
7/10/97	1306	03G	***B***	<i>Masticophis taeniatus</i>	21	partly cloudy windy
7/10/97	1350	01E	***C***	<i>Pituophis catenifer</i>	24	partly cloudy breezy
7/10/97	1413	1A	***A***	<i>Rhinocheilus lecontei</i>	25	partly cloudy breezy
7/10/97	1441	7A	***E***	<i>Pituophis catenifer</i>	29	partly cloudy breezy
7/10/97	1505	12A	***E***	<i>Sonora semiannulata</i>	25	partly cloudy breezy
7/10/97	1556	23H	***A***	<i>Masticophis taeniatus</i>	22	partly cloudy breezy
7/10/97	1615	22K	***A***	<i>Masticophis taeniatus</i>	23	partly cloudy breezy
7/10/97	1649	21A	***A***	<i>Masticophis taeniatus</i>	25	partly cloudy breezy
7/10/97	1656	22A	***C***	<i>Masticophis taeniatus</i>	25	partly cloudy breezy
7/10/97	1722	26B	***F***	<i>Masticophis taeniatus</i>	27	partly cloudy breezy
7/10/97	1739	29B	***F***	<i>Masticophis taeniatus</i>	27	partly cloudy breezy
7/10/97	1744	30B	***F***	<i>Pituophis catenifer</i>	28	partly cloudy breezy
7/10/97	1744	30B	***F***	<i>Pituophis catenifer</i>	28	partly cloudy breezy
7/10/97	1752	25A	***E***	<i>Pituophis catenifer</i>	26	partly cloudy breezy
7/11/97	1152	03F	***A***	<i>Masticophis taeniatus</i>	22	clear breezy
7/12/97	1245	01B	***D***	<i>Pituophis catenifer</i>	24	clear windy
7/12/97	1254	01F	***D***	<i>Masticophis taeniatus</i>	24	clear windy
7/12/97	1322	4A	***A***	<i>Masticophis taeniatus</i>	24	clear windy
7/13/97	1304	25A	***E***	<i>Masticophis taeniatus</i>	29	clear breezy
7/13/97	1333	21A	***A***	<i>Masticophis taeniatus</i>	32	clear breezy
7/13/97	1420	23F	***C***	<i>Masticophis taeniatus</i>	34	clear breezy
7/14/97	905	11A	***E***	<i>Hypsigena torquata</i>	27	clear calm
7/14/97	1028	02F	***B***	<i>Masticophis taeniatus</i>	29	clear breezy
7/14/97	1053	13A	***C***	<i>Rhinocheilus lecontei</i>	30	clear breezy
7/14/97	1102	03H	***A***	<i>Masticophis taeniatus</i>	30	clear breezy
7/15/97	1329	6A	***A***	<i>Masticophis taeniatus</i>	36	clear breezy
7/15/97	1335	6C	***C***	<i>Rhinocheilus lecontei</i>	37	clear breezy
7/15/97	1416	2C	***C***	<i>Pituophis catenifer</i>	34	clear windy
7/15/97	1627	11A	***E***	<i>Hypsigena torquata</i>	33	clear calm
7/15/97	1641	11B	***F***	<i>Hypsigena torquata</i>	37	clear calm
7/16/97	717	27A	***E***	<i>Hypsigena torquata</i>	21	clear breezy
7/16/97	750	22A	***C***	<i>Pituophis catenifer</i>	24	clear breezy
7/16/97	752	22B	***D***	<i>Rhinocheilus lecontei</i>	24	clear breezy
7/16/97	811	22H	***B***	<i>Pituophis catenifer</i>	25	clear windy
7/16/97	832	23B	***C***	<i>Pituophis catenifer</i>	25	clear windy
7/16/97	1016	14J	***B***	<i>Crotalus viridis</i>	29	clear breezy
7/16/97	1041	15I	***C***	<i>Pituophis catenifer</i>	31	clear breezy
7/16/97	1130	03H	***A***	<i>Masticophis taeniatus</i>	33	clear breezy
7/16/97	1138	03C	***C***	<i>Pituophis catenifer</i>	31	clear breezy
7/16/97	1259	12A	***E***	<i>Pituophis catenifer</i>	38	clear breezy
7/16/97	1410	4C	***C***	<i>Masticophis taeniatus</i>	34	clear breezy
7/17/97	822	14I	***A***	<i>Pituophis catenifer</i>	22	cloudy breezy
7/17/97	1236	23H	***A***	<i>Crotalus viridis</i>	26	cloudy breezy
7/19/97	950	14H	***D***	<i>Pituophis catenifer</i>	24	clear breezy
7/19/97	1132	4C	***C***	<i>Masticophis taeniatus</i>	28	partly cloudy light breeze
7/20/97	958	22K	***A***	<i>Pituophis catenifer</i>	29	clear calm
7/20/97	1011	22H	***B***	<i>Pituophis catenifer</i>	30	clear calm
7/21/97	1548	15L	***B***	<i>Masticophis taeniatus</i>	33	mostly cloudy windy
7/21/97	1706	12B	***F***	<i>Masticophis taeniatus</i>	33	clear breezy
7/22/97	739	23E	***B***	<i>Rhinocheilus lecontei</i>	24	clear breezy
7/22/97	759	22H	***B***	<i>Rhinocheilus lecontei</i>	24	clear breezy
7/22/97	1157	6B	***B***	<i>Pituophis catenifer</i>	39	clear breezy
7/23/97	845	14E	***A***	<i>Pituophis catenifer</i>	26	clear breezy
7/23/97	858	15A	***C***	<i>Pituophis catenifer</i>	25	clear breezy
7/23/97	950	2A	***A***	<i>Masticophis taeniatus</i>	27	clear breezy
7/23/97	950	2A	***A***	<i>Masticophis taeniatus</i>	27	clear breezy
7/23/97	959	00D	***B***	<i>Pituophis catenifer</i>	29	clear breezy
7/23/97	1112	23A	***B***	<i>Masticophis taeniatus</i>	30	clear windy
7/23/97	1228	12A	***E***	<i>Masticophis taeniatus</i>	38	clear breezy
7/24/97	821	6B	***B***	<i>Masticophis taeniatus</i>	30	clear breezy
7/24/97	1037	02F	***B***	<i>Pituophis catenifer</i>	30	clear breezy

Appendix 2. Captures of Lizards

Date	Time	Trap #	traptype	Genus and species	Temp C	Weather
5/29/97	1118	00H	***B***	<i>Cnemidophorus tigris</i>	26	cloudy breezy
5/29/97	1118	00H	***B***	<i>Cnemidophorus tigris</i>	26	cloudy breezy
5/29/97	1118	00H	***B***	<i>Cnemidophorus tigris</i>	26	cloudy breezy
5/29/97	1118	00H	***B***	<i>Cnemidophorus tigris</i>	26	cloudy breezy
5/29/97	1201	01F	***D***	<i>Cnemidophorus tigris</i>	24	cloudy light breeze
5/30/97	837	00D	***B***	<i>Cnemidophorus tigris</i>	21	sunny calm
5/30/97	851	00H	***B***	<i>Uta stansburiana</i>	24	sunny calm
5/30/97	857	01B	***D***	<i>Cnemidophorus tigris</i>	25	sunny breezy
5/31/97	1050	22C	***A***	<i>Cnemidophorus tigris</i>	22	partly cloudy breezy
5/31/97	1050	22C	***A***	<i>Cnemidophorus tigris</i>	22	partly cloudy breezy
5/31/97	1050	22C	***A***	<i>Gambelia wislizeni</i>	22	partly cloudy breezy
5/31/97	1100	22A	***C***	<i>Cnemidophorus tigris</i>	22	partly cloudy breezy
5/31/97	1105	22B	***D***	<i>Cnemidophorus tigris</i>	22	partly cloudy breezy
5/31/97	1218	00E	***C***	<i>Cnemidophorus tigris</i>	33	partly cloudy light breeze
5/31/97	1227	00H	***B***	<i>Cnemidophorus tigris</i>	34	partly cloudy light breeze
5/31/97	1233	01A	***C***	<i>Cnemidophorus tigris</i>	34	partly cloudy light breeze
5/31/97	1233	01A	***C***	<i>Cnemidophorus tigris</i>	34	partly cloudy light breeze
5/31/97	1311	02C	***C***	<i>Gambelia wislizeni</i>	33	partly cloudy calm
5/31/97	1322	02F	***B***	<i>Cnemidophorus tigris</i>	36	partly cloudy breezy
5/31/97	1324	02G	***C***	<i>Cnemidophorus tigris</i>	34	partly cloudy breezy
5/31/97	1324	02G	***C***	<i>Cnemidophorus tigris</i>	34	partly cloudy breezy
5/31/97	1340	03C	***C***	<i>Gambelia wislizeni</i>	34	partly cloudy calm
5/31/97	1402	13C	***C***	<i>Gambelia wislizeni</i>	36	partly cloudy breezy
5/31/97	1405	13D	***D***	<i>Uta stansburiana</i>	37	partly cloudy breezy
6/1/97	1032	00C	***A***	<i>Cnemidophorus tigris</i>	21	mostly cloudy breezy
6/1/97	1041	00F	***D***	<i>Cnemidophorus tigris</i>	24	mostly cloudy breezy
6/1/97	1051	00G	***A***	<i>Cnemidophorus tigris</i>	22	mostly cloudy breezy
6/1/97	1044	00E	***C***	<i>Cnemidophorus tigris</i>	23	mostly cloudy breezy
6/1/97	1059	01B	***D***	<i>Uta stansburiana</i>	23	mostly cloudy breezy
6/1/97	1224	13C	***C***	<i>Cnemidophorus tigris</i>	29	partly cloudy breezy
6/2/97	1619	21B	***B***	<i>Cnemidophorus tigris</i>	28	clear calm
6/2/97	1713	00E	***C***	<i>Phrynosoma platyrhinos</i>	31	clear calm
6/2/97	1715	00E	***C***	<i>Cnemidophorus tigris</i>	31	clear calm
6/2/97	1726	00H	***B***	<i>Cnemidophorus tigris</i>	33	partly cloudy breezy
6/2/97	1726	00H	***B***	<i>Cnemidophorus tigris</i>	33	partly cloudy breezy
6/2/97	1733	01B	***D***	<i>Gambelia wislizeni</i>	33	partly cloudy breezy
6/2/97	1809	02A	***A***	<i>Phrynosoma platyrhinos</i>	32	partly cloudy breezy
6/2/97	1809	02A	***A***	<i>Phrynosoma platyrhinos</i>	32	partly cloudy breezy
6/2/97	1818	02C	***C***	<i>Cnemidophorus tigris</i>	32	partly cloudy breezy
6/2/97	1833	02F	***B***	<i>Cnemidophorus tigris</i>	31	partly cloudy breezy
6/2/97	1833	02F	***B***	<i>Cnemidophorus tigris</i>	31	partly cloudy breezy
6/2/97	1840	02G	***C***	<i>Uta stansburiana</i>	29	partly cloudy breezy
6/2/97	1840	02G	***C***	<i>Cnemidophorus tigris</i>	29	partly cloudy breezy
6/2/97	1854	03C	***C***	<i>Cnemidophorus tigris</i>	30	partly cloudy light breeze
6/2/97	1857	03D	***D***	<i>Cnemidophorus tigris</i>	30	high clouds light breeze
6/2/97	1905	03F	***A***	<i>Cnemidophorus tigris</i>	29	high clouds light breeze
6/2/97	1919	03I	***B***	<i>Cnemidophorus tigris</i>	28	high clouds light breeze
6/2/97	1919	03I	***B***	<i>Cnemidophorus tigris</i>	28	high clouds light breeze
6/7/97	1026	6B	***B***	<i>Cnemidophorus tigris</i>	28	clear breezy
6/7/97	1032	6D	***D***	<i>Uta stansburiana</i>	26	clear breezy
6/7/97	1036	00F	***D***	<i>Cnemidophorus tigris</i>	26	clear breezy
6/7/97	1036	00F	***D***	<i>Cnemidophorus tigris</i>	26	clear breezy
6/7/97	1038	00E	***C***	<i>Cnemidophorus tigris</i>	26	clear breezy
6/7/97	1041	4C	***C***	<i>Cnemidophorus tigris</i>	26	clear breezy
6/7/97	1044	4D	***D***	<i>Uta stansburiana</i>	25	clear breezy
6/7/97	1051	4A	***A***	<i>Cnemidophorus tigris</i>	25	clear breezy
6/7/97	1101	5C	***C***	<i>Cnemidophorus tigris</i>	27	clear light breeze
6/7/97	1104	5D	***D***	<i>Uta stansburiana</i>	27	clear light breeze
6/7/97	1126	23H	***A***	<i>Cnemidophorus tigris</i>	26	clear breezy
6/7/97	1128	23I	***B***	<i>Cnemidophorus tigris</i>	26	clear breezy
6/7/97	1150	23A	***B***	<i>Cnemidophorus tigris</i>	26	clear breezy
6/7/97	1204	22H	***B***	<i>Cnemidophorus tigris</i>	25	clear breezy

Date	Time	Trap #	traptype	Genus and species	Temp C	Weather
6/7/97	1231	22A	***C***	<i>Cnemidophorus tigris</i>	28	clear breezy
6/7/97	1233	22B	***D***	<i>Cnemidophorus tigris</i>	26	clear breezy
6/7/97	1253	00C	***A***	<i>Cnemidophorus tigris</i>	26	clear breezy
6/7/97	1258	00G	***A***	<i>Cnemidophorus tigris</i>	26	clear breezy
6/7/97	1300	00H	***B***	<i>Cnemidophorus tigris</i>	26	clear breezy
6/7/97	1322	01F	***D***	<i>Uta stansburiana</i>	28	clear breezy
6/7/97	1334	02A	***A***	<i>Cnemidophorus tigris</i>	27	clear breezy
6/7/97	1346	3C	***C***	<i>Cnemidophorus tigris</i>	28	clear breezy
6/7/97	1346	3C	***C***	<i>Cnemidophorus tigris</i>	28	clear breezy
6/7/97	1349	3D	***D***	<i>Cnemidophorus tigris</i>	28	clear breezy
6/7/97	1355	02F	***B***	<i>Cnemidophorus tigris</i>	29	clear windy
6/7/97	1400	02G	***C***	<i>Cnemidophorus tigris</i>	29	clear breezy
6/7/97	1402	02H	***D***	<i>Cnemidophorus tigris</i>	27	clear breezy
6/7/97	1402	02H	***D***	<i>Cnemidophorus tigris</i>	27	clear breezy
6/7/97	1402	02H	***D***	<i>Cnemidophorus tigris</i>	27	clear breezy
6/7/97	1429	03I	***B***	<i>Cnemidophorus tigris</i>	30	clear windy
6/7/97	1438	3B	***B***	<i>Cnemidophorus tigris</i>	28	clear windy
6/7/97	1445	3B	***B***	<i>Cnemidophorus tigris</i>	28	clear breezy
6/8/97	1148	00A	***C***	<i>Cnemidophorus tigris</i>	23	partly cloudy windy
6/8/97	1154	23D	***A***	<i>Cnemidophorus tigris</i>	23	partly cloudy windy
6/8/97	1205	22K	***A***	<i>Cnemidophorus tigris</i>	25	partly cloudy windy
6/8/97	1205	22K	***A***	<i>Cnemidophorus tigris</i>	25	partly cloudy windy
6/8/97	1209	23B	***C***	<i>Cnemidophorus tigris</i>	24	partly cloudy windy
6/8/97	1214	22G	***A***	<i>Cnemidophorus tigris</i>	24	partly cloudy windy
6/8/97	1238	22A	***C***	<i>Cnemidophorus tigris</i>	24	partly cloudy windy
6/8/97	1240	22A	***C***	<i>Gambelia wislizenii</i>	25	partly cloudy windy
6/8/97	1242	22B	***D***	<i>Cnemidophorus tigris</i>	25	partly cloudy windy
6/8/97	1301	6A	***A***	<i>Cnemidophorus tigris</i>	26	partly cloudy windy
6/8/97	1301	6A	***A***	<i>Cnemidophorus tigris</i>	26	partly cloudy windy
6/8/97	1303	6A	***A***	<i>Uta stansburiana</i>	26	partly cloudy windy
6/8/97	1310	00F	***D***	<i>Cnemidophorus tigris</i>	25	partly cloudy windy
6/8/97	1310	00F	***D***	<i>Cnemidophorus tigris</i>	25	partly cloudy windy
6/8/97	1311	00E	***C***	<i>Cnemidophorus tigris</i>	25	partly cloudy windy
6/8/97	1316	4B	***B***	<i>Cnemidophorus tigris</i>	25	partly cloudy windy
6/8/97	1316	4B	***B***	<i>Cnemidophorus tigris</i>	25	partly cloudy windy
6/8/97	1317	4B	***B***	<i>Cnemidophorus tigris</i>	25	partly cloudy windy
6/8/97	1317	4B	***B***	<i>Cnemidophorus tigris</i>	25	partly cloudy windy
6/8/97	1321	5A	***A***	<i>Cnemidophorus tigris</i>	26	partly cloudy windy
6/8/97	1321	5A	***A***	<i>Cnemidophorus tigris</i>	26	partly cloudy windy
6/8/97	1321	5A	***A***	<i>Cnemidophorus tigris</i>	26	partly cloudy windy
6/8/97	1335	03H	***A***	<i>Cnemidophorus tigris</i>	27	partly cloudy windy
6/8/97	1401	02G	***C***	<i>Cnemidophorus tigris</i>	26	partly cloudy windy
6/8/97	1413	02C	***C***	<i>Cnemidophorus tigris</i>	26	partly cloudy windy
6/8/97	1422	00D	***B***	<i>Cnemidophorus tigris</i>	27	partly cloudy windy
6/8/97	1432	01C	***A***	<i>Cnemidophorus tigris</i>	26	partly cloudy windy
6/8/97	1437	01F	***D***	<i>Cnemidophorus tigris</i>	27	partly cloudy windy
6/8/97	1516	3A	***A***	<i>Cnemidophorus tigris</i>	27	partly cloudy windy
6/8/97	1518	3B	***B***	<i>Cnemidophorus tigris</i>	27	partly cloudy windy
6/8/97	1518	3B	***B***	<i>Cnemidophorus tigris</i>	27	partly cloudy windy
6/8/97	1518	3B	***B***	<i>Cnemidophorus tigris</i>	27	partly cloudy windy
6/8/97	1525	2D	***D***	<i>Cnemidophorus tigris</i>	28	partly cloudy windy
6/9/97	1519	6A	***A***	<i>Cnemidophorus tigris</i>	30	mostly cloudy breezy
6/9/97	1519	6A	***A***	<i>Cnemidophorus tigris</i>	30	mostly cloudy breezy
6/9/97	1654	5B	***B***	<i>Cnemidophorus tigris</i>	35	partly cloudy breezy
6/9/97	1742	3B	***B***	<i>Cnemidophorus tigris</i>	31	partly cloudy windy
6/10/97	833	22G	***A***	<i>Cnemidophorus tigris</i>	18	clear breezy
6/10/97	858	22E	***C***	<i>Cnemidophorus tigris</i>	19	clear light breeze
6/11/97	835	6C	***C***	<i>Cnemidophorus tigris</i>	23	clear light breeze
6/11/97	843	00F	***D***	<i>Cnemidophorus tigris</i>	23	clear light breeze
6/11/97	855	4B	***B***	<i>Cnemidophorus tigris</i>	24	clear light breeze
6/11/97	855	4B	***B***	<i>Cnemidophorus tigris</i>	24	clear light breeze
6/11/97	855	4B	***B***	<i>Cnemidophorus tigris</i>	24	clear light breeze
6/11/97	931	00B	***D***	<i>Cnemidophorus tigris</i>	25	clear light breeze

Date	Time	Trap #	traptype	Genus and species	Temp C	Weather
6/11/97	936	01C	***A***	<i>Cnemidophorus tigris</i>	26	clear light breeze
6/11/97	950	01F	***D***	<i>Cnemidophorus tigris</i>	28	clear light breeze
6/11/97	950	01F	***D***	<i>Cnemidophorus tigris</i>	28	clear light breeze
6/11/97	1026	2B	***B***	<i>Cnemidophorus tigris</i>	24	partly cloudy light breeze
6/11/97	1034	3A	***A***	<i>Cnemidophorus tigris</i>	24	partly cloudy light breeze
6/11/97	1038	02D	***D***	<i>Cnemidophorus tigris</i>	24	partly cloudy light breeze
6/11/97	1038	02D	***D***	<i>Cnemidophorus tigris</i>	24	partly cloudy light breeze
6/11/97	1112	02B	***B***	<i>Cnemidophorus tigris</i>	24	mostly cloudy light breeze
6/11/97	1112	02B	***B***	<i>Cnemidophorus tigris</i>	24	mostly cloudy light breeze
6/11/97	1112	02B	***B***	<i>Cnemidophorus tigris</i>	24	mostly cloudy light breeze
6/11/97	1120	02F	***B***	<i>Cnemidophorus tigris</i>	24	mostly cloudy light breeze
6/11/97	1126	02G	***C***	<i>Cnemidophorus tigris</i>	26	mostly cloudy light breeze
6/11/97	1203	13D	***D***	<i>Uta stansburiana</i>	30	mostly cloudy light breeze
6/11/97	1208	03I	***B***	<i>Cnemidophorus tigris</i>	30	mostly cloudy light breeze
6/3/97	942	21A	***A***	<i>Cnemidophorus tigris</i>	22	cloudy light breeze
6/3/97	1034	00F	***D***	<i>Cnemidophorus tigris</i>	23	cloudy light breeze
6/5/97	834	21A	***A***	<i>Cnemidophorus tigris</i>	18	cloudy wind
6/5/97	914	00F	***D***	<i>Cnemidophorus tigris</i>	18	cloudy wind
6/5/97	914	00F	***D***	<i>Cnemidophorus tigris</i>	18	cloudy wind
6/5/97	930	00C	***A***	<i>Cnemidophorus tigris</i>	18	cloudy wind
6/5/97	939	00H	***B***	<i>Cnemidophorus tigris</i>	18	cloudy wind
6/5/97	948	01C	***A***	<i>Cnemidophorus tigris</i>	17	cloudy wind
6/5/97	1031	03D	***D***	<i>Cnemidophorus tigris</i>	19	partly cloudy windy
6/5/97	1031	03D	***D***	<i>Cnemidophorus tigris</i>	19	partly cloudy windy
6/6/97	819	8A	***A***	<i>Uta stansburiana</i>	18	clear breezy
6/6/97	905	3B	***B***	<i>Cnemidophorus tigris</i>	19	clear breezy
6/6/97	905	3B	***B***	<i>Cnemidophorus tigris</i>	19	clear breezy
6/14/97	1432	00E	***C***	<i>Cnemidophorus tigris</i>	30	partly cloudy breezy
6/14/97	1440	4A	***A***	<i>Cnemidophorus tigris</i>	30	partly cloudy breezy
6/14/97	1440	4A	***A***	<i>Cnemidophorus tigris</i>	30	partly cloudy breezy
6/14/97	1442	5A	***A***	<i>Cnemidophorus tigris</i>	26	partly cloudy breezy
6/14/97	1444	5B	***B***	<i>Cnemidophorus tigris</i>	27	partly cloudy breezy
6/14/97	1447	5C	***C***	<i>Cnemidophorus tigris</i>	27	partly cloudy breezy
6/14/97	1449	5D	***D***	<i>Cnemidophorus tigris</i>	27	partly cloudy breezy
6/14/97	1512	10A	***E***	<i>Cnemidophorus tigris</i>	28	partly cloudy breezy
6/14/97	1517	11A	***E***	<i>Cnemidophorus tigris</i>	28	partly cloudy breezy
6/14/97	1559	00D	***B***	<i>Cnemidophorus tigris</i>	29	partly cloudy light breeze
6/14/97	1604	00G	***A***	<i>Cnemidophorus tigris</i>	31	partly cloudy light breeze
6/14/97	1608	01A	***C***	<i>Cnemidophorus tigris</i>	32	partly cloudy calm
6/14/97	1612	01B	***D***	<i>Cnemidophorus tigris</i>	32	partly cloudy calm
6/14/97	1617	01C	***A***	<i>Cnemidophorus tigris</i>	29	partly cloudy breezy
6/14/97	1617	01C	***A***	<i>Cnemidophorus tigris</i>	29	partly cloudy breezy
6/14/97	1635	02D	***D***	<i>Cnemidophorus tigris</i>	29	partly cloudy breezy
6/14/97	1638	3C	***C***	<i>Cnemidophorus tigris</i>	29	partly cloudy breezy
6/14/97	1642	3D	***D***	<i>Cnemidophorus tigris</i>	30	partly cloudy breezy
6/14/97	1642	3D	***D***	<i>Cnemidophorus tigris</i>	30	partly cloudy breezy
6/14/97	1642	3D	***D***	<i>Cnemidophorus tigris</i>	30	partly cloudy breezy
6/14/97	1726	2D	***D***	<i>Cnemidophorus tigris</i>	29	partly cloudy calm
6/14/97	1817	00A	***C***	<i>Cnemidophorus tigris</i>	26	partly cloudy breezy
6/14/97	1819	00B	***D***	<i>Cnemidophorus tigris</i>	27	partly cloudy breezy
6/14/97	1819	00B	***D***	<i>Cnemidophorus tigris</i>	27	partly cloudy breezy
6/14/97	1828	23G	***D***	<i>Cnemidophorus tigris</i>	26	mostly cloudy light breeze
6/14/97	1838	23B	***C***	<i>Cnemidophorus tigris</i>	26	mostly cloudy light breeze
6/14/97	1841	23C	***D***	<i>Cnemidophorus tigris</i>	26	mostly cloudy light breeze
6/14/97	1851	22J	***D***	<i>Cnemidophorus tigris</i>	26	mostly cloudy light breeze
6/14/97	1904	22F	***D***	<i>Cnemidophorus tigris</i>	27	mostly cloudy calm
6/14/97	1915	22A	***C***	<i>Cnemidophorus tigris</i>	27	mostly cloudy calm
6/14/97	1919	22B	***D***	<i>Uta stansburiana</i>	27	mostly cloudy calm
6/16/97	1210	22J	***D***	<i>Cnemidophorus tigris</i>	33	partly cloudy windy
6/16/97	1210	22J	***D***	<i>Cnemidophorus tigris</i>	33	partly cloudy breezy
6/16/97	1214	22I	***C***	<i>Cnemidophorus tigris</i>	34	partly cloudy breezy
6/16/97	1219	22C	***A***	<i>Cnemidophorus tigris</i>	35	partly cloudy breezy

Date	Time	Trap #	traptype	Genus and species	Temp C	Weather
6/16/97	1224	22F	***D***	<i>Cnemidophorus tigris</i>	34	partly cloudy breezy
6/16/97	1224	22F	***D***	<i>Cnemidophorus tigris</i>	34	partly cloudy breezy
6/16/97	1233	21A	***A***	<i>Cnemidophorus tigris</i>	33	partly cloudy breezy
6/16/97	1233	21A	***A***	<i>Cnemidophorus tigris</i>	33	partly cloudy breezy
6/16/97	1233	21A	***A***	<i>Cnemidophorus tigris</i>	33	partly cloudy breezy
6/16/97	1233	21A	***A***	<i>Gambella wislizeni</i>	33	partly cloudy breezy
6/16/97	1244	22B	***D***	<i>Cnemidophorus tigris</i>	35	partly cloudy breezy
6/16/97	1310	6C	***C***	<i>Cnemidophorus tigris</i>	28	partly cloudy breezy
6/16/97	1322	4B	***B***	<i>Cnemidophorus tigris</i>	28	partly cloudy breezy
6/16/97	1328	5B	***B***	<i>Cnemidophorus tigris</i>	31	partly cloudy breezy
6/16/97	1333	5D	***D***	<i>Cnemidophorus tigris</i>	31	partly cloudy breezy
6/16/97	1333	5D	***D***	<i>Cnemidophorus tigris</i>	31	partly cloudy breezy
6/16/97	1352	7A	***E***	<i>Cnemidophorus tigris</i>	32	partly cloudy breezy
6/16/97	1353	7B	***F***	<i>Cnemidophorus tigris</i>	32	partly cloudy breezy
6/16/97	1353	7B	***F***	<i>Cnemidophorus tigris</i>	32	partly cloudy breezy
6/16/97	1353	7B	***F***	<i>Cnemidophorus tigris</i>	32	partly cloudy breezy
6/16/97	1413	10B	***F***	<i>Cnemidophorus tigris</i>	35	partly cloudy breezy
6/16/97	1418	11A	***E***	<i>Cnemidophorus tigris</i>	36	partly cloudy breezy
6/16/97	1426	12A	***E***	<i>Cnemidophorus tigris</i>	33	partly cloudy breezy
6/16/97	1427	12A	***E***	<i>Uta stansburiana</i>	33	partly cloudy breezy
6/16/97	1505	00C	***A***	<i>Cnemidophorus tigris</i>	34	partly cloudy breezy
6/16/97	1512	00G	***A***	<i>Phrynosoma platyrhinos</i>	33	partly cloudy light breeze
6/16/97	1512	00G	***A***	<i>Uta stansburiana</i>	33	partly cloudy light breeze
6/16/97	1518	01B	***D***	<i>Cnemidophorus tigris</i>	33	partly cloudy light breeze
6/16/97	1528	01E	***C***	<i>Cnemidophorus tigris</i>	33	partly cloudy light breeze
6/16/97	1528	01E	***C***	<i>Cnemidophorus tigris</i>	33	partly cloudy light breeze
6/16/97	1528	01E	***C***	<i>Cnemidophorus tigris</i>	33	partly cloudy light breeze
6/16/97	1530	01F	***D***	<i>Cnemidophorus tigris</i>	33	partly cloudy breezy
6/16/97	1546	02C	***C***	<i>Cnemidophorus tigris</i>	34	partly cloudy breezy
6/16/97	1546	02C	***C***	<i>Cnemidophorus tigris</i>	34	partly cloudy breezy
6/16/97	1634	02H	***D***	<i>Gambella wislizeni</i>	35	partly cloudy breezy
6/16/97	1705	3B	***B***	<i>Cnemidophorus tigris</i>	34	partly cloudy breezy
6/16/97	1707	2A	***A***	<i>Cnemidophorus tigris</i>	34	partly cloudy breezy
6/16/97	1723	2D	***D***	<i>Cnemidophorus tigris</i>	36	partly cloudy breezy
6/16/97	1723	2D	***D***	<i>Cnemidophorus tigris</i>	36	partly cloudy breezy
6/16/97	1728	1A	***A***	<i>Cnemidophorus tigris</i>	36	partly cloudy breezy
6/17/97	1148	2A	***A***	<i>Cnemidophorus tigris</i>	31	clear breezy
6/17/97	1303	7B	***F***	<i>Cnemidophorus tigris</i>	36	mostly cloudy breezy
6/17/97	1306	7B	***F***	<i>Cnemidophorus tigris</i>	35	mostly cloudy breezy
6/17/97	1702	10A	***E***	<i>Cnemidophorus tigris</i>	35	mostly cloudy breezy
6/18/97	903	6D	***D***	<i>Cnemidophorus tigris</i>	21	clear breezy
6/18/97	907	00F	***D***	<i>Cnemidophorus tigris</i>	21	clear breezy
6/18/97	910	00E	***C***	<i>Cnemidophorus tigris</i>	22	clear breezy
6/18/97	933	3A	***A***	<i>Cnemidophorus tigris</i>	20	partly cloudy windy
6/18/97	938	3B	***B***	<i>Cnemidophorus tigris</i>	21	partly cloudy windy
6/18/97	946	2D	***D***	<i>Phrynosoma platyrhinos</i>	22	partly cloudy windy
6/18/97	958	1D	***D***	<i>Gambella wislizeni</i>	23	partly cloudy windy
6/18/97	1030	01B	***D***	<i>Phrynosoma platyrhinos</i>	24	partly cloudy windy
6/18/97	1052	02C	***C***	<i>Cnemidophorus tigris</i>	24	partly cloudy windy
6/18/97	1109	02H	***D***	<i>Cnemidophorus tigris</i>	27	partly cloudy breezy
6/18/97	1135	13D	***D***	<i>Cnemidophorus tigris</i>	28	partly cloudy breezy
6/18/97	1141	03H	***A***	<i>Uta stansburiana</i>	27	partly cloudy breezy
6/19/97	821	8B	***F***	<i>Cnemidophorus tigris</i>	22	clear light breeze
6/19/97	841	12B	***F***	<i>Cnemidophorus tigris</i>	21	clear breezy
6/19/97	845	12A	***E***	<i>Uta stansburiana</i>	22	clear breezy
6/19/97	845	12A	***E***	<i>Uta stansburiana</i>	22	clear breezy
6/19/97	937	00A	***C***	<i>Cnemidophorus tigris</i>	20	clear windy
6/19/97	947	23D	***A***	<i>Cnemidophorus tigris</i>	21	clear windy
6/19/97	954	23G	***D***	<i>Cnemidophorus tigris</i>	22	clear windy
6/19/97	1001	23A	***B***	<i>Cnemidophorus tigris</i>	22	clear windy
6/19/97	1010	22G	***A***	<i>Cnemidophorus tigris</i>	23	clear windy
6/19/97	1013	22H	***B***	<i>Cnemidophorus tigris</i>	23	clear windy
6/19/97	1029	22D	***B***	<i>Cnemidophorus tigris</i>	24	clear windy

Date	Time	Trap #	trapytype	Genus and species	Temp C	Weather
6/19/97	1046	22A	***C***	<i>Cnemidophorus tigris</i>	25	clear windy
6/20/97	1336	6A	***A***	<i>Cnemidophorus tigris</i>	24	clear calm
6/20/97	1338	6B	***B***	<i>Cnemidophorus tigris</i>	25	clear calm
6/20/97	1338	6B	***B***	<i>Cnemidophorus tigris</i>	25	clear calm
6/20/97	1341	6D	***D***	<i>Cnemidophorus tigris</i>	25	clear calm
6/20/97	1348	4D	***D***	<i>Cnemidophorus tigris</i>	25	clear calm
6/20/97	1348	4D	***D***	<i>Cnemidophorus tigris</i>	25	clear calm
6/20/97	1350	4D	***D***	<i>Gambella wislizeni</i>	25	clear calm
6/20/97	1356	5A	***A***	<i>Cnemidophorus tigris</i>	25	clear calm
6/20/97	1402	5D	***D***	<i>Uta stansburiana</i>	25	clear calm
6/20/97	1422	00G	***A***	<i>Cnemidophorus tigris</i>	25	clear calm
6/20/97	1422	00G	***A***	<i>Cnemidophorus tigris</i>	25	clear calm
6/20/97	1425	00H	***B***	<i>Cnemidophorus tigris</i>	25	clear breezy
6/20/97	1439	01D	***B***	<i>Cnemidophorus tigris</i>	27	clear windy
6/20/97	1439	01D	***B***	<i>Cnemidophorus tigris</i>	27	clear windy
6/20/97	1439	01D	***B***	<i>Cnemidophorus tigris</i>	27	clear windy
6/20/97	1442	01E	***C***	<i>Cnemidophorus tigris</i>	27	clear windy
6/20/97	1444	01F	***D***	<i>Cnemidophorus tigris</i>	27	clear windy
6/20/97	1457	02A	***A***	<i>Cnemidophorus tigris</i>	26	clear windy
6/20/97	1459	02B	***B***	<i>Cnemidophorus tigris</i>	27	clear breezy
6/20/97	1538	03G	***B***	<i>Cnemidophorus tigris</i>	29	clear breezy
6/20/97	1549	13B	***D***	<i>Cnemidophorus tigris</i>	28	clear breezy
6/20/97	1548	13C	***C***	<i>Cnemidophorus tigris</i>	29	clear breezy
6/20/97	1548	13C	***C***	<i>Cnemidophorus tigris</i>	29	clear breezy
6/20/97	1548	13C	***C***	<i>Cnemidophorus tigris</i>	29	clear breezy
6/20/97	1553	03I	***B***	<i>Cnemidophorus tigris</i>	29	clear breezy
6/21/97	1635	11B	***F***	<i>Cnemidophorus tigris</i>	35	partly cloudy breezy
6/21/97	1645	12A	***E***	<i>Uta stansburiana</i>	32	partly cloudy breezy
6/22/97	1529	6D	***D***	<i>Cnemidophorus tigris</i>	28	partly cloudy breezy
6/22/97	1546	4A	***A***	<i>Cnemidophorus tigris</i>	30	partly cloudy breezy
6/22/97	1549	5A	***A***	<i>Cnemidophorus tigris</i>	30	partly cloudy breezy
6/22/97	1616	00G	***A***	<i>Cnemidophorus tigris</i>	26	partly cloudy breezy
6/22/97	1618	00H	***B***	<i>Cnemidophorus tigris</i>	26	partly cloudy breezy
6/22/97	1623	01A	***C***	<i>Uta stansburiana</i>	27	partly cloudy breezy
6/22/97	1623	01A	***C***	<i>Gambella wislizeni</i>	27	partly cloudy breezy
6/22/97	1626	01B	***D***	<i>Cnemidophorus tigris</i>	27	partly cloudy breezy
6/22/97	1634	01D	***B***	<i>Cnemidophorus tigris</i>	26	partly cloudy breezy
6/22/97	1634	01D	***B***	<i>Cnemidophorus tigris</i>	26	partly cloudy breezy
6/22/97	1634	01D	***B***	<i>Cnemidophorus tigris</i>	26	partly cloudy breezy
6/22/97	1653	1A	***A***	<i>Cnemidophorus tigris</i>	30	partly cloudy breezy
6/22/97	1707	02C	***C***	<i>Cnemidophorus tigris</i>	28	partly cloudy breezy
6/22/97	1716	3A	***A***	<i>Cnemidophorus tigris</i>	27	partly cloudy breezy
6/22/97	1716	3A	***A***	<i>Cnemidophorus tigris</i>	27	partly cloudy breezy
6/22/97	1718	3B	***B***	<i>Cnemidophorus tigris</i>	27	partly cloudy breezy
6/22/97	1718	3B	***B***	<i>Cnemidophorus tigris</i>	27	partly cloudy breezy
6/22/97	1721	2A	***A***	<i>Cnemidophorus tigris</i>	27	partly cloudy breezy
6/22/97	1728	2D	***D***	<i>Uta stansburiana</i>	25	partly cloudy breezy
6/22/97	1749	02F	***B***	<i>Cnemidophorus tigris</i>	26	partly cloudy breezy
6/22/97	1756	02H	***D***	<i>Gambella wislizeni</i>	27	partly cloudy breezy
6/22/97	1805	03C	***C***	<i>Cnemidophorus tigris</i>	29	partly cloudy breezy
6/22/97	1806	03D	***D***	<i>Cnemidophorus tigris</i>	30	partly cloudy breezy
6/22/97	1806	03D	***D***	<i>Cnemidophorus tigris</i>	30	partly cloudy breezy
6/22/97	1825	03I	***B***	<i>Cnemidophorus tigris</i>	29	partly cloudy breezy
6/22/97	1827	03H	***A***	<i>Uta stansburiana</i>	29	partly cloudy breezy
6/23/97	1207	10A	***E***	<i>Cnemidophorus tigris</i>	26	partly cloudy breezy
6/23/97	1231	11B	***F***	<i>Cnemidophorus tigris</i>	25	partly cloudy breezy
6/23/97	1231	11B	***F***	<i>Cnemidophorus tigris</i>	25	partly cloudy breezy
6/23/97	1355	00A	***C***	<i>Cnemidophorus tigris</i>	20	mostly cloudy breezy
6/23/97	1406	23E	***B***	<i>Cnemidophorus tigris</i>	20	mostly cloudy breezy
6/23/97	1418	23A	***B***	<i>Cnemidophorus tigris</i>	21	mostly cloudy windy
6/23/97	1419	23A	***B***	<i>Cnemidophorus tigris</i>	21	mostly cloudy windy
6/23/97	1419	23A	***B***	<i>Cnemidophorus tigris</i>	21	mostly cloudy windy
6/23/97	1419	23A	***B***	<i>Cnemidophorus tigris</i>	21	mostly cloudy windy

Date	Time	Trap #	traptype	Genus and species	Temp C	Weather
6/23/97	1423	23B	***C***	<i>Cnemidophorus tigris</i>	21	mostly cloudy windy
6/23/97	1423	23B	***C***	<i>Cnemidophorus tigris</i>	21	mostly cloudy windy
6/23/97	1429	22G	***A***	<i>Cnemidophorus tigris</i>	20	mostly cloudy windy
6/23/97	1431	22H	***B***	<i>Cnemidophorus tigris</i>	20	mostly cloudy windy
6/23/97	1455	21A	***A***	<i>Cnemidophorus tigris</i>	21	mostly cloudy breezy
6/23/97	1455	21A	***A***	<i>Cnemidophorus tigris</i>	21	mostly cloudy breezy
6/23/97	1455	21A	***A***	<i>Gambusia holbrooki</i>	21	mostly cloudy breezy
7/9/97	1604	00F	***D***	<i>Cnemidophorus tigris</i>	29	mostly cloudy breezy
7/10/97	1058	14F	***B***	<i>Cnemidophorus tigris</i>	18	mostly cloudy windy
7/10/97	1110	15A	***C***	<i>Cnemidophorus tigris</i>	19	mostly cloudy windy
7/10/97	1136	15I	***C***	<i>Uta stansburiana</i>	18	mostly cloudy windy
7/10/97	1342	01B	***D***	<i>Cnemidophorus tigris</i>	22	partly cloudy breezy
7/10/97	1458	11B	***F***	<i>Cnemidophorus tigris</i>	27	partly cloudy breezy
7/10/97	1501	12B	***F***	<i>Cnemidophorus tigris</i>	26	partly cloudy breezy
7/10/97	1617	23A	***B***	<i>Cnemidophorus tigris</i>	23	partly cloudy breezy
7/10/97	1622	23C	***D***	<i>Cnemidophorus tigris</i>	23	partly cloudy breezy
7/10/97	1628	22H	***B***	<i>Cnemidophorus tigris</i>	24	partly cloudy breezy
7/10/97	1640	22E	***C***	<i>Cnemidophorus tigris</i>	24	partly cloudy breezy
7/10/97	1649	21A	***A***	<i>Cnemidophorus tigris</i>	25	partly cloudy breezy
7/10/97	1651	21B	***B***	<i>Cnemidophorus tigris</i>	24	partly cloudy breezy
7/10/97	1701	22B	***D***	<i>Cnemidophorus tigris</i>	26	partly cloudy breezy
7/10/97	1723	26B	***F***	<i>Phrynosoma platyrhinos</i>	27	partly cloudy breezy
7/10/97	1734	26A	***E***	<i>Cnemidophorus tigris</i>	26	partly cloudy breezy
7/11/97	1209	00F	***D***	<i>Cnemidophorus tigris</i>	24	clear breezy
7/11/97	1219	5A	***A***	<i>Cnemidophorus tigris</i>	25	clear breezy
7/11/97	1219	5A	***A***	<i>Cnemidophorus tigris</i>	25	clear breezy
7/12/97	1121	15B	***D***	<i>Cnemidophorus tigris</i>	23	clear windy
7/12/97	1130	15F	***D***	<i>Cnemidophorus tigris</i>	23	clear windy
7/12/97	1146	15L	***B***	<i>Cnemidophorus tigris</i>	23	clear windy
7/12/97	1216	02F	***B***	<i>Cnemidophorus tigris</i>	23	clear windy
7/12/97	1237	00D	***B***	<i>Cnemidophorus tigris</i>	24	clear windy
7/12/97	1307	2D	***D***	<i>Cnemidophorus tigris</i>	25	clear windy
7/12/97	1340	7B	***F***	<i>Cnemidophorus tigris</i>	28	clear windy
7/12/97	1355	12B	***F***	<i>Cnemidophorus tigris</i>	27	clear windy
7/13/97	1304	25A	***E***	<i>Cnemidophorus tigris</i>	29	clear breezy
7/13/97	1310	27A	***E***	<i>Cnemidophorus tigris</i>	31	clear breezy
7/13/97	1316	29A	***E***	<i>Cnemidophorus tigris</i>	32	clear breezy
7/13/97	1401	22I	***C***	<i>Cnemidophorus tigris</i>	32	clear breezy
7/13/97	1407	22K	***A***	<i>Cnemidophorus tigris</i>	33	clear breezy
7/13/97	1430	00A	***C***	<i>Cnemidophorus tigris</i>	33	clear breezy
7/13/97	1454	6B	***B***	<i>Cnemidophorus tigris</i>	34	clear breezy
7/14/97	851	7B	***F***	<i>Cnemidophorus tigris</i>	23	clear breezy
7/14/97	901	10A	***E***	<i>Cnemidophorus tigris</i>	26	clear calm
7/14/97	908	11B	***F***	<i>Cnemidophorus tigris</i>	28	clear calm
7/14/97	943	3D	***D***	<i>Cnemidophorus tigris</i>	26	clear breezy
7/14/97	943	3D	***D***	<i>Cnemidophorus tigris</i>	26	clear breezy
7/14/97	949	2B	***B***	<i>Cnemidophorus tigris</i>	26	clear breezy
7/14/97	1029	02F	***B***	<i>Cnemidophorus tigris</i>	29	clear breezy
7/14/97	1035	02C	***C***	<i>Cnemidophorus tigris</i>	29	clear breezy
7/14/97	1120	01A	***C***	<i>Cnemidophorus tigris</i>	31	clear breezy
7/14/97	1126	01D	***B***	<i>Cnemidophorus tigris</i>	32	clear breezy
7/14/97	1153	14A	***A***	<i>Phrynosoma platyrhinos</i>	32	clear breezy
7/14/97	1158	14C	***C***	<i>Phrynosoma platyrhinos</i>	32	clear breezy
7/14/97	1214	15A	***C***	<i>Cnemidophorus tigris</i>	33	clear breezy
7/14/97	1216	15B	***D***	<i>Cnemidophorus tigris</i>	33	clear breezy
7/14/97	1225	15D	***B***	<i>Cnemidophorus tigris</i>	35	clear breezy
7/14/97	1241	15K	***A***	<i>Cnemidophorus tigris</i>	35	clear breezy
7/14/97	1245	15L	***B***	<i>Cnemidophorus tigris</i>	36	clear breezy
7/14/97	1249	15M	***C***	<i>Cnemidophorus tigris</i>	36	clear breezy
7/15/97	1345	5B	***B***	<i>Cnemidophorus tigris</i>	37	clear breezy
7/15/97	1401	3A	***A***	<i>Cnemidophorus tigris</i>	37	clear breezy
7/15/97	1418	2D	***D***	<i>Cnemidophorus tigris</i>	34	clear windy
7/15/97	1505	14J	***B***	<i>Uta stansburiana</i>	36	clear windy

Date	Time	Trap #	traptype	Genus and species	Temp C	Weather
7/15/97	1509	15B	***D***	<i>Cnemidophorus tigris</i>	36	clear windy
7/15/97	1523	15H	***B***	<i>Uta stansburiana</i>	36	clear windy
7/15/97	1644	10B	***F***	<i>Cnemidophorus tigris</i>	38	clear breezy
7/16/97	717	27A	***E***	<i>Cnemidophorus tigris</i>	21	clear breezy
7/16/97	722	28A	***E***	<i>Cnemidophorus tigris</i>	21	clear breezy
7/16/97	728	29B	***F***	<i>Cnemidophorus tigris</i>	22	clear breezy
7/16/97	800	22D	***B***	<i>Cnemidophorus tigris</i>	24	clear breezy
7/16/97	804	22E	***C***	<i>Cnemidophorus tigris</i>	24	clear breezy
7/16/97	817	22J	***D***	<i>Cnemidophorus tigris</i>	24	clear windy
7/16/97	817	22J	***D***	<i>Cnemidophorus tigris</i>	24	clear windy
7/16/97	817	22J	***D***	<i>Cnemidophorus tigris</i>	24	clear windy
7/16/97	825	23A	***B***	<i>Cnemidophorus tigris</i>	25	clear windy
7/16/97	1028	15D	***B***	<i>Cnemidophorus tigris</i>	30	clear breezy
7/16/97	1031	15E	***C***	<i>Cnemidophorus tigris</i>	30	clear breezy
7/16/97	1037	15G	***A***	<i>Uta stansburiana</i>	31	clear breezy
7/16/97	1130	03H	***A***	<i>Cnemidophorus tigris</i>	33	clear breezy
7/16/97	1206	01E	***C***	<i>Cnemidophorus tigris</i>	34	clear breezy
7/16/97	1255	10A	***E***	<i>Cnemidophorus tigris</i>	37	clear breezy
7/16/97	1405	8D	***D***	<i>Cnemidophorus tigris</i>	33	clear breezy
7/16/97	1414	4B	***B***	<i>Cnemidophorus tigris</i>	35	clear breezy
7/16/97	1417	5A	***A***	<i>Cnemidophorus tigris</i>	36	clear breezy
7/17/97	804	14B	***B***	<i>Cnemidophorus tigris</i>	26	cloudy breezy
7/17/97	833	15F	***D***	<i>Cnemidophorus tigris</i>	21	cloudy breezy
7/17/97	845	15L	***B***	<i>Cnemidophorus tigris</i>	22	cloudy breezy
7/17/97	932	00E	***C***	<i>Cnemidophorus tigris</i>	24	cloudy breezy
7/17/97	1005	9A	***E***	<i>Cnemidophorus tigris</i>	30	cloudy breezy
7/17/97	1005	9A	***E***	<i>Sceloporus occidentalis</i>	30	cloudy breezy
7/17/97	1129	00G	***A***	<i>Cnemidophorus tigris</i>	27	cloudy breezy
7/17/97	1130	00H	***B***	<i>Cnemidophorus tigris</i>	27	cloudy breezy
7/17/97	1310	22C	***A***	<i>Cnemidophorus tigris</i>	27	cloudy breezy
7/17/97	1322	22A	***C***	<i>Cnemidophorus tigris</i>	29	cloudy breezy
7/19/97	956	14I	***A***	<i>Uta stansburiana</i>	25	clear breezy
7/19/97	1006	15C	***A***	<i>Uta stansburiana</i>	26	clear breezy
7/19/97	1120	6A	***A***	<i>Cnemidophorus tigris</i>	30	clear breezy
7/19/97	1125	6C	***C***	<i>Cnemidophorus tigris</i>	30	partly cloudy breezy
7/19/97	1132	4C	***C***	<i>Cnemidophorus tigris</i>	28	partly cloudy light breeze
7/19/97	1136	4B	***B***	<i>Cnemidophorus tigris</i>	29	partly cloudy light breeze
7/19/97	1158	7B	***F***	<i>Cnemidophorus tigris</i>	64	partly cloudy light breeze
7/19/97	1158	7B	***F***	<i>Cnemidophorus tigris</i>	64	partly cloudy light breeze
7/19/97	1205	9B	***F***	<i>Cnemidophorus tigris</i>	36	partly cloudy light breeze
7/19/97	1205	9B	***F***	<i>Uta stansburiana</i>	36	partly cloudy light breeze
7/19/97	1212	11A	***E***	<i>Cnemidophorus tigris</i>	36	partly cloudy light breeze
7/19/97	1214	11B	***F***	<i>Cnemidophorus tigris</i>	35	partly cloudy light breeze
7/19/97	1218	12B	***F***	<i>Uta stansburiana</i>	34	partly cloudy light breeze
7/19/97	1314	00C	***A***	<i>Cnemidophorus tigris</i>	31	partly cloudy light breeze
7/19/97	1316	00D	***B***	<i>Cnemidophorus tigris</i>	30	partly cloudy light breeze
7/19/97	1319	00G	***A***	<i>Cnemidophorus tigris</i>	29	partly cloudy light breeze
7/19/97	1321	00H	***B***	<i>Cnemidophorus tigris</i>	29	partly cloudy light breeze
7/19/97	1321	00H	***B***	<i>Cnemidophorus tigris</i>	29	partly cloudy light breeze
7/19/97	1359	13A	***C***	<i>Cnemidophorus tigris</i>	27	partly cloudy light breeze
7/20/97	939	23I	***B***	<i>Cnemidophorus tigris</i>	27	clear calm
7/20/97	942	00A	***C***	<i>Cnemidophorus tigris</i>	27	clear calm
7/20/97	947	23D	***A***	<i>Cnemidophorus tigris</i>	27	clear calm
7/20/97	949	23E	***B***	<i>Cnemidophorus tigris</i>	27	clear calm
7/20/97	1000	23A	***B***	<i>Cnemidophorus tigris</i>	29	clear calm
7/20/97	1004	23B	***C***	<i>Cnemidophorus tigris</i>	28	clear calm
7/20/97	1033	22A	***C***	<i>Cnemidophorus tigris</i>	32	clear calm
7/20/97	1033	22A	***C***	<i>Cnemidophorus tigris</i>	32	clear calm
7/20/97	1048	25A	***E***	<i>Cnemidophorus tigris</i>	30	clear calm
7/20/97	1100	30B	***F***	<i>Cnemidophorus tigris</i>	30	clear calm
7/20/97	1201	03G	***B***	<i>Cnemidophorus tigris</i>	34	clear calm
7/20/97	1308	15A	***C***	<i>Uta stansburiana</i>	35	clear breezy

Date	Time	Trap #	traptype	Genus and species	Temp C	Weather
7/20/97	1314	15C	***A***	<i>Uta stansburiana</i>	35	clear breezy
7/20/97	1323	15G	***A***	<i>Cnemidophorus tigris</i>	35	clear breezy
7/20/97	1332	15K	***A***	<i>Cnemidophorus tigris</i>	36	clear calm
7/20/97	1430	6D	***D***	<i>Cnemidophorus tigris</i>	36	clear breezy
7/20/97	1439	5A	***A***	<i>Cnemidophorus tigris</i>	35	clear breezy
7/21/97	1527	15E	***C***	<i>Cnemidophorus tigris</i>	37	mostly cloudy breezy
7/21/97	1538	15I	***C***	<i>Cnemidophorus tigris</i>	35	mostly cloudy windy
7/21/97	1540	15J	***D***	<i>Cnemidophorus tigris</i>	34	mostly cloudy windy
7/21/97	1653	7B	***F***	<i>Cnemidophorus tigris</i>	29	mostly cloudy breezy
7/21/97	1656	7A	***E***	<i>Uta stansburiana</i>	30	partly cloudy windy
7/22/97	727	23I	***B***	<i>Cnemidophorus tigris</i>	22	clear breezy
7/22/97	759	22H	***B***	<i>Cnemidophorus tigris</i>	24	clear breezy
7/22/97	812	22C	***A***	<i>Cnemidophorus tigris</i>	25	clear breezy
7/22/97	848	29A	***E***	<i>Cnemidophorus tigris</i>	28	clear breezy
7/22/97	853	30A	***E***	<i>Cnemidophorus tigris</i>	26	clear breezy
7/22/97	1026	02F	***B***	<i>Cnemidophorus tigris</i>	29	clear breezy
7/22/97	1039	03D	***D***	<i>Cnemidophorus tigris</i>	30	clear breezy
7/22/97	1047	13B	***D***	<i>Cnemidophorus tigris</i>	32	clear breezy
7/22/97	1050	13C	***C***	<i>Cnemidophorus tigris</i>	32	clear breezy
7/22/97	1056	03I	***B***	<i>Uta stansburiana</i>	32	clear breezy
7/22/97	1154	6A	***A***	<i>Cnemidophorus tigris</i>	32	clear breezy
7/22/97	1226	7B	***F***	<i>Cnemidophorus tigris</i>	33	clear breezy
7/23/97	834	14A	***A***	<i>Cnemidophorus tigris</i>	25	clear breezy
7/23/97	839	14C	***C***	<i>Phrynosoma platyrhinos</i>	25	clear breezy
7/23/97	1032	03C	***C***	<i>Cnemidophorus tigris</i>	29	clear breezy
7/23/97	1046	03H	***A***	<i>Cnemidophorus tigris</i>	31	clear windy
7/23/97	1056	23H	***A***	<i>Cnemidophorus tigris</i>	30	clear windy
7/23/97	1131	22F	***D***	<i>Cnemidophorus tigris</i>	33	clear windy
7/23/97	1225	11A	***E***	<i>Cnemidophorus tigris</i>	37	clear breezy
7/23/97	1259	1B	***B***	<i>Cnemidophorus tigris</i>	33	clear breezy
7/24/97	833	2A	***A***	<i>Phrynosoma platyrhinos</i>	24	clear calm
7/24/97	939	7B	***F***	<i>Cnemidophorus tigris</i>	31	clear breezy
7/24/97	1037	4C	***C***	<i>Uta stansburiana</i>	30	clear breezy
7/24/97	1057	13A	***C***	<i>Cnemidophorus tigris</i>	34	clear breezy
7/24/97	1238	23H	***A***	<i>Uta stansburiana</i>	32	clear breezy
7/24/97	1348	25A	***E***	<i>Cnemidophorus tigris</i>	34	partly cloudy calm
7/24/97	1354	26B	***F***	<i>Cnemidophorus tigris</i>	36	partly cloudy breezy
7/24/97	1522	14J	***B***	<i>Uta stansburiana</i>	34	partly cloudy breezy
7/24/97	1526	15B	***D***	<i>Cnemidophorus tigris</i>	35	partly cloudy breezy
7/24/97	1536	15E	***C***	<i>Cnemidophorus tigris</i>	37	partly cloudy breezy
7/24/97	1556	15L	***B***	<i>Cnemidophorus tigris</i>	38	partly cloudy breezy