

**UNITED STATES  
DEPARTMENT OF THE INTERIOR  
BUREAU OF LAND MANAGEMENT  
Northwest Oregon District Office  
1717 Fabry Road, S.E.  
Salem, Oregon 97306**

**Golden Nectar Timber Sale  
ORN02-TS-2026.0203  
Date: June 22, 2026**

**TIMBER SALE PROSPECTUS**

**THIS IS A PROSPECTUS ONLY. ATTACHMENTS MAY NOT INCLUDE ALL EXHIBITS REFERRED TO IN THE CONTRACT. THE COMPLETE CONTRACT, INCLUDING ALL EXHIBITS, IS AVAILABLE FOR INSPECTION AT THE NORTHWEST OREGON DISTRICT OFFICE.**

NOTICE IS HEREBY GIVEN that the Bureau of Land Management will offer for sale timber as described herein for oral auction, pursuant to Instructions to Bidders, as stated on Form No. 5440-9. Written and oral bids will be received by the District Manager, or designated representative, in the timber sale room at the District Office, 1717 Fabry Road, S.E., Salem, Oregon. Written bids and deposits will be accepted beginning at 8:30 a.m. and the timber sale oral auction will commence at 9:00 a.m., on Wednesday, July 22, 2026. Before bids are submitted, full information concerning the timber, the conditions of sale and submission of bids, including appraised prices per species, should be obtained from the above District Manager, or designated representative. The right is hereby reserved to waive technical defects in this advertisement and to reject any or all bids. The United States reserves the right to waive any informality in bids received whenever such waiver is in the interest of the United States.

THIS PROSPECTUS does not constitute the decision document for purposes of appeal of a forest management decision. Consistent with 43 CFR Subpart 5003.2(b), the date the BLM posts the forest management decision on the BLM's ePlanning website establishes the effective date of the decision for purposes of an administrative appeal. The decision was posted to the BLM's ePlanning website on May 8, 2026, referring to the 2025 Aloha Trout Forest Management Project, DOI-BLM-ORWA-N020-2025-0010-EA. For the purposes of 43 CFR 5401.0-6 and 5430.0-6, this advertisement is being published on June 22, 2026 and June 29, 2026.

AN ENVIRONMENTAL ASSESSMENT was prepared for this timber sale tract, and a Finding of No Significant Impact has been documented. These documents are available for inspection as background for each timber sale tract at the Northwest Oregon District Office.

A WRITTEN BID on Form 5440-9 at not less than the advertised appraised price on a unit basis per species and the required minimum bid deposit shall be required to participate in oral bidding. Forms can be found at the following website under Forestry Forms, 5000-5999. <https://www.blm.gov/services/electronic-forms>.

THE SUCCESSFUL BIDDER, as a condition of award, will be required to sign Form 5430-11, a certification that the bid was arrived at by the bidder or offeror independently, and was tendered without collusion with any other bidder or offeror. Also, Form 5450-17, Export Determination must be completed by the successful bidder. To expedite procedure, this form should be completed and submitted with the written bid.

THE VOLUMES LISTED herein are estimates only. The sale volumes listed are based on 16-foot taper breaks which must be taken into consideration if comparisons are made with volume predictions based on other standards. The volumes based on 32-foot taper breaks are shown for comparison purposes. No sale shall be made for less than the advertised appraised price. The Purchaser shall be liable for the total purchase price, without regard to the amount bid per unit, even though the quantity of timber actually cut or removed or designated for taking is more or less than the estimated volume or quantity so listed.

THIS TIMBER SALE has been cruised based upon Eastside Scribner board foot measure. The minimum bid figures shown by species are dollars per thousand board feet (MBF). The minimum bid increment will be \$0.10 per MBF.

A PERFORMANCE BOND in an amount not less than 20 percent of the total purchase price will be required for all contracts of \$2,500 or more. A minimum performance bond of not less than \$500 will be required for all installment contracts less than \$2,500.

QUALIFIED SMALL BUSINESS concerns may apply to SBA for a loan to provide financing for access road construction required under the terms of qualifying timber sale contracts, and necessary contract changes will be made. Approval of loan applications rests with SBA and may be contingent on availability of funds. Applicants for such loans shall notify BLM of their intention to apply for a loan.

PRE-AWARD QUALIFICATIONS. The high bidder may be required to furnish information to determine the ability to perform the obligations of the contract. If the high bidder is determined not qualified, responsible or refuses to respond within fifteen (15) days of a request for information pertaining to qualifications, the contract may be offered and awarded for the amount of the high bid to the highest of the bidders who is qualified, responsible, and willing to accept the contract.

LOG EXPORT AND SUBSTITUTION: All timber sales, including timber from Federal rights-of-ways, shall be subject to the restrictions relating to the export and substitution of unprocessed timber from the United States in accordance with P.L. 94-165 and 43 CFR 5400 and 5420, as amended.

LOG EXPORT AND SUBSTITUTION RESTRICTIONS: Excepting Port-Orford-cedar, all timber offered for sale hereunder is restricted from export from the United States in the form of unprocessed timber and is prohibited from being used as a substitute for exported private timber. The BLM has revised the log export restrictions special provision to reduce the log branding and painting requirements. The new requirements include branding of one end of all logs with a scaling diameter of over 10 inches. All loads of 11 logs or more, regardless of the diameter of the logs, will have a minimum of 10 logs branded on one end. All logs will be branded on loads of 10 logs or less. One end of all branded logs will be marked with yellow paint. At the discretion of the Contracting Officer, the Purchaser may be required to brand and paint all logs. The Purchaser shall bear any increased costs for log branding and painting.

CONTRACT MODIFICATION, SUSPENSION OR TERMINATION: A revised Special Provision has been added to the contract which enables the Contracting Officer to suspend the contract to facilitate protection of certain plant or animal species, and/or to modify or terminate the contract when necessary to: (1) Comply with the Endangered Species Act or to prevent incidental take of northern spotted owls in accordance with management direction in the Record of Decision (ROD) and Resource Management Plan (RMP), or; (2) Comply with a court order, or; (3) Protect species which were identified for protection through survey and manage and/or protection buffer standards and guidelines or management direction established in the ROD and RMP.

ADDITIONAL INFORMATION concerning this timber sale tract is available at the above District Office. A copy of the timber sale contract is also available for inspection at the District Office. The prospectus for this/these sale(s) is also available online at: <https://www.blm.gov/programs/natural-resources/forests-and-woodlands/timber-sales>. The prospectus includes maps and tables that cannot be made Section 508 compliant. For help with its data or information, please contact the Northwest Oregon District Office at 503-375-5646.

## TIMBER SALE NOTICE

NORTHWEST OREGON DISTRICT  
MARYS PEAK FIELD OFFICE  
ALSEA-RICKREALL MASTER UNIT

SALE DATE: July 22, 2026

CONTRACT NO. ORN02-TS-2026.0203: GOLDEN NECTAR: LUMP SUM:  
BENTON COUNTY, OREGON: O&C: ORAL AUCTION: BID DEPOSIT REQUIRED: \$340,700.00.

All timber designated for cutting on: S1/2 NE1/4, S1/2 NW1/4, and S1/2 Section 3, T. 14 S., R. 07 W.,  
Willamette Meridian.

### **THIS TIMBER SALE HAS BEEN CRUISED BASED UPON EASTSIDE SCRIBNER MEASURE.**

Minimum bid figures shown by species are dollars per thousand board feet (MBF).

The minimum bid increment will be \$0.10 per MBF.

<b>Approx. No. Merchantable Trees</b>	<b>Est. Vol. MBF 32' Log</b>	<b>Species</b>	<b>Est. Vol. MBF 16' Log</b>	<b>Appraised Price Per MBF</b>	<b>Estimated Volume Times Appraised Price</b>
18,300	8,858	Douglas-fir	10,546	\$282.80	\$2,982,408.80
2,780	1,197	Western hemlock	1,392	\$103.70	\$144,350.40
2,653	420	Red alder	553	\$117.60	\$65,032.80
824	280	Western Redcedar	354	\$561.80	\$198,877.20
2,293	231	Bigleaf maple	304	\$24.70*	\$7,508.80
294	115	Grand fir	145	\$60.60	\$8,787.00
<b>27,144</b>	<b>11,101</b>	<b>Totals</b>	<b>13,294</b>		<b>\$3,406,965.00</b>

\*Minimum Stumpage values were used to compute the Appraised Price/MBF (10% of Pond Value)

**LOG EXPORT AND SUBSTITUTION RESTRICTIONS:** All timber offered for sale hereunder is restricted from export from the United States in the form of unprocessed timber and prohibited from substitution of exported private timber.

**CRUISE INFORMATION:** The timber volumes in the Regeneration Harvest Areas were cruised using variable plot cruise method for estimating board foot volumes in 16-foot logs lengths. The timber volumes in the Right-of-Way areas were 100% cruised in 16-foot log lengths. Approximately 0% of the total sale volume is salvage material. With respect to merchantable trees of all species; the average tree is 18.5 inches DBHOB; the average log contains 95 bd. ft.; the total gross volume is approximately 14,149 MBF; and 94% recovery is expected.

**CUTTING AREA:** A total of three (3) units totaling approximately two-hundred thirty-five (235) acres shall be Regeneration Harvest, approximately three (3) acres shall be Right of Way Clearing, and approximately twenty-one trees painted blue for removal. Acres shown on Exhibit A have been computed in accordance with Bureau of Land Management collection standards. Acreage was calculated based on Global Positioning System traverse procedures including differential correction.

**DURATION OF CONTRACT:** Contract length will be 36 months for cutting and removal of timber.

**LOCATION:** The Golden Nectar Timber Sale is located approximately four (4) air miles east of Alsea, Oregon. From Alsea, drive east out Oregon Highway 34, Alsea Highway, for approximately one (1) mile, then turn right on Honey Grove Road. Drive approximately 1.4 miles east on Honey Grove Road, then turn right onto BLM road 14-7-5.1. Continue on BLM road 14-7-5.1 for approximately 0.25 miles then keep left onto BLM road 14-7-5.6 for 1.2 miles to the sale area. See general vicinity map and Exhibit E for details.

**Note: Prospective bidders may contact Macrina Lesniak @ (503) 507-6941 to answer questions or combination for 14-7-3.2 road access.**

ACCESS AND ROAD MAINTENANCE: Access is provided on Weyerhaeuser Company, Tall Corn Forestry LLC, and Bureau of Land Management controlled roads. In the use of Weyerhaeuser Company controlled roads – Purchaser Maintenance, the Purchaser shall enter into a license agreement with Weyerhaeuser Company, perform maintenance on 4.44 miles of road, and pay to Weyerhaeuser Company a road use fee of one hundred seven thousand eight hundred ten and 00/100 dollars (\$107,810.00), performance bond in the amount of \$15,000, and carry liability insurance with limits of \$1,000,000/\$1,000,000/1,000,000.

In the use of Tall Corn Forestry LLC controlled roads – Purchaser Maintenance, the Purchaser shall enter into a license agreement with Tall Corn Forestry LLC, perform maintenance on 1.73 miles of road, and pay to Tall Corn Forestry LLC a road use fee of twenty-five thousand four hundred and two and 59/100 dollars (\$25,402.59), performance bond in the amount of \$15,000, and carry liability insurance with limits of \$1,000,000/\$1,000,000/1,000,000.

In the use of Bureau of Land Management controlled roads – Purchaser Maintenance, the Purchaser will be required to perform maintenance on approximately 10.3 miles of road. The Purchaser shall pay the Government a road maintenance obligation for rockwear of eleven thousand five hundred eighty-eight and 24/100 dollars (\$11,588.24) for timber and mineral haul associated with the contract.

Purchaser maintenance shall include frequent blading and shaping of road surface; ditch, culvert, and catch basin cleaning; removal of minor slides and other debris. Roads shall be left in a condition to withstand adverse weather at the end of the seasonal operations.

ROAD CONSTRUCTION, IMPROVEMENT, AND RENOVATION: The purchaser will be required to do all work set forth below. The purchaser shall supply all materials unless otherwise indicated.

1. Construction:

P3, Sta 0+00 – Sta 17+89, 16-foot subgrade with 2-foot ditch  
Clearing and grubbing; Excavation; Culvert installation; Grading and compacting; Erosion control;  
Surfacing – Aggregate surface course, useable width 15 feet

P5, Sta 0+00 – Sta 9+08, 16-foot subgrade with 2-foot ditch  
Clearing and grubbing; Excavation; Culvert installation; Grading and compacting; Erosion control;  
Surfacing – Aggregate surface course, useable width 15 feet

P6, Sta 0+00 – Sta 7+15, 16-foot subgrade with 2-foot ditch  
Clearing and grubbing; Excavation; Culvert installation; Grading and compacting; Erosion control  
Surfacing – Aggregate surface course, useable width 15 feet

P7, Sta 0+00 – Sta 14+06, 16-foot subgrade with 2-foot ditch  
Clearing and grubbing; Excavation; Culvert installation; Grading and compacting; Erosion control;  
Surfacing – Aggregate surface course, useable width 15 feet

P8, Sta 0+00 – Sta 7+18, 16-foot subgrade with 2-foot ditch  
Clearing and grubbing; Excavation; Culvert installation; Grading and compacting; Erosion control;  
Surfacing – Aggregate surface course, useable width 15 feet

P9, Sta 0+00 – Sta 4+88, 16-foot subgrade with 2-foot ditch  
Clearing and grubbing; Excavation; Culvert installation; Grading and compacting; Erosion control;  
Surfacing – Aggregate surface course, useable width 15 feet

P10, Sta 0+00 – Sta 5+11, 16-foot subgrade with 2-foot ditch  
Clearing and grubbing; Excavation; Culvert installation; Grading and compacting; Erosion control;  
Surfacing – Aggregate surface course, useable width 15 feet

2. Improvement/Renovation:

14-7-2.2, MP 0.00-0.88, 16-foot subgrade with 2-foot ditch  
Roadside brushing; Grading and compacting; Erosion control; Surfacing – Aggregate surface course, useable width 15 feet

14-7-3.0, MP 0.00-0.66, 16-foot subgrade with 2-foot ditch  
Roadside brushing; Culvert installation; Grading and compacting; Erosion control; Surfacing – Aggregate surface course, useable width 15 feet

14-7-3.1, MP 0.00-0.58, 16-foot subgrade with 2-foot ditch  
Roadside brushing; Culvert installation; Grading and compacting; Erosion control; Surfacing – Aggregate surface course, useable width 15 feet

14-7-3.2, MP 0.00-0.85, 16-foot subgrade with 2-foot ditch  
Roadside brushing; Grading and compacting; Erosion control; Surfacing – Aggregate surface course, useable width 15 feet

14-7-4.1, MP 0.00-1.06, 16-foot subgrade with 2-foot ditch  
Clearing and grubbing; Roadside brushing; Culvert installation; Grading and compacting; Erosion control; Surfacing – Aggregate surface course, useable width 15 feet

14-7-4.2, MP 0.00-1.21, 16-foot subgrade with 2-foot ditch  
Roadside brushing; Grading and compacting; Erosion control; Surfacing – Aggregate surface course, useable width 15 feet

14-7-4.3, MP 0.00-0.61, 16-foot subgrade with 2-foot ditch  
Clearing and grubbing; Roadside brushing; Culvert installation; Grading and compacting; Erosion control; Surfacing – Aggregate surface course, useable width 15 feet

14-7-5.0, MP 0.25-0.36 and MP 1.36-3.67, 16-foot subgrade with 2-foot ditch  
Clearing and grubbing; Excavation; Roadside brushing; Grading and compacting; Erosion control; Surfacing – Aggregate surface course, useable width 15 feet

14-7-5.1, MP 0.00-0.50, 16-foot subgrade with 2-foot ditch  
Clearing and grubbing; Culvert installation; Roadside brushing; Grading and compacting; Erosion control; Surfacing – Aggregate surface course, useable width 15 feet

14-7-5.6, MP 0.00-0.68, 16-foot subgrade with 2-foot ditch  
Clearing and grubbing; Roadside brushing; Grading and compacting; Erosion control; Surfacing – Aggregate surface course, useable width 15 feet

14-7-10.0, MP 0.00-0.15, 16-foot subgrade with 2-foot ditch  
Clearing and grubbing; Excavation; Roadside brushing; Grading and compacting; Erosion control; Surfacing – Aggregate surface course, useable width 15 feet

3. Estimated Quantities:

Clearing and grubbing:  
8.49 acres

Excavation:  
20,277 cubic yards of common



TIMBER SALE CONTRACT SPECIAL PROVISIONS

Sec. 43.

RESERVED

a. All timber in the Reserve Area, including all trees painted orange and posted which are on or mark the boundaries of the Reserve Area, and mark the boundaries of rights-of-way, except for approximately twenty-one (21) Trees Painted Blue for Removal, as shown on Exhibit A, heretofore by the Government with blue paint above and below stump height in the approximate location in which trees are marked for cutting and removal in the Reserve Area.

b. All trees painted with orange paint above and below stump height located in the Regeneration Harvest Area, as shown on Exhibit A. Trees marked as above, and over forty (40) inches diameter at breast height (DBH), may not be cut under Section 44.i. unless specifically approved in advance and in writing by the Contracting Officer and may be required to be retained on site.

c. All existing snags and downed logs in the Regeneration Harvest Area, as shown on Exhibit A, which do not present a safety hazard as determined by the Authorized Officer. All snags and downed logs cut or moved for safety reasons shall be retained on site.

d. All trees in the Regeneration Harvest Area, as shown on Exhibit A, less than seven (7) inches diameter at breast height (DBH). All minor conifer and hardwood species, such as pacific yew, western white pine, Port Orford cedar, Pacific madrone, Pacific dogwood, and Golden chinquapin (if present in the stand).

Sec. 44. Special Provisions

LOGGING

a. Before beginning the operations on the Contract Area for the first time or after a shutdown of seven (7) or more days, the Purchaser shall notify the Authorized Officer in writing of the date they plan to begin operations. The Purchaser shall also notify the Authorized Officer in writing if he intends to cease operations for any period of seven (7) or more days.

b. Prior to the commencement of operations, the Purchaser shall obtain from the Authorized Officer written approval of a written operations and logging plan commensurate with the terms and conditions of the contract, which shall include measures needed to ensure protection of the environment and watershed. A pre-work conference between the Purchaser's authorized representative and the Authorized Officer must be held at a location designated by the Authorized Officer before the logging plan will be approved. All logging shall be done in accordance with the plan.

c. Excessive damage to reserve timber, as determined by the Authorized Officer, will result in suspension of operations until mitigation measures are in place to prevent further damage as approved by the Authorized Officer.

d. No trees may be felled, yarded, decked, or loaded in or through the Reserve Area, or adjacent private land except where explicitly allowed, as shown on Exhibit A. Trees will be directionally felled to lead for skidding and skyline yarding to minimize ground disturbance and entry into the Reserve Area. Tops, limbs, and other logging debris entering the Reserve Area from felling operations shall be pulled back into the Regeneration Harvest Area shown on Exhibit A, unless expressly authorized by other provisions of this contract.

e. In accordance with Exhibit F, which is attached hereto and made a part hereof, the Purchaser shall create two hundred sixty-one (261) snags, located in the Regeneration Harvest Area and Snag Creation Areas as shown on Exhibit F.

f. No ground-based yarding shall be conducted in the Regeneration Harvest – Ground-based Yarding area, as shown on Exhibit A, between October 15 of one calendar year and May 15 of the following calendar year, both days inclusive, or during any period of wet soil conditions as determined by the Authorized Officer, unless a written waiver is provided by the Authorize Officer.

g. In all Harvest Areas – All yarding shall be done by equipment capable of transporting the leading end of logs clear of the ground and operated entirely on designated skid roads and/or skyline corridors. Before felling and yarding any timber, except road right-of-way timber, the Purchaser shall locate designated skid trails and/or skyline corridors as follows:

1. Mark the location of designated skid roads and/or skyline corridors on the ground in a method approved by the Authorized Officer.
2. Space designated skid roads and/or skyline corridors at a minimum of one-hundred and fifty (150) feet apart unless otherwise agreed to in writing by the Authorized Officer.
3. Limit width of skid roads to a maximum of twelve (12) feet.
4. Obtain approval from the Authorized Officer of the location of all designated skid roads and/or skyline corridors.
5. Ground-based operations are limited to slopes of thirty-five (35) percent or less. Ground-based operations may be approved on slopes up to fifty (50) percent when using specialized equipment, operating on previously constructed skid trails, or accessing isolated areas over steep pitches. Existing skid roads should be used to the greatest extent possible and be located perpendicular to the slope to minimize road cutting.

h. At all landings in the sale area, all non-merchantable logs more than eight (8) inches in diameter at the large end and exceeding eight (8) feet in length shall be decked at a

location designated by the Authorized Officer. If a log or piece of log meeting or exceeding the above specifications is bucked and left in place, all portions of that log shall be yarded and decked at the designated location.

i. Before cutting and removing any trees necessary to facilitate logging in all Harvest Areas shown on Exhibit A, the Purchaser shall identify the location of the skid roads, cable yarding roads, and tailhold, tieback, guyline, lift, intermediate support, and danger trees on the ground in a manner approved by the Authorized Officer at the pre-work conference and documented in the Logging Plan. Said Purchaser identification of trees to be cut and removed does not constitute authority to proceed with cutting and removal. Certain trees over forty (40) inches diameter at breast height (DBH) may only be approved for cutting when there is no economically viable or practically feasible alternative, and if approved may be required to remain on site. In addition, before proceeding with cutting the following conditions must be met:

1. All skid roads and/or cable yarding roads upon which timber is identified by the Purchaser to be cut and removed in accordance with this special provision must be necessary for the safe and expeditious removal of timber sold under this contract and shall be limited to the minimum width necessary for yarding of logs with a minimum of damage to reserve trees, however, unless otherwise approved in writing by the Contracting Officer, the width of each skid road, and/or cable yarding road shall be limited to twelve (12) feet.

2. The Purchaser may immediately cut and remove additional timber to clear skid roads and cable yarding roads; and provide tailhold, tieback, guyline, lift and intermediate support trees; and clear danger trees when the trees have been marked with blue paint above and below stump height by the Authorized Officer and thereby approved for cutting and removal by the Authorized Officer. The volume of the timber to be sold will be determined by the Authorized Officer in accordance with Bureau of Land Management prescribed procedures. No timber may be cut or removed under terms of this provision unless sufficient installment payments have been made in accordance with Section 3.(b). of the contract or sufficient bonding has been provided in accordance with Section 3.(d). of the contract.

3. The Purchaser agrees that sale of this additional timber shall be accomplished by a unilateral modification of the contract executed by the Contracting Officer and that such timber shall be sold at the unit prices shown in Exhibit B of this contract unless: the value of the timber must be reappraised subject to the terms for contract extension set forth in Section. 9 of the contract; or, the Authorized Officer determines that the species of trees are not listed in Exhibit B of this contract or any Douglas-fir tree that exceeds 36 inches diameter at breast height or any western hemlock tree that exceeds 34 inches diameter at breast height shall be appraised and sold by bilateral modification of the contract at current fair market value in accordance with Section 8 of the contract.

4. This authorization for the Purchaser to cut and remove additional timber prior to the execution of a modification may be withdrawn by the Contracting Officer if the Authorized Officer determines that the Purchaser has cut and removed any tree not

previously marked and approved for cutting by the Authorized Officer, which under Section 10 of the contract constitutes a violation of the contract and under Section 13 of the contract may constitute a trespass rendering the Purchaser liable for damages under applicable law.

5. If authorization is withdrawn, the Contracting Officer shall issue a written notice to the Purchaser that the sale of additional timber under this special provision is no longer approved. In this case, the Purchaser shall inform the Authorized Officer at least one (1) working day prior to the need for cutting and removing any additional timber, and execute a bilateral modification prior to cutting for such additional approved timber at the unit prices shown in Exhibit B of the contract or in accordance with Section 8 or Section 9 of the contract as determined by the Authorized Officer in accordance with this provision. The Contracting Officer may issue a written order to the Purchaser to suspend, delay, or interrupt any or all contract work for the period of time deemed necessary and appropriate for the Government to safely measure and mark additional timber.

#### ROAD CONSTRUCTION, RENOVATION, IMPROVEMENT, MAINTENANCE AND USE

j. The Purchaser shall construct approximately 1.24 miles of road and renovate or improve approximately 8.8 miles of road in strict accordance with the plans and specifications shown on Exhibit C, which is attached hereto and a made a part hereof.

k. Any required road construction, improvement, or renovation shall be completed and accepted prior to the removal of any timber, except right-of-way timber, over that road.

l. No road renovation, improvement, or construction shall be conducted in the Contract Area, as shown on Exhibit A, between November 1 of one calendar year and April 30 of the following calendar year, both days inclusive, or during other periods of wet soil conditions as determined by the Authorized Officer.

m. No instream work shall be conducted in the Contract Area shown on Exhibit A between September 1 of one calendar year and June 30 of the following calendar year, both days inclusive, or during other periods of wet conditions as determined by the Authorized Officer, unless a written waiver is provided by the Authorized Officer.

n. The Purchaser is authorized to use the roads shown on Exhibit E for the removal of Government timber sold under the terms of this contract and the hauling of rock as required in Exhibit C, provided that the Purchaser pay the required maintenance obligation for road maintenance and rockwear described in Sec. 44.o. Any road shown on Exhibit E and requiring improvement or renovation in Exhibit C of this contract, shall be maintained by the Purchaser until receiving written acceptance of the improvement or renovation from the Authorized Officer.

o. The Purchaser shall pay the Government a road maintenance obligation for rockwear of eleven thousand five hundred eighty-eight and 24/100 dollars (\$11,588.24). If the total road maintenance obligation for rockwear does not exceed five hundred and 00/100 dollars (\$500.00), the Purchaser shall pay such amount in full prior to use of such roads. If the total road maintenance obligation for rockwear exceeds five hundred and 00/100 dollars (\$500.00), the Authorized Officer shall establish an installment schedule of payments of the maintenance obligation for rockwear.

p. In the use of Road No. 14-7-3.0 Seg A-B, No. 14-7-4.1 Seg A, No. 14-7-4.2, No. 14-7-4.3 Seg A, No. 14-7-5.0 Seg A-C, No. 14-7-5.6 the Purchaser shall comply with the conditions of Right-of-Way and Road Use Agreement No. S-805, between the United States of America and Weyerhaeuser Company. This document is available for inspection at the Northwest Oregon District Office. These conditions include:

1. Payment of a road use obligation of one hundred seven thousand eight hundred ten and 00/100 dollars (\$107,810.00) to Weyerhaeuser Company, payable at the time indicated in the License Agreement.
2. Prior to the use of said roads, the Purchaser shall furnish the Authorized Officer a properly signed copy of the executed License Agreement.
3. Default by the Purchaser of said Right-of-Way and Road Use Agreement, or any License Agreement executed pursuant thereto, for failure to pay appropriate road use fees shall be considered a violation of this contract. The amount of unpaid fees shall be considered as the amount of damage suffered by the Government as a result of the violation of this provision.

q. In the use of Road No. 14-7-2.2 and No. 14-7-3.2 the Purchaser shall comply with the conditions of Right-of-Way and Road Use Agreement No. S-805C, between the United States of America and Tall Corn Forestry LLC. This document is available for inspection at the Northwest Oregon District Office. These conditions include:

1. Payment of a road use obligation of one twenty-five thousand four hundred two and 59/100 dollars (\$25,402.59) to Tall Corn Forestry LLC, payable at the time indicated in the License Agreement.
2. Prior to the use of said roads, the Purchaser shall furnish the Authorized Officer a properly signed copy of the executed License Agreement.
3. Default by the Purchaser of said Right-of-Way and Road Use Agreement, or any License Agreement executed pursuant thereto, for failure to pay appropriate road use fees shall be considered a violation of this contract. The amount of unpaid fees shall be considered as the amount of damage suffered by the Government as a result of the violation of this provision.

r. The Purchaser shall perform any required road repair and maintenance work on the roads identified as Purchaser maintenance, under the terms of Exhibit D, Road Maintenance Specifications, of this contract, which is attached hereto and made a part hereof.

s. The Purchaser agrees that if they elect to use any other private road, which is the subject of a Right-of-Way agreement with the Government for the removal of Government timber sold under the terms of this contract, Purchaser shall request and agree to the modification of this contract to provide for such use and for allowances for amortization of the Government's shares of the capital investment of any such road.

t. With the prior written approval of the Authorized Officer, the Purchaser may arrange for cooperative maintenance with other users of roads included in Exhibit D and E; provided, that such cooperative arrangement shall not relieve the Purchaser of his liability for the maintenance and repair of such roads resulting from wear or damage, in accordance with this contract. The Purchaser shall furnish the Authorized Officer a copy of any cooperative maintenance agreements entered into with other users of these roads.

u. The Purchaser shall be required to secure written approval to use vehicles or haul forest products and equipment over Government owned or controlled roads when such vehicles or equipment exceeds the maximum allowable weights or dimensions established by the State for vehicles operating without a permit or if vehicles meet allowable non-permitted State vehicle weights, but the haul route crosses a structure or segment of road that is posted for reduced weights. The Purchaser agrees to abide by any special requirements included in said written approval. Details of such equipment shall be furnished to the Authorized Officer for evaluation of load characteristics at least fifteen (15) days prior to proposed move in.

Details shall include:

- A. Axle weights when fully loaded.
- B. Axle spacing.
- C. Transverse wheel spacing.
- D. Tire size.
- E. Outside width of vehicle.
- F. Operating speed.
- G. Frequency of use.
- H. Special features (e.g., running tracks, overhang loads, etc.).

The Purchaser shall be responsible for repair of any damage to roads or structures caused by the use of overweight or over-dimension vehicles or equipment: (1) without written approval; (2) in violation of the conditions of a written approval; or (3) in a negligent manner. The amount of actual damage shall be determined by the Authorized Officer following a technical inspection and evaluation.

ENVIRONMENTAL PROTECTION

v. In addition to the requirements set forth in Sec. 26 of this contract, the Purchaser shall complete grass seeding on exposed soil on all skyline roads, ground-based skid roads, landings, and any other exposed soil caused by contract obligations as directed by the Authorized Officer. Grass seed and suitable equipment to apply seed shall be furnished by the Purchaser.

Seed to be supplied shall meet the following requirements:

<u>SPECIES</u>	<u>RATE</u>
Red Fescue ( <i>festuca rubra</i> )	100%
Oregon Certified Seed (Blue Tag)	
Purity	97% minimum
Germination	85% minimum
Noxious Weed Content	None (Tested: None Found)

The Purchaser shall apply grass seed uniformly on the designated areas at a rate equal to ten (10) pounds per acre. Evidence of seed certification shall be furnished to the Authorized Officer prior to application. Grass seed which has become wet, moldy, or otherwise damaged shall not be provided.

w. In addition to the requirements set forth in Sec. 26 of this contract, in order to reduce or prevent the spread of noxious weeds to BLM lands, all road construction, piling, and ground-based logging equipment including loaders shall be cleaned of all plant parts and soil prior to entry onto Bureau of Land Management (BLM) lands. Equipment shall be inspected by the Authorized Officer at a site approved by the Authorized Officer to verify that the equipment had been reasonably cleaned prior to entry onto BLM lands.

FIRE PREVENTION

x. Primarily for purposes of fire prevention and control, the Purchaser shall, prior to the operation of power-driven equipment in construction or logging operations under this contract during the fire season or periods of fire danger, prepare a fire prevention and control plan to the satisfaction of the Authorized Officer. Purchaser shall take such measures for prevention and suppression of fire on the contract area and other adjacent Government lands used or traversed by Purchaser in connection with operations as are required by applicable laws and regulations. However, when in the opinion of the Authorized Officer, weather and other conditions affecting fire incidence and control make special precautions necessary to protect the contract area and said Government lands, Purchaser shall take such additional or other fire prevention and control measures as may be required by the Authorized Officer. The Purchaser shall comply with Oregon Department of Forestry Industrial Fire Precaution Level (IFPL) I Fire Season requirements. At IFPL II and III, additional fire prevention and control provisions may be added as determined by the Authorized Officer and specified in written instructions to the Purchaser to mitigate dry fuel and weather conditions.

### LOGGING RESIDUE REDUCTION

y. In addition to the requirements of Sec. 15 of this contract, and notwithstanding the Purchasers satisfactory compliance with State laws and regulations regarding offsetting or abating the additional fire hazard created by this operation and the States willingness to release the Purchaser from liability for such hazard, the Purchaser shall remain responsible to the Government for performance of the following hazard reduction measure(s) required by this contract: Perform logging residue reduction and site preparation work on approximately ninety-one (91) acres of harvest area located within harvest units. The required work shall consist of any treatment or combination of treatments, as determined by the Authorized Officer and specified in writing by the Contracting Officer. The number of acres of each treatment shall be determined by the Authorized Officer. Prior to commencement of any operation under this Section of the contract, a slash disposal and pre-work conference between the Purchaser's representative and the Authorized Officer must be held at a location designated by the Authorized Officer. The number of acres of each treatment shall be determined by the Authorized Officer. All slash disposal shall be done in accordance with the plans developed at this pre-work conference. Slash, as defined for this section, shall mean all material (brush, limbs, tops, unmerchantable stems, and chunks) severed or knocked over as a result of Purchasers operations under the terms of this contract.

1. Excavator pile and burn slash within ground-based portion and along roads as directed by the Authorized Officer. Slash shall be piled by an excavator equipped with a hydraulic thumb. Finished piles shall be tight and free of dirt.

a. Unmerchantable logs greater than six (6) inches on the small end shall be left in place or positioned so that they will not be burned.

b. Pile slash less than six (6) inches in diameter.

c. Machine piles shall be located as far as possible from retention trees, snags, or unit boundaries to minimize damage unless approved by Authorized Officer.

d. Machine piles shall be kept free of dirt, stumps, and other non-wood debris and constructed as compactly as possible. There should be an adequate supply of finer fuels located within and under the covered area of the pile to ensure ignition of the larger fuels.

e. Machine piles within the ground-based yarding areas shall not be any larger than 25 feet wide, 25 feet long, and 25 feet high.

f. A minimum 10-foot by 10-foot cover of four (4) mil (0.004) inch thick polyethylene shall cap each machine pile to maintain a dry ignition point. The cover shall be firmly fixed to each pile to hold it in place. Plastic shall be held in place with woody debris or tied with rope or twine. The plastic must be secured so that it is held in place during strong wind conditions. The Purchaser is required to

furnish the covering materials. Covering shall be completed as directed by the Authorized Officer.

g. Cutting Areas shall be piled during the same season that they are logged.

2. Pile and burn landing slash within thirty (30) feet of the edge of each landing, all tops, broken pieces, limbs and debris more than one (1) inch in diameter at the large end and longer than three (3) feet in length shall be piled within fifteen (15) days of completion of hauling logs from that landing. Landing piles shall be kept free of dirt and located adjacent to roads at least twenty-five (25) feet from any Reserve Tree and/or as directed by the Authorized Officer. Upon completion of landing piling, the Purchaser shall prepare the landing piles for burning by securely covering each landing pile with four (4) mil (0.004) inch thick polyethylene plastic film at least 10 feet wide. Landing piles shall be covered sufficiently to allow for ignition in wet conditions as approved by the Authorized Officer. The plastic shall be oriented southwest to northeast. Pieces of burnable material shall be placed on top of the plastic to secure it from moving and to prevent it from blowing off during strong wind episodes. The Purchaser is required to furnish the covering materials. The timing of this covering work shall be in accordance with instructions from the Authorized Officer. No landing debris shall be dozed off the landing and covered with dirt. Debris, which has been buried and is determined to be the source of holdover fire shall be excavated by the Purchaser, at the Purchaser's expense, with a tractor and/or hydraulic excavator as directed by the Authorized Officer. If the structure of the landing piles will not permit adequate consumption of piled debris by burning, the Purchaser shall re-pile them at the direction of the Authorized Officer.

z. Notwithstanding the provisions of Sec. 15 of this contract, the Government shall assume all obligations for disposal or reduction of fire hazards created by Purchaser's operations on Government lands, except for burning and mop-up assistance as required herein, and measures required in Section 44.y. The Purchaser shall, under supervision of the Authorized Officer or designated representative, assist in preparing units for burning, burning, mop-up, and patrol by furnishing, at the Purchaser's own expense, the services of personnel and equipment on each unit as shown below:

1. For Igniting, Burning, Mop-up of Piles on Units:
  - a. One work leader(s) Firefighter Type 1 (FFT1) qualified according to National Wildfire Coordinating Group (NWCG) Wildland Fire Qualifications System guide, PMS 310-1) to supervise crew and equipment operations, and to serve as Purchaser's representative.
  - b. Ten-person crew Firefighter Type 2 (FFT2) qualified according to National Wildfire Coordination Group (NWCG) Wildland Fire Qualifications

System guide, PMS 310-1, with sufficient fuel for burning, six (6) drip torches, one (1) power saw, and one (1) backpack pump, one (1) tool for each crew member.

- c. The crew shall arrive on the project area with radios capable of inter-crew communications and communication with a BLM representative at a ratio of one (1) radio per every five (5) crewmembers.
- d. All ignition and mop-up personnel will be directly supervised by a BLM representative.

Aircraft and pilots used for Logging Residue Reduction or the suppression of escaped fires from Logging Residue Reduction operations, shall be acquired from a list of aircraft and pilots approved (i.e., carded for these specific activities) by the Office of Aircraft Services or the U.S. Forest Service. This list is available from BLM District Offices upon request.

All listed personnel shall be physically fit, experienced and fully capable of functioning as required. In addition, all listed personnel shall be qualified according to the National Wildfire Coordinating Group (NWCG) Wildland Fire Qualification System Guide, PMS-310-1 and provide documentation of these qualifications. On the day of ignition all listed personnel shall be fluent in speaking and understanding English, clothing shall consist of long pants and long-sleeved shirts and be of approved aramid fabric (Nomex™ or equivalent), as well as being free of diesel fuel oil. All personnel shall wear lug sole boots with minimum eight (8) inch tall uppers that provide ankle support, approved hardhats and leather gloves. Personnel who do not meet these requirements or do not have proper clothing and personal protective equipment (PPE) will not be allowed to participate. All listed tools and equipment shall be in good usable condition. All power-driven equipment shall be fully fueled and available for immediate use. During periods of use under this subsection, the Purchaser shall provide fuel and maintenance for all such power-driven equipment.

Except as provided hereafter for fire escapement, the Purchaser shall continue the required assistance in mop up on each cutting unit shown on Exhibit A for seventy-two (72) hours, as directed by the Authorized Officer within a five (5) day period commencing at 8:00 a.m. the day following the completion of ignition in that unit, or until released from such service by the Government, whichever occurs first.

In event of a fire escapement, the Purchaser's personnel and equipment shall, under supervision of the Authorized Officer, take action to control and mop up the escaped fire until released from such service by the Government. If it becomes necessary to use furnished personnel and equipment for the suppression of a fire which escapes from the prescribed fire area for a period beyond the remainder of the day in which the fire escapes, then the Government shall, at its option: (1) reimburse the Purchaser for such additional use of personnel and equipment at wage rates shown in the current Administratively Determined Pay Rates for the Western Area and at equipment rates shown in the current Oregon-Washington Interagency Fire Fighting Equipment Rental Rates schedule until the Purchaser is released from such service by the Government; or (2) release the Purchaser from additional suppression work and assume responsibility for suppressing the escaped fire.

In situations where an escaped fire is controlled and contained by an adequate fire break (i.e., trail, road, stream, rock formation, etc.), the Government may permit the Purchaser to remove personnel for that day; provided that all mop up work on the escaped fire is included with mop up work on the prescribed fire area. In such an event, the Purchaser must sign a statement of agreement to complete mop up work on all escaped fire areas concurrently with mop up work on the prescribed fire area.

In case of injury to personnel or damage to equipment furnished as required by this subsection, liability shall be borne by the Purchaser, unless such injury or damage is caused by Government negligence.

Time is of the essence in complying with this provision. In the event the Purchaser fails to provide the personnel and equipment required herein, the Purchaser shall be responsible for all additional cost incurred by the Government in disposing of slash including but not limited to the wages and other costs of providing federal employees and others as substitute labor force, the cost of providing substitute equipment and appropriate additional overhead expenses. If the Purchaser's failure results in a deferral of burning and new conditions necessitate additional personnel and equipment to accomplish the planned burn, the Purchaser also shall be responsible for such additional costs.

#### LOG EXPORT RESTRICTION

aa. Unless otherwise authorized in writing by the Contracting Officer, the Purchaser shall brand clearly and legibly one end of all logs with a scaling diameter (small end inside bark) of over ten (10) inches, prior to the removal of timber from the contract area. All loads of eleven (11) logs or more will have a minimum of ten (10) logs clearly and legibly branded on one end regardless of the diameter of the logs. All logs will be branded on loads of ten (10) logs or less. One end of all branded logs to be processed domestically will be marked with a three (3) square inch spot of highway yellow paint. The Purchaser will stop trucks for accountability monitoring at mutually agreed upon locations when notified by the Authorized Officer.

If multiple trailers (mule trains) are used, each bunked load shall be considered an individual load, and these guidelines will apply to each bunked load. If a flatbed stake trailer is used, each bundle will be treated as a separate load.

At the discretion of the Authorized Officer, the Purchaser may be required to brand and paint all logs. Any increased costs for log branding and painting shall be the responsibility of the Purchaser.



**TIMBER SALE CONTRACT MAP - ORN02-TS-2026.0203**

T. 14 S., R. 7 W., Section 3 W.M.

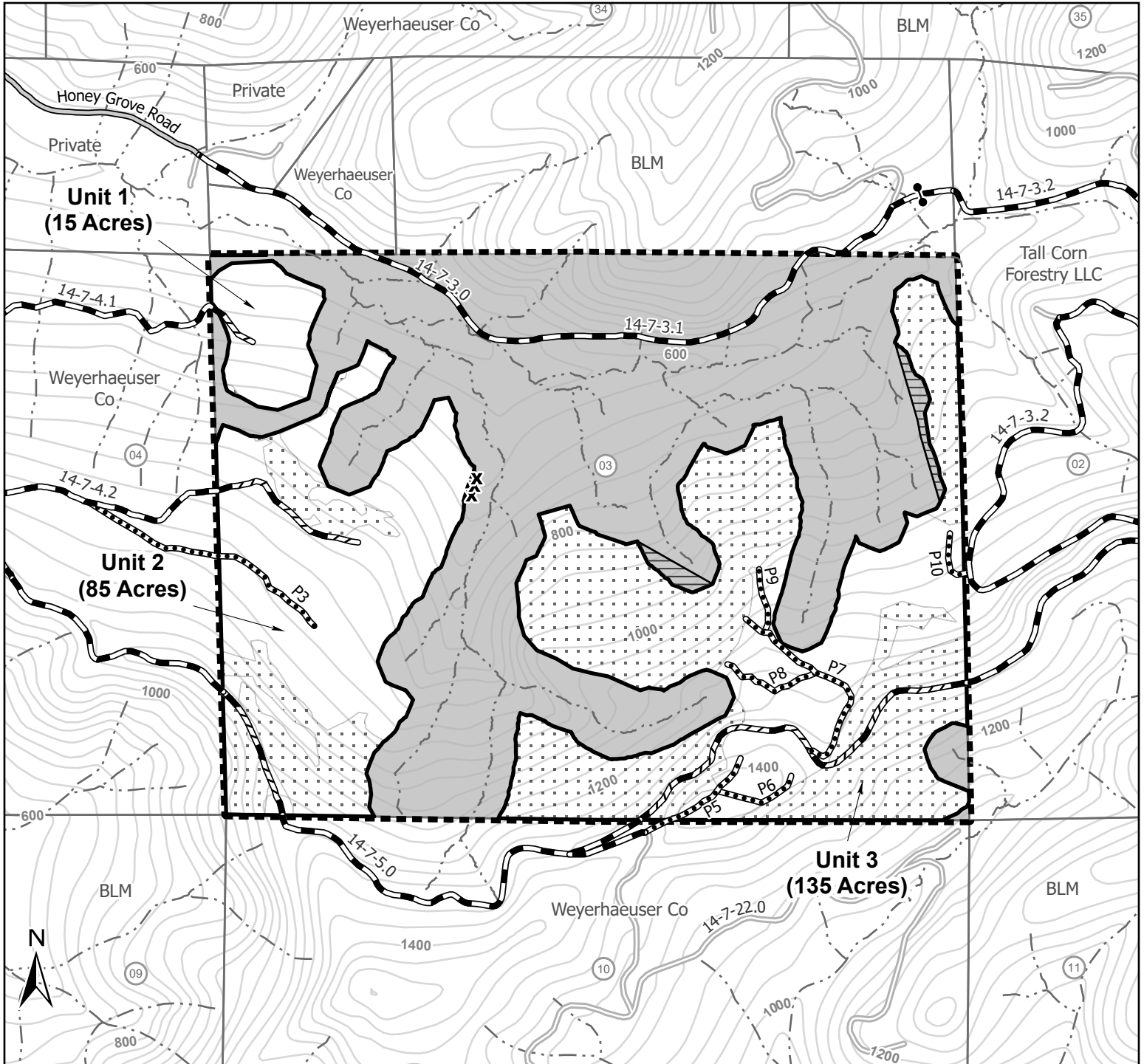

Contour Interval: 40 ft (LiDAR)

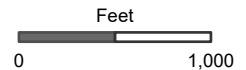
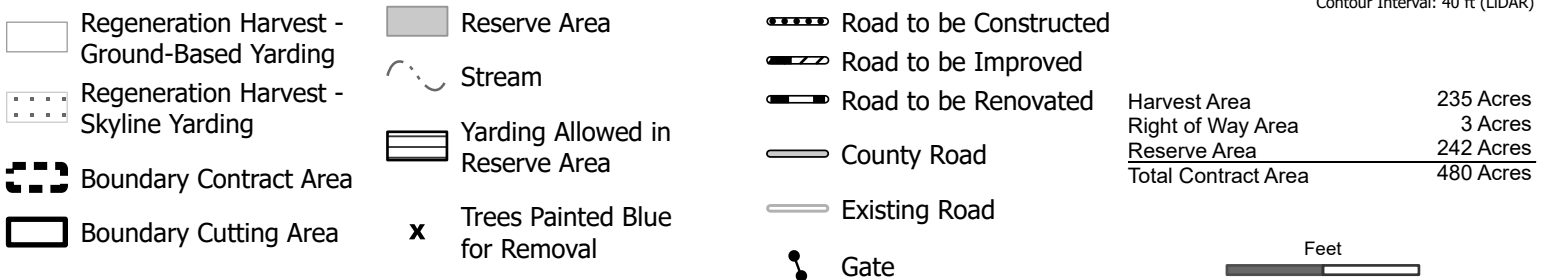

NOTES: Boundary of Harvest areas are painted orange and posted. Unit acres do not include existing roads or Rights-of-Way.

(February 1986)

ORN02-TS-2026.0203

**EXHIBIT B / PRE-SALE**

Golden Nectar

5450-003

The following estimates and calculations of value of timber sold are made solely as an administrative aid for determining: (1) adjustments made or credits given in accordance with Secs. 6, 9, or 11; (2) when payments are due; and (3) value of timber subject to any special bonding provisions. The value of timber will be determined by multiplying the value per acre as shown below, times the amount of acreage as determined by the Authorized Officer, which has been cut or removed or designated for taking. Except as provided in Sec. 2, Purchaser shall be liable for total purchase price even though quantity of timber actually cut or removed or designated for taking is less than the estimated volume or quantity shown. Cutting areas are shown on **Exhibit A**.

SPECIES	ESTIMATED VOLUME OR QUANTITY <i>(Units Specified)</i>		PRICE PER UNIT	ESTIMATED VOLUME OR QUANTITY X UNIT PRICE
Douglas Fir	10,546.0	MBF	\$282.80	\$2,982,408.80
Western Hemlock	1,392.0	MBF	\$103.70	\$144,350.40
Red Alder	553.0	MBF	\$117.60	\$65,032.80
Western Redcedar	354.0	MBF	\$561.80	\$198,877.20
Bigleaf Maple	304.0	MBF	\$24.70	\$7,508.80
Grandfir	145.0	MBF	\$60.60	\$8,787.00
<b>TOTALS</b>	<b>13,294.0</b>	<b>MBF</b>		<b>\$3,406,965.00</b>

The apportionment of the total purchase price is as follows:

Unit 1

Bigleaf Maple	19.0 MBF	X	\$24.70 =	\$469.30
Western Hemlock	88.0 MBF	X	\$103.70 =	\$9,125.60
Red Alder	35.0 MBF	X	\$117.60 =	\$4,116.00
Douglas Fir	663.0 MBF	X	\$282.80 =	\$187,496.40
Grandfir	9.0 MBF	X	\$60.60 =	\$545.40
Western Redcedar	22.0 MBF	X	\$561.80 =	\$12,359.60
<b>Total</b>	<b>836.0 Mbf</b>			<b>\$214,112.30 ÷ 15.0 acres = \$14,274.15/Acre</b>

Unit 2

Bigleaf Maple	109.0 MBF	X	\$24.70 =	\$2,692.30
Western Hemlock	497.0 MBF	X	\$103.70 =	\$51,538.90
Red Alder	198.0 MBF	X	\$117.60 =	\$23,284.80
Douglas Fir	3,759.0 MBF	X	\$282.80 =	\$1,063,045.20
Grandfir	52.0 MBF	X	\$60.60 =	\$3,151.20
Western Redcedar	126.0 MBF	X	\$561.80 =	\$70,786.80
<b>Total</b>	<b>4741.0 Mbf</b>			<b>\$1,214,499.20 ÷ 85.0 acres = \$14,288.23/Acre</b>

Unit 3

Bigleaf Maple	172.0 MBF	X	\$24.70 =	\$4,248.40
Western Hemlock	789.0 MBF	X	\$103.70 =	\$81,819.30
Red Alder	314.0 MBF	X	\$117.60 =	\$36,926.40
Douglas Fir	5,984.0 MBF	X	\$282.80 =	\$1,692,275.20
Grandfir	82.0 MBF	X	\$60.60 =	\$4,969.20
Western Redcedar	200.0 MBF	X	\$561.80 =	\$112,360.00
<b>Total</b>	<b>7541.0 Mbf</b>			<b>\$1,932,598.50 ÷ 135.0 acres = \$14,315.54/Acre</b>

(February 1986)

ORN02-TS-2026.0203

Golden Nectar

**EXHIBIT B / PRE-SALE**

5450-003

The following estimates and calculations of value of timber sold are made solely as an administrative aid for determining: (1) adjustments made or credits given in accordance with Secs. 6, 9, or 11; (2) when payments are due; and (3) value of timber subject to any special bonding provisions. The value of timber will be determined by multiplying the value per acre as shown below, times the amount of acreage as determined by the Authorized Officer, which has been cut or removed or designated for taking. Except as provided in Sec. 2, Purchaser shall be liable for total purchase price even though quantity of timber actually cut or removed or designated for taking is less than the estimated volume or quantity shown. Cutting areas are shown on **Exhibit A**.

Unit RW2

Bigleaf Maple	1.0 MBF	X	\$24.70	=	\$24.70
Western Hemlock	6.0 MBF	X	\$103.70	=	\$622.20
Red Alder	2.0 MBF	X	\$117.60	=	\$235.20
Douglas Fir	47.0 MBF	X	\$282.80	=	\$13,291.60
Grandfir	1.0 MBF	X	\$60.60	=	\$60.60
Western Redcedar	2.0 MBF	X	\$561.80	=	\$1,123.60
<hr/>					
Total	59.0 Mbf				\$15,357.90 ÷ 1.0 acres = \$15,357.90/Acre

Unit RW3

Bigleaf Maple	3.0 MBF	X	\$24.70	=	\$74.10
Western Hemlock	12.0 MBF	X	\$103.70	=	\$1,244.40
Red Alder	4.0 MBF	X	\$117.60	=	\$470.40
Douglas Fir	93.0 MBF	X	\$282.80	=	\$26,300.40
Grandfir	1.0 MBF	X	\$60.60	=	\$60.60
Western Redcedar	4.0 MBF	X	\$561.80	=	\$2,247.20
<hr/>					
Total	117.0 Mbf				\$30,397.10 ÷ 2.0 acres = \$15,198.55/Acre

U.S. DEPT. OF THE INTERIOR  
Bureau of Land Management  
NORTHWEST OREGON DISTRICT - OREGON  
TIMBER SALE CONTRACT

EXHIBIT C

Table of Contents

Section	Sheet	Description
	1	Table of Contents
	2	Road Specifications
100	3-9	General
150	10-11	Road Plan and Detail Sheet
200	12-13	Clearing and Grubbing
300	13-16	Excavation and Embankment
400	16-21	Pipe Culverts
500	21-23	Renovation of Existing Roads
600	23	Watering
1000	24-26	Aggregate Base Course – Crushed Rock
1200	27-30	Aggregate Surface Course – Crushed Rock
1700	29-30	Erosion Control
1800	31-35	Soil Stabilization
2100	35-36	Roadside Brushing
2700	37-38	Road Decommissioning
	38-55	Road Construction Worklist
	56-60	Typical Detail Sheets
	61-62	Road Plan Map

U.S. DEPT. OF THE INTERIOR  
 Bureau of Land Management  
 NORTHWEST OREGON DISTRICT - OREGON  
 TIMBER SALE CONTRACT

Road Specifications

Road Number and Segment	Class SN-	Length (Stations or Miles)		
		New Construction	Improvement	Renovation
14-7-2.2	16			0.88
14-7-3.0	16			0.66
14-7-3.1	16			0.58
14-7-3.2	16			0.85
14-7-4.1	16			0.98
14-7-4.1 Seg. B	16		0.08	
14-7-4.2	16			1.21
14-7-4.3	16			0.37
14-7-4.3 Seg. B	16		0.24	
14-7-5.0 Seg. A, C, & E	16			0.96
14-7-5.0 Seg. B & D	16		0.66	
14-7-5.1	16			0.50
14-7-5.6	16			0.68
14-7-10	16			0.15
P3	16	17+89		
P5	16	9+08		
P6	16	7+15		
P7	16	14+06		
P8	16	7+18		
P9	16	4+88		
P10	16	5+11		

GENERAL – 100

101 - Prewrite Conference(s):

A prework conference will be held prior to the start of renovation, improvement, new construction, surfacing, and mulching operations. The Purchaser shall request the conference at least 7 days prior to the time it is to be held. The conference will be attended by the Purchaser and/or his representative(s), subcontractor(s) and/or his or their representative(s) and the Authorized Officer and/or his representative(s).

The purpose will be to review the required work, exhibits and specifications, and to establish a work schedule and a list of the Purchaser's representatives and subcontractor(s).

102 - Definitions:

AASHTO - American Association of State Highway and Transportation Officials. Current editions of tests and specifications.

ASTM - American Society for Testing and Materials.

Base Course - Surfacing structure consisting of crushed gravel or stone, crushed sandstone, pit run rock, bank or river-run gravels, etc., to provide support and, in the event no surface course is placed, the running surface for traffic load.

BLM - Bureau of Land Management

Borrow - Excavated material required for embankments and other portions of the work.

Culvert - A pipe, pipe-arch, arch, or box structure constructed of metal, concrete, plastic or wood which provides an opening under the roadway primarily for the conveyance of liquids, pedestrians or livestock.

Curve Widening - Widening required on inside of curves to accommodate long log and equipment hauling trucks.

Embankment - A structure of soil, aggregate, or rock material placed on a prepared ground surface and constructed to subgrade.

End Haul - Excavated material moved, other than by dozer, to an embankment or waste area to prevent side casting material outside of the road prism.

GENERAL – 100

Excess Excavation - Material from the roadway in excess of that needed for construction of the designed roadway (waste).

Grading - Leveling to grade, shaping and smoothing of a road subgrade; the shaping of roadside ditches as to grade and contour. In some instances includes smoothing of the cut bank.

Overhaul - Distance excavated material is transported in excess of the distance included in the cost for excavation.

Pioneer Road - Temporary construction access built along the route of the project.

Piping - The process by which soil particles are washed in or through pore spaces in drains and filters or poorly compacted fill/backfill material.

Plans - The approved drawings, or exact reproductions thereof which show the locations, character, dimensions, and details of the work to be done.

Purchaser - The individual, partnership, joint venture, or corporation contracting with the Government under the terms of a Timber Sale Contract and acting independently or through their, or its agents, employees, or contractors.

Reasonably Close Conformity - Compliance with reasonable and customary manufacturing and construction tolerances where working tolerances are not specified.

Roadbed - The graded portion of the road within top and side slopes, prepared as a foundation for the pavement structure and shoulders.

Road Centerline - Longitudinal center of roadbed.

Road Improvement - Work done to an existing road which improves it over its original design standard.

Road Renovation - Work done to an existing road which restores it to its original design.

Roadway - The portion of a road within limits of construction. Usually from the toe of the fill slope to a point where the cut slope intersects natural ground line.  
Synonym - road prism.

GENERAL – 100

Scarification - The process of loosening or breaking up of the surface layer of soil or road, usually to a specified depth.

Shoulder - The portion of the roadbed contiguous with the traveled way designed for accommodation of stopped vehicles, safety, and lateral support of base and surface courses.

Slope Ratio – Slope ratio equals horizontal distance: vertical distance, HD:VD

Spalls - Flakes or chips of stone.

Specifications - A general term applied to all directions, provisions, and requirements pertaining to performance of the work.

Specific Gravity - The ratio of the density of a material to the density of water obtained by weighing known volumes of both items in air. A specific gravity less than one implies that the material will float.

Structures - Bridges, culverts, catch basins, retaining walls, underdrains, flumes, splash pads, downspouts, and other project features which may be involved in the work and not otherwise classified in these specifications.

Subbase - Reinforcement of the subgrade with large particles of pit run or crushed stone. Usually confined to roads having wet subgrades or subgrades with weak support characteristics.

Surface Course - Top layer of a road structure consisting of finely crushed gravels or asphalt designed to provide a smooth running surface for traffic load.

Subgrade - The top surface of a roadbed upon which the traveled way and shoulders are constructed.

Timber - Standing trees, downed trees, or logs which can be measured in board feet.

Traveled Way - The portion of the roadbed used for the movement of vehicles, exclusive of shoulders.

Typical Cross Sections - Cross-sectional plane of a typical roadway; showing natural ground line and designed roadway in relation to cut and fill, through cut, and through fill.

GENERAL – 100

Turnout - Extra widening of the roadbed at appropriate intervals on single-lane roads for passing purposes.

102a - Tests Used in These Specifications:

AASHTO T 11            Quantity of rock finer than No. 200 sieve.

AASHTO T 27            Sieve analysis of fine and coarse aggregate using sieves with square openings; gradation.

AASHTO T 96            Resistance to abrasion of small size coarse aggregate by use of the Los Angeles machine.  
This test required if requested by the Authorized Officer.

AASHTO T 99            Relationship between soil moisture and density of soil.  
                                  Method A - 4" mold, soil passing a No. 4 Sieve.  
                                  25 blows/layer & 3 layers.  
                                  Method C - 4" mold, soil passing a 3/4 inch sieve  
                                  25 blows/layer & 3 layers.  
                                  Method D - 6" mold, soil passing a 3/4 inches sieve.  
                                  56 blows/layer & 3 layers.  
This test required if requested by the Authorized Officer.

AASHTO T 210            Durability of aggregate based on resistance to produce fines.  
This test required if requested by the Authorized Officer.

103 - Compaction equipment shall meet the following requirements:

103a - Padded Drum (Tamping) Rollers. The unit shall consist of a drum with pads, be either self-propelled or towed by a tractor, and capable of operating at a speed of 6 mph. The drum shall be no less than 48 inches in diameter over the pads and not less than 60 inches in width. The pads shall have a minimum height of 3 inches, and a face area of not less than 14 square inches. The weight at drum shall be no less than 8000 lb.

GENERAL – 100

- 103b - (Sheepfoot) (Tamping) rollers. A tamping roller unit shall consist of two watertight metal drums mounted in frames in such manner as to be fully oscillating, together with a tractor having sufficient weight and power under actual working conditions to pull the roller drums at a minimum speed of 2.5 miles per hour. The drums shall be no less than 60 inches in diameter and no less than 54 inches in length, measured at the drum's surface, and shall be studded with tamping feet projecting not less than 7 inches from the face of the drums.

The distance between circumferential rows of tamper feet shall be such that the diagonal distance from any foot to the nearest foot in each adjacent row shall be not more than 12 inches. The cross-sectional area of the face of each tamper foot, measured perpendicular to the axis of the stud, shall be not less than 5-1/2 square inches nor more than 8 square inches.

The weight of the tamping-roller unit shall be such as to exert a minimum pressure of 250 pounds per square inch on the ground area in contact with the tamping feet, and the roller shall be so designed that the weight may be increased to exert a pressure up to 500 pounds per square inch on the ground area in contact with the tamping feet. The ground pressure shall be determined by dividing the total weight of the roller unit, not including the weight of the tractor, by the total cross-sectional area of the tamping feet in one row of tamping feet parallel to the axis of the roller.

- 103c - Smooth-wheel power rollers. Smooth-wheel power rollers shall either be of the 3-wheel type, weighing not less than 10 tons, or of the tandem type, 2-wheel or 3-wheel, weighing not less than 8 tons. Smooth-wheel roller shall provide compression of 325 pounds per linear inch of width of rear wheels or drum.

- 103e - Grid roller. A grid roller shall consist of two or more cylindrical drums independently mounted on a common shaft in a rigid frame. Each drum shall have a minimum outside diameter of 5 feet and a minimum width of 2 feet 6 inches. The overall width of the roller exclusive of frame shall be not less than 5 feet 6 inches of which not more than 6 inches shall be used for center spacing between two roller drums. The face of the drums shall have the appearance of woven open-mesh made by interlacing bars of not less than 1-1/4 inches nor more than 1-3/4 inches diameter space spaced on 4-1/2 inches to 5-1/2 inches center. Net opening between the bars shall be not less than 3 inches nor more than 4 inches. The roller shall be so constructed that counterweights can be used to adjust the gross weight of the roller to not less than 27,000 pounds. The grid roller shall be drawn by a power unit capable of propelling the fully loaded roller through 6 inches of loose embankment material at a speed of at least 4 miles per hour.

GENERAL – 100

- 103f - Vibratory roller. The drum diameter shall be not less than 48 inches, the drum width not less than 58 inches, and have a turning radius of 15 feet or less. Vibration frequency shall be regulated in steps to 1400, 1500, and 1600 vibrations per minute (VPM), corresponding to engine speeds of 1575, 1690, and 1800 RPM. The centrifugal force developed shall be 7 tons at 1600 RPM. It shall be activated by a power unit of not less than 25 horsepower. The vibratory roller shall be self-propelled or drawn by a vehicle of sufficient horsepower to enable the unit to travel through a loose layer of material at a speed ranging from 0.9 mile to 1.8 miles per hour, as directed by the Authorized Officer.

The towing vehicle and roller or self-propelled unit meeting the above requirements shall be considered a vibratory roller unit.

- 103g - Vibratory compactor. Vibratory compactors shall consist of multiple or gang-type compacting units or pads with a minimum variable width of 2 feet. It shall be self-contained and capable of compacting material as required.
- 103h - Drum drive self-propelled vibratory grid roller. The unit shall consist of one cylindrical drum with a drum diameter of not less than 56 inches, nor more than 66 inches and the drum width shall be 84 inches. Vibratory frequency shall be regulated in seeps from 1200 to 1800 vibrations per minute (VPM), and the centrifugal force developed shall be at least 40,000 pounds at 1800 RPM. The vibratory grid roller shall be self-propelled and have a power unit of not less than 112 horsepower. The "grid" design shall be a herringbone or z-bar pattern around the circumference of the drum. The grid bars shall be 1 inch in height and spaced not more than 8-1/2 inches apart.
- 103i - Other. Compaction equipment approved by the Authorized Officer.
- 105 - All project activities shall meet the following BMP requirements:
- 105a - All heavy equipment shall be cleaned prior to initially entering or operating on BLM lands. The equipment shall be free of noxious weed seed, external petroleum residue, caked on dirt or grime, and other contaminants. Any leakage or contamination risk shall be corrected prior to continuing operation. An inspection by the Authorized Officer is required prior to beginning work.
- 105b - No refueling of any heavy equipment shall be done within 100 feet of standing or running water.

GENERAL – 100

- 105c - The Purchaser and/or his representative(s), subcontractor(s) and/or his or their representative(s) shall comply with the following Sections of this contract in connection with any operations under this contract:
- Section 26 - Watershed Protection
  - Section 27 - Refuse Control and Disposal of Waste Materials
  - Section 28 - Storage and Handling of Hazardous Materials



U.S. DEPT. OF THE INTERIOR  
Bureau of Land Management  
NORTHWEST OREGON DISTRICT OFFICE - OREGON  
**150: ROAD PLAN AND DETAIL SHEET**

Sale Name Golden Nectar **EXHIBIT C**  
Contract No. ORNO2-15-2026.0203 Sheet 11 of 61

**150: ROAD PLAN AND DETAIL SHEET**

Road Number	From: Mile Post / STA	To: Mile Post / STA	Length (ft/mi)	Typical Section Type	Min Curve Radius	Road Width		Gradient		Clearing Width (ft)			Surfacing		Surface Course			REMARKS					
						Subgrade Width	Ditch Depth	Fav	Adv	Beyond		Minimum Width	Compact Depth	Surface Type	Grading Size	Number of Lifts	Minimum Width		Compact Depth	Surface Type	Grading Size	Number of Lifts	
										Top Cut	Toe Fill												Existing Roads (%)
P3	0+00	17+89	1789'	6	25%	16'	2'	-	-	-	-	15'	8"	PRR	-	2	14'	4"	ABC	A	1	Rock 3 Turn outs, 65 cu yd of 3" minus and Pit Run for landing	
P3	-	-	-	-	-	-	-	-	-	-	-	-	-	-	-	-	-	-	-	-	-	-	70 cu yd of 1 1/2" minus and 70 cu yd of 3/4" minus for culvert backfill and bedding
P5	0+00	9+08	908'	6	25%	16"	2'	-	-	-	-	15'	8"	PRR	-	2	14'	4"	ABC	A	1	Rock 1 Turn outs, 65 cu yd of 3" minus and Pit Run for landing	
P5	-	-	-	-	-	-	-	-	-	-	-	-	-	-	-	-	-	-	-	-	-	-	50 cu yd of 1 1/2" minus and 50 cu yd of 3/4" minus for culvert backfill and bedding
P6	0+00	7+15	715'	6	25%	16"	2'	-	-	-	-	15'	8"	PRR	-	2	14'	4"	ABC	A	1	Rock 1 Turn outs, 65 cu yd of 3" minus and Pit Run for landing	
P6	-	-	-	-	-	-	-	-	-	-	-	-	-	-	-	-	-	-	-	-	-	-	30 cu yd of 1 1/2" minus and 30 cu yd of 3/4" minus for culvert backfill and bedding
P7	0+00	14+06	1406'	6	25%	16'	2'	-	-	-	-	15'	8"	PRR	-	2	14'	4"	ABC	A	1	Rock 2 Turn outs, 65 cu yd of 3" minus and Pit Run for landing	
P7	-	-	-	-	-	-	-	-	-	-	-	-	-	-	-	-	-	-	-	-	-	-	60 cu yd of 1 1/2" minus and 60 cu yd of 3/4" minus for culvert backfill and bedding
P8	0+00	7+18	718'	6	25%	16'	2'	-	-	-	-	-	-	-	-	-	-	-	-	-	-	-	Rock 1 Turn outs, 65 cu yd of 3" minus and Pit Run for landing
P8	-	-	-	-	-	-	-	-	-	-	-	-	-	-	-	-	-	-	-	-	-	-	30 cu yd of 1 1/2" minus and 30 cu yd of 3/4" minus for culvert backfill and bedding
P9	0+00	4+88	488'	6	25%	16'	2'	-	-	-	-	15'	8"	PRR	-	2	14'	4"	ABC	A	1	Rock 1 Turn outs, 65 cu yd of 3" minus and Pit Run for landing	
P9	-	-	-	-	-	-	-	-	-	-	-	-	-	-	-	-	-	-	-	-	-	-	30 cu yd of 1 1/2" minus and 30 cu yd of 3/4" minus for culvert backfill and bedding
P9	-	-	-	-	-	-	-	-	-	-	-	-	-	-	-	-	-	-	-	-	-	-	Rock 1 Turn outs, 65 cu yd of 3" minus and Pit Run for landing
P10	-	-	-	-	-	-	-	-	-	-	-	15'	8"	PRR	-	2	14'	4"	ABC	A	1	Rock 1 Turn outs, 65 cu yd of 3" minus and Pit Run for landing	
P10	-	-	-	-	-	-	-	-	-	-	-	-	-	-	-	-	-	-	-	-	-	-	20 cu yd of 1 1/2" minus and 30 cu yd of 3/4" minus for culvert backfill and bedding

Note: Maintenance rock of 500 cy, meeting Sections 1000 AND 1200 specifications, shall be placed on haul route throughout the life of the timber sale. Not required for road acceptance under Section 18 of this contract.

**NOTES**

1. **Extra subgrade widths**  
Add to each shoulder: 1 foot for fills of 1 to 6 feet. Widen inside or outside shoulder of tight curves as needed for log trucks to maneuver, with tires remaining on roadbed.
2. **Backslopes**  
Materials: Solid rock 1/2:1  
Soft rock and shale 3/4:1  
Common  
Slopes under 55% 1:1  
Slopes over 55% 1-1/2:1  
Note: Full bench construction is required on side slopes exceeding 60%.  
Slope Ratio = Horizontal Distance:Vertical Distance (HD:VD)
3. **Surface Type**  
PRR - Pit run rock  
GRR - Grid rolled rock  
SRN - Screened rock  
JRR - Jaw run rock  
ABC - Aggr. base course  
ASC - Aggr. surface course  
WC - Wood chips
4. **Turnouts**  
Width shall be 10 feet in addition to the subgrade width, with lengths as shown on this plan, or as directed by the Authorized Officer.
5. **Surfacing**  
Turnouts, curve widening, and the first 50 feet of all road aprons shall be surfaced, for all road stations requiring surfacing, as listed above, and as directed by the Authorized Officer.
6. **Cleaning width** 200  
See Section \_\_\_\_\_
7. As posted and painted for Right-of-Way and as required in Section 2100 of this contract.
8. **Grading (Renovation)** 500  
See Section \_\_\_\_\_
9. **Drainage** 400  
See Section \_\_\_\_\_  
Culvert site aggregate, as designated in Section 400 of this contract, does not fulfill any requirements as listed above for full lifts of surface or base applications.
10. **Compaction** 300 and 500  
See Sections \_\_\_\_\_ and \_\_\_\_\_

NOTE: TYPE 1 through 4 TYPICAL SECTIONS not to be used where grade exceeds 6%

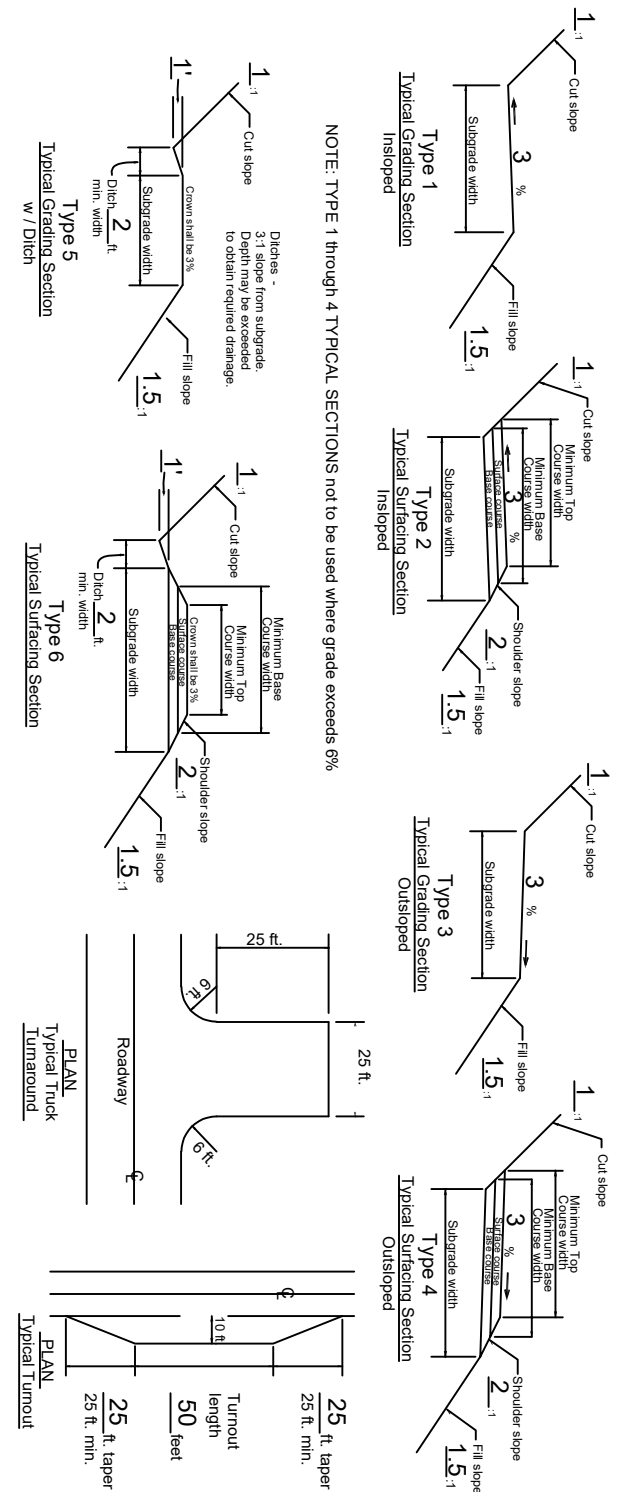

CLEARING AND GRUBBING - 200

- 201 - This work shall consist of clearing, grubbing, removing and disposing of vegetation, debris, surface objects, and protruding obstructions within the clearing limits in accordance with these specifications and conforming to the lines, grades, dimensions and typical cross sections shown on the plans and as staked on the ground.
- 202 - Where clearing limits have not been staked, established by these specifications or shown on the plans, the limits shall extend 10 feet back of the top of the cut slope and 5 feet out from the toe of the fill slope.
- 202a - Where clearing limits for structures have not been staked or shown on the plans, the limits shall extend 10 feet out from the outside edge of the structure.
- 203 - Clearing shall consist of the removal and disposal of trees, logs, rotten material, brush, and other vegetative materials and surface objects in accordance with these specifications and within the limits established for clearing as specified under Subsections 202, and 202a, as shown on the plans, and as staked on the ground and/or as posted.
- 203b - Standing trees and snags to be cleared shall be felled within the limits established for clearing unless otherwise authorized.
- 204 - Grubbing shall consist of the removal and disposal of stumps, roots, and other wood material embedded in the ground and protruding obstacles remaining as a result of the clearing operation and in accordance with Subsections 204a, and 204c between the top of the cut slope and the toe of the fill slope.
- 204a - Stumps, including those overhanging cut banks, shall be removed within the required excavation limits.
- 204c - On excavated areas, roots and embedded wood shall be removed to a depth not less than 6 inches below the subgrade.
- 205 - Clearing and grubbing debris shall not be placed or permitted to remain in or under road embankment sections.
- 210 - Disposal of clearing and grubbing debris shall be by scattering over government owned lands outside of established clearing limits in a manner acceptable to the Authorized Officer. The areas for such scattering shall have the prior approval of the Authorized Officer.

CLEARING AND GRUBBING - 200

- 210a - Disposal of clearing and grubbing debris shall be by piling on government lands outside of established clearing limits in an area and in a manner acceptable to the Authorized Officer, when accumulations are too great to scatter.
- 210b - Disposal of clearing and grubbing debris, stumps and cull logs on non-government property by scattering this material outside of clearing limits will not be permitted unless the Purchaser obtains a written permit, or other approved documentation, from the property owner on whose property the disposal is to be made. The Purchaser shall furnish the Authorized Officer a certified copy of the permit and a written release from the property owner absolving the Government from responsibilities in connection with the disposal of debris on said property.
- 212 - No grading will be permitted prior to completion and approval by the Authorized Officer of the required clearing and grubbing work, except that stump grubbing may proceed with the excavation of the road prism.
- 213 - No clearing or grubbing debris shall be left lodged against standing trees or otherwise impede tree felling on any trees within the existing stands adjacent to the road construction.
- 302a - The Purchaser is responsible for having all underground utilities located prior to any grubbing or excavation activities associated with culvert installation, ditch maintenance, or new road or skid trail construction adjacent to existing roads.

EXCAVATION AND EMBANKMENT - 300

- 301 - This work shall consist of excavating, overhaul, placement of embankments, backfilling, borrowing, leveling, ditching, grading, insloping, outsloping, crowning and scarification of the subgrade, compaction, disposal of excess and unsuitable materials, and other earth-moving work in accordance with these specifications and conforming to the lines, grades, dimensions, and typical cross sections shown on the plans.
- 302 - Excavation shall also consist of the excavation of road and landing cut sections, borrow sites, backfilling, leveling, ditching, grading, compaction, and other earth moving work necessary for the construction of the roadway in accordance with these specifications and conforming to the lines, grades, dimensions, and typical cross sections shown on the plans.

EXCAVATION AND EMBANKMENT – 300

- 303 - Suitable material removed from the excavation shall be used in the formation of embankment subgrade, shoulders, slopes, bedding, backfill for structures, and for other purposes as shown on the plans.
- 304 - Borrow shall consist of suitable material required for the construction of embankments or for other portions of the work; such material shall be obtained from sources selected by the Purchaser at his option and approved by the Authorized Officer.
- 305 - Embankment construction shall consist of the placement of excavated and borrowed materials, backfilling, leveling, grading, compaction, and other earth-moving work necessary for the construction of the roadway and landings in accordance with these specifications and conforming to the lines, grades, dimensions, and typical cross sections shown on the plans.
- 305a - Material used in the construction of embankment sections shall be free of stumps, cull logs, brush, muck, sod, roots, frozen material and other deleterious materials and shall be placed and compacted as specified.
- 305b - Embankment materials shall be placed in successive parallel layers on areas cleared of stumps, cull logs, brush, sod, and other vegetative and deleterious materials, except as provided under Subsection 204. Roadway embankments of earth material shall be placed in horizontal layers not exceeding 12 inches in depth.
- 306 - Layers of embankment, selected borrow, final subgrade, and selected roadway excavation material as specified under Subsections 305a, and 305b shall be moistened or dried to uniform optimum moisture content suitable for maximum density and compacted to full width with compacting equipment conforming to requirements of Subsections 103a, 103b, 103f, 103g and 103i.
- 306e - The final subgrade, including landings, shall be compacted to full width with of compacting equipment conforming to the requirements of Subsections 103f, 103g, and 103i. Minimum compaction shall be 1 hour of continuous compacting for each 4 stations of road or a fraction of as measured along the center line of the constructed road or until visible displacement ceases.
- 306f - Compaction of embankment layers placed as specified under Subsection 305b above shall be accomplished by routing construction equipment over full width of embankment structures (except as specified in Subsection 306).

EXCAVATION AND EMBANKMENT - 300

- 306g - All fill slopes shall be compacted to (75) percent of maximum density, either by walking with cat/excavator or by pressing with excavator bucket, to prevent surface erosion and raveling.
- 313 - In cut areas where solid rock is encountered at, or near subgrade, the rock shall be excavated to a minimum depth of 6 inches below subgrade elevation and the excavated area backfilled with suitable material. The backfill material shall be processed to the optimum moisture content suitable for maximum density and compacted to full width in accordance with the requirements of Subsection 306e.
- 314 - When heavy clays, muck, clay shale, or other deleterious material for forming the roadbed is encountered in cuts at subgrade, it shall be excavated to a minimum depth of 2 feet below the subgrade elevation and the excavated area backfilled with a selected borrow material approved by the Authorized Officer. The backfill material shall be uniformly moistened or dried to the optimum moisture content suitable for maximum density in accordance with the requirements of subsection 306. Unsuitable material shall be disposed of as directed by the Authorized Officer.
- 316 - Borrow material from sources selected at the Purchaser's option shall be inspected and approved in writing by the Authorized Officer prior to placement.
- 318 - Selected borrow or selected roadway excavation material shall be uniformly spread on the roadbed in lifts not to exceed 12 inches in depth until the required thickness shown on the plans is attained.

Each layer shall be uniformly moistened or dried to the optimum moisture content suitable for maximum density and compacted to full width in accordance with the requirements of Subsection 306.

- 320 - Ditches shall conform to the slope, grade, dimensions, and shape of the required cross section shown on the Section 150 sheet. Roots, stumps, rocks, and other projections shall be removed to form smooth, even slopes.
- 321 - Excess excavated, unsuitable, or slide materials shall not be disposed of on areas where the material will encroach on a stream course or other body of water. Such materials shall be disposed of in accordance with Subsection 321c.

EXCAVATION AND EMBANKMENT – 300

- 321c - End-dumping will be permitted for the placement of excess materials under Subsection 321 in designated disposal areas or within areas approved by the Authorized Officer. Watering, rolling, and placement in layers is required. Materials placed shall be sloped, shaped, and otherwise brought to a neat and slightly condition acceptable to the Authorized Officer. Exposed soils must be seeded and mulched in accordance with Section 1800 of this Contract.
- 324 - Excavated material shall not be allowed to cover boles of standing trees to a depth in excess of 1 foot on the uphill side.
- 327 - The finished grading shall be approved by the Authorized Officer in segments or for the total project. The Purchaser shall give the Authorized Officer 3 days notice prior to final inspection of the grading operations and start of surfacing operations.

PIPE CULVERTS - 400

- 401 - This work shall consist of furnishing and installing corrugated-polyethylene pipe culverts Type S (CPP) and other erosion control devices in accordance with these specifications and conforming to the lines, grades, dimensions, and typical cross sections shown on the plans. Individual lengths and locations are approximate; final lengths and locations will be determined by the Authorized Officer upon installation of the appurtenance structures. Additional pipe and erosion control devices may be required at the option of the Authorized Officer, in which case a reduction in the total purchase price shall be made to offset the cost of furnishing and installing such items. Costs will be based upon the unit prices set forth in the current BLM Timber Appraisal Production Cost Schedule.

PIPE CULVERTS – 400

402 - The culverts located at the following road locations:

Road No.	Sta./MP	Type	Remove	Diameter (inch)	Length (feet)	Surface Aggregate (cubic yard)	Remarks
14-7-3.0	0.45	CMP	24"x 40'	36	60	10 cys	--
14-7-3.1	0.35	CMP	24" x 35'	36	60	10 cys	Add 20' Downspout
	0.42	CMP	24" x 35'	36	60	10 cys	Add 20' Downspout
14-7-4.1 Seg. B	1+00	CPP	--	24	40	--	--
	2+50	CPP	--	24	40	--	--
14-7-4.3 Seg. B	2+00	CPP	--	24	40	--	--
	5+00	CPP	--	24	40	--	--
	7+00	CPP	--	24	40	--	--
	9+00	CPP	--	24	40	--	--
14-7-5.1 Seg. A-B	0.30	CPP	--	24	40	--	--
P3	0+50	CPP	--	24	40	--	--
	2+00	CPP	--	24	40	--	--
	4+50	CPP	--	24	40	--	--
	5+50	CPP	--	24	40	--	--
	7+50	CPP	--	24	40	--	--
	9+50	CPP	--	24	40	--	--
	12+50	CPP	--	24	40	--	--

PIPE CULVERTS – 400

Road No.	Sta./MP	Type	Remove	Diameter (inch)	Length (feet)	Surface Aggregate  (cubic yard)	Remarks
P5	0+50	CPP	--	24	40	--	--
	2+00	CPP	--	24	40	--	--
	4+50	CPP	--	24	40	--	--
	7+00	CPP	--	24	40	--	--
	8+50	CPP	--	24	40	--	--
P6	0+00	CPP	--	24	40	--	--
	3+00	CPP	--	24	40	--	--
	5+00	CPP	--	24	40	--	--
P7	1+00	CMP	--	24	40	--	--
	4+00	CMP	--	24	40	--	--
	7+00	CMP	--	24	40	--	--
	9+00	CMP	--	24	40	--	--
	11+00	CMP	--	24	40	--	--
	13+00	CMP	--	24	40	--	--
P9	0+00	CPP	--	24	40	--	--
	3+50	CPP	--	24	40	--	--
	5+00	CPP	--	24	40	--	--
P10	1+50	CPP	--	24	40	--	--
	3+00	CPP	--	24	40	--	--

Installation shall conform to the lines, grades, dimensions, and typical cross sections shown on the plans.

PIPE CULVERTS – 400

- 402a - The aggregate listed on the above tables shall meet the requirements of Section 1000 in conjunction with the specifications in Section 150, and shall be evenly distributed and compacted within the uppermost portion of the excavation limits. This material serves as a base rock and will not fulfill the obligation of surface rock required in Section 150. That rock shall still be placed on top of this base, at the required width and depth specified in Section 150.
- 402b - At culvert installation sites where riprap and surface aggregate currently exists, conserve the material for reuse as slope armor and for base material in the upper limits of the trench backfill.
- 403 - Grade culverts shall have a gradient of 2 percent to 4 percent greater than the adjacent road grade and shall be skewed down grade 30 degrees as measured from the perpendicular to the centerline unless otherwise specified on the plans or by the Authorized Officer.
- 405e - Corrugated-polyethylene pipe for culverts 18-inch through 36-inch diameter shall meet the requirements of AASHTO M 294, Type S, watertight joint.
- 406 - Coupling bands shall conform to the requirements of AASHTO M 36 and AASHTO M 218 or AASHTO M 274 with the exception of band widths and the "Hugger"-type band which shall conform to the details, dimensions, and typical diagram shown on the plans.
- 408 - Pipe culverts shall be placed on the bed starting at the downstream end with the inside circumferential laps pointing downstream and with the longitudinal laps at the side or quarter points. Coupling bands of the type required under these specifications shall be installed so as to provide the circumferential and longitudinal strength necessary to preserve the pipe alignment, prevent separation of the pipe sections, and minimize infiltration of fill material.
- 410 - Pipe shall be unloaded and handled with reasonable care. If the Authorized Officer determines any structure is damaged to the extent that it is unsuitable for use in the road construction, it shall be replaced at the Purchaser's expense.
- 411 - Trenches necessary for the installation of pipe culverts shall conform to the lines, grades, dimensions and typical diagram shown on the plans and the Culvert Installation Detail Sheets.

PIPE CULVERTS – 400

- 412 - Where ledge rock, boulders, soft, or spongy soils are encountered, they shall be excavated a minimum of 12 inches below the invert grade for a width of at least one pipe diameter or span on each side of the pipe and shall be backfilled with selected granular or fine readily compactible soil material.
- 413 - 24" pipe culverts and smaller shall be bedded on a fine readily compactible soil material having a depth of 6 inches, as shown on plans. Pipe culverts and pipe-arch culverts 30" and greater shall be bedded on a 1 ½" or ¾" crushed rock material in accordance with Section 1200 gradation. Each layer of crushed rock material for base shall be placed, processed, shaped, moistened or dried to uniform moisture content suitable for maximum compaction, and compacted to full width by compaction equipment conforming to the requirements of Subsection 103f and 103i. Foundation material shall be of uniform density throughout the length of the structure and shall be shaped to fit the pipe
- 416 - Side-fill material for pipe culverts shall be placed within 1 pipe diameter, or a minimum of 2 feet of the sides of the pipe barrel, and to 1 foot over the pipe with fine, readily compactible soil or granular fill material free of excess moisture, muck, frozen material, roots, sod, or other deleterious or caustic material and devoid of rocks or stones of sizes which may impinge upon and damage the pipe or otherwise interfere with proper compaction.
- 417 - Side-fill material conforming to the requirements of Subsection 416 shall be placed and compacted under the haunches of the pipe, and shall be brought up evenly and simultaneously on both sides of the pipe to 1 foot above the pipe, in layers not exceeding 8 inches in depth and 1 pipe diameter/span, or a minimum of 2 feet in width each side of, and adjacent to, the full length of the pipe barrel.
- 418 - Side fills beyond the compaction limits specified under Subsection 417 shall be compacted as specified under Section 300.
- 419 - The pipe culverts, after being bedded and backfilled as required by these specifications, shall be protected by a 2 foot cover of fill before heavy equipment is permitted to cross the drainage structures. Removal of the protection fill shall be as directed by the Authorized Officer.
- 423 - Construction of catch basins and ditch dams conforming to lines, grades, dimensions and typical diagrams shown on the plans, shall be required for grade culverts.

PIPE CULVERTS – 400

- 424 - Construction of splash pads conforming to lines, grades, dimensions and typical diagram shown in the plans, shall be required and at the specified locations and with riprap amounts as stated in the table in Subsection 401.
- 426 - Culvert markers consisting of 5 foot steel fence posts painted green with white tops, shall be furnished, fabricated, and installed by the Purchaser at the culvert inlets, as shown on the plans and as directed by the Authorized Officer.
- 427 - The Purchaser shall record culvert sizes, lengths and locations actually installed on a copy of the culvert list. This culvert list shall be furnished to the Authorized Officer
- 428 - Remove and dispose of old culverts in a legal manner, and for any fees required. The Purchaser shall remove the old culverts from the work site prior to road acceptance.

RENOVATION OF EXISTING ROADS - 500

- 501 - This work shall consist of reconditioning and preparing the roadbed and shoulders, minor excavation and/or embankment, cleaning and shaping drainage ditches, trimming vegetation from cut and embankment slopes, and cleaning and repairing drainage structures of existing roads in accordance with these specifications and as shown on the plans and as marked on the ground.
- 501a - This work shall include the removal and disposal of slides in accordance with these specifications.

RENOVATION OF EXISTING ROADS – 500

- 502 - The existing road surface shall be bladed and shaped to the lines, grades, dimensions, and typical cross sections shown on the plans at the following locations

Road No.	From Sta./M.P.	To Sta./M.P.
14-7-2.2	0.00	0.88
14-7-3.0	0.00	0.66
14-7-3.1	0.00	0.58
14-7-4.1	0.00	0.98
14-7-4.2	0.00	1.21
14-7-4.3	0.00	0.37
14-7-5.0	0.25	1.21
14-7-5.1	0.00	0.50
14-7-5.6	0.00	0.68
14-7-10	0.00	0.15

The existing road surface shall be scarified to its full width and to a minimum depth of 6 inches, as necessary to eliminate surface irregularities, prior to blading.

- 502a - Rocks larger than 6 inches in maximum dimension shall be removed from the scarified layers of the roadbed. Material so removed will not be permitted to remain on road shoulders or in ditches.
- 504 - Existing road surfaces shall be uniformly moistened or dried to the optimum moisture content suitable for maximum density and compacted to full width with equipment conforming to requirements of Subsections 103f, and 103i, until visible displacement ceases.

RENOVATION OF EXISTING ROADS – 500

- 506 - The inlet end of existing drainage structures shall be cleared of vegetative debris and boulders that are of sufficient size to obstruct normal stream flow. Pipe inverts shall be cleared of sediment and other debris lodged in the barrel of the pipe. The outflow area of pipe structures shall be cleared of rock and vegetative obstructions which will impede the structure's designed outflow configuration. Catch basins shall conform to the lines, grade, dimensions, and typical diagram shown on the plans.
- 508 - Vegetation encroaching on the roadbed and the drainage ditches of existing roads shall be removed by cutting and disposed of in accordance with Subsection 2100 of these specifications.
- 509 - The finished grading shall be approved by the Authorized Officer prior to surfacing operations. The Purchaser shall give the Authorized Officer 3 days notice prior to final inspection of the grading operations.

WATERING - 600

- 601 - This work shall consist of furnishing and applying water required for the compaction of embankments, roadbeds, backfills, base courses, surface courses, finishing and reconditioning of existing roadbeds, or for other uses in accordance with these specifications.
- 602 - Water, when needed for compaction or laying dust, shall be applied at the locations, in the amounts, and during the hours as directed by the Authorized Officer. Amounts of water to be provided will be the minimum needed to properly execute the compaction requirements in conformance with these specifications.
- 603 - Water trucks used in this work shall be equipped with a distributing device of ample capacity and of such design as to ensure uniform application of water on the road bed.
- 604 - Water required under these specifications is subject to applicable State water regulations.
- 605 - The Purchaser shall secure the necessary water permits for use of water source(s) selected by the Purchaser and approved by the Authorized Officer.

AGGREGATE BASE COURSE - 1000  
CRUSHED ROCK MATERIAL

- 1001 - This work shall consist of furnishing, hauling, and placing one or more lifts of crushed rock material on roadbeds, turnouts and landings approved for placing crushed rock material, in accordance with these specifications and conforming to the dimensions and typical cross sections shown on the Section 150 plans. Material not conforming to these specifications will be rejected, and shall be removed from the road.
- 1002a - Crushed rock materials may be obtained from commercial sources selected by the Purchaser at his option and expense providing that the rock materials selected comply with the specifications in this section.
- 1003 - Crushed rock material produced from gravel shall have 2 manufactured fractured faces on 65 percent, by weight, of the material retained on the No. 4 sieve.
- 1004 - Crushed rock materials shall consist of hard durable rock fragments conforming to the following gradation requirements:

TABLE 1004  
AGGREGATE BASE COURSE  
CRUSHED ROCK MATERIAL

Percentage by Weight Passing Square Mesh Sieves  
 (AASHTO T 11 & T 27)

GRADATION

Sieve Designation	A	B	C	D	F	G	H	I
(6) -inch	-	-	-	-	-	-	-	100
3-inch	100	-	100	-	100	-	-	45-65
2-inch	90-95	100	-	100	65-95	100	100	-
1 1/2-inch	-	90-95	-	-	-	-	-	-
1-inch	45-75	50-90	-	-	-	50-85	60-90	-
3/4-inch	-	-	-	-	28-70	-	-	-
1/2-inch	-	-	-	-	-	27-60	44-70	-
3/8-inch	-	-	-	-	-	-	-	-
No. 4	15-45	15-50	-	-	10-35	15-40	28-50	0-10
No. 8	-	-	-	-	-	-	20-41	-
No. 10	-	-	-	-	-	-	-	-
No. 30	-	-	-	-	5-22	8-26	9-26	-
No. 40	5-25	5-25	-	-	-	-	-	-
No. 200	2-15	2-15	-	-	3-10	3-12	3-12	-

1004a - The Purchaser shall be required to take 1 sample of each 2,000 cubic yards of crushed rock material produced, using approved AASHTO sampling procedures. The Purchaser shall submit samples to a certified lab or shall perform testing for gradation requirements using ASHTO T 11 and AASHTO T 27 testing procedures. Prior to testing, each sample shall be split, making one-half of the samples with proper identification available for testing by the Authorized Officer. Each sample and the results of Purchaser testing shall be made available to the Authorized Officer within 24 hours of sampling. The Purchaser shall provide test results for the first 500 cubic yards produced prior to commencing production crushing and hauling.

AGGREGATE BASE COURSE - 1000  
CRUSHED ROCK MATERIAL

- 1008 - If additional binder or filler is necessary in order to meet the grading or plasticity requirements, or for satisfactory bonding of the material, it shall be uniformly blended with the crushed rock material at the crushing and screening plant prior to placing on the road, unless otherwise agreed. The material for such purposes shall be obtained from sources approved by the Authorized Officer and shall be free from stones, vegetative matter, and other deleterious materials.
- 1008a - Each layer of crushed rock material shall be thoroughly mixed on the roadbed by alternately blading, to full depth, until a uniform mixture has been obtained. The mixture shall then be spread to full width. When completed, the spreading shall produce a surface which is smooth, presents uniform shoulder lines, and conforms to the specified cross section.
- 1009 - The roadbed, as shaped and compacted under Sections 300 and 500 of these specifications, shall be approved by the Authorized Officer prior to placement of crushed rock materials. Notification for final inspection prior to rocking shall be 72 hours prior to that inspection and shall be 7 days prior to start of rocking operations.
- 1010 - Crushed rock materials shall be placed and processed on the approved roadbed in accordance with these specifications and conforming to the lines, grades, dimensions, and typical cross sections shown on the plans, and compacted in layers not to exceed 8 inches in depth. When more than one layer is required, each shall be shaped, processed, compacted, and approved by the Authorized officer before the succeeding layer is placed. Irregularities or depressions that develop during compaction of the top layer shall be corrected by loosening the material at these places and adding or removing crushed rock material until the surface is smooth and uniform.
- 1010a - Crushed rock material used to repair or reinforce soft, muddy, frozen, yielding, or rutted roadbed shall not be construed as surfacing under this specification.
- 1012 - Each layer of crushed rock material for base shall be placed, processed, shaped, moistened or dried to uniform moisture content suitable for maximum compaction, and compacted to full width by compaction equipment conforming to the requirements of Subsection 103f and 103i. Minimum compaction shall be deemed adequate when the surface can withstand five passes of a truck, with H-20 loading without appreciable deformation.

AGGREGATE SURFACE COURSE - 1200  
CRUSHED ROCK MATERIAL

- 1201 - This work shall consist of furnishing, hauling, and placing one or more layers of crushed rock material on roadbeds and base courses approved for placing crushed rock material in accordance with these specifications and conforming to the dimensions and typical cross sections shown on the plans. Material not conforming to these specifications will be rejected and shall be removed from the road at the purchaser's expense.
- 1202a - Crushed rock materials used in this work may be obtained from commercial sources selected by the Purchaser at his option and expense, providing the rock materials furnished comply with the specifications.
- 1203 - When crushed rock material is produced from gravel, not less than 65 percent by weight of the particles retained on the No. 4 sieve will have 2 manufactured fractured faces. If necessary, to meet the above requirements or to eliminate an excess of filler, the gravel shall be screened before crushing.
- 1204 - Crushed rock material shall consist of hard durable rock fragments conforming to the following gradation requirements:

AGGREGATE SURFACE COURSE - 1200  
CRUSHED ROCK MATERIAL  
TABLE 1204

Percentage by weight passing square mesh sieves  
 AASHTO T 11 & T 27

GRADATION

Sieve Designation	C	C-1	D	D-1	E	E-1
1-1/2-inch	100	100	-	-	-	-
1-inch	-	-	100	100	-	-
3/4-inch	50-90	60-90	-	70-98	100	100
1/2-inch	-	-	-	-	-	70-98
No. 4	25-50	30-55	30-60	36-60	40-75	44-70
No. 8	-	22-43	-	25-47	-	30-54
No. 30	-	11-27	-	12-31	-	15-34
No. 40	5-25	-	5-30	-	5-35	-
No. 200	2-15	3-15	3-15	3-15	2-15	3-15

AGGREGATE SURFACE COURSE - 1200  
CRUSHED ROCK MATERIAL

- 1204a - The Purchaser shall be required to take one sample for each 1,000 cubic yards of crushed rock material to be utilized using AASHTO sampling procedures. The Purchaser shall submit samples to a certified lab or perform testing for gradation requirements using AASHTO T 11 and AASHTO T 27 testing procedures. Prior to testing, each sample shall be split, making one half of the sample, with proper identification, available for testing by the Authorized Officer. Each sample and the results of Purchaser testing shall be made available to the Authorized Officer within 24 hours of sampling. The Purchaser shall provide test results for the first 500 cubic yards produced prior to commencing production crushing and hauling.
- 1205 - Crushed rock material shall not exceed 35 percent loss as determined by AASHTO T 96.
- 1206 - Crushed rock material shall show a durability value of not less than 35 as determined by AASHTO T210.
- 1208 - If additional binder or filler material is necessary to meet the grading or plasticity requirements or for satisfactory bonding of the material, it shall be uniformly blended with the crushed rock material at the crushing and screening plant prior to placing on the road, unless otherwise agreed. The material for such purposes shall be obtained from sources approved by the Authorized Officer and shall be free from stones, vegetative matter, and other deleterious materials.
- 1208a - Each layer of crushed rock material shall be thoroughly mixed on the roadbed by alternately blading, to full depth, until a uniform mixture has been obtained. The mixture shall then be spread to full width. When completed, the spreading shall produce a surface which is smooth, presents uniform shoulder lines, and conforms to the specified cross section.
- 1209 - Shaping and compacting of roadbed and base course shall be completed and approved, prior to placing crushed rock material, in accordance to the requirements of Subsections 300 and 500 for placing on the roadbed and landings and Subsection 1000 for placing on the base course. Notification for final inspection prior to rocking shall be 7 days prior to the inspection and shall be 10 days prior to start of surfacing operations.

AGGREGATE SURFACE COURSE - 1200  
CRUSHED ROCK MATERIAL

- 1210 - Crushed rock material conforming to the requirements of these specifications shall be placed on the approved roadbed, landings, and base course in accordance with these specifications and conforming to the lines, grades, dimensions, and typical cross sections shown on the plans. Compacted layers shall not exceed 4 inches in depth. When more than one layer is required, each shall be shaped, processed, compacted, and approved by the Authorized Officer before the succeeding layer is placed. Irregularities or depressions that develop during compaction of the top layer shall be corrected by loosening the material at these places and then adding or removing crushed rock material until the surface is smooth and uniform.
- 1210a - Crushed rock material used to repair or reinforce soft, muddy, frozen, yielding, or rutted roadbed shall not be construed, as surfacing required by this specification.
- 1212 - Each layer of crushed rock material placed, processed, and shaped as specified shall be moistened or dried to a uniform moisture content suitable for maximum compaction and compacted to full width by compacting equipment conforming to the requirements of Subsection 103f and 103i. Minimum compaction shall be 1 hour of continuous compacting for each 6 stations, or fraction thereof.

EROSION CONTROL - 1700

- 1701 - This work shall consist of measures to control soil erosion or water pollution during the construction operation through the use of berms, dikes, dams, sediment basins, fiber mats, netting, gravel, mulches, grasses, slope drains and other erosion control devices or methods in accordance with these specifications and conforming to the lines, grades, dimensions and typical cross sections shown on the plans.
- 1704 - The erosion control provisions specified under this Subsection shall be coordinated with the Soil Stabilization requirements of section 1800.
- 1705 - The surface area of erodible earth material exposed at any one time by clearing and grubbing shall not exceed 4000 square feet after September 15, without prior approval by the Authorized Officer.
- 1706 - The surface area of erodible earth material exposed at one time by excavation, borrow, or fill within the right-of-way shall not exceed 4000 square feet after September 15, without prior approval by the Authorized Officer.

EROSION CONTROL - 1700

- 1707 - Completed and partially completed segments of roads carried over the winter and early spring periods shall be stabilized by seeding, fertilizing, and mulching in accordance with Section 1800.
- 1708 - Newly constructed (or graded) roads to be carried over the winter period, shall be blocked to vehicular traffic.
- 1708a - Road segments not completed during dry weather periods shall be winterized, by providing a well-drained roadway using water bars, maintaining drainage, and performing additional measures necessary to minimize erosion and other damage to the roadway, as directed by the Authorized Officer. Portions of roads not having surface rock in place will be blocked or barricaded to prevent vehicular traffic.
- 1712 - The Purchaser shall provide erosion control measures for reconstructed ditches on steep grades which includes but is not limited to, dumped stone, jute mesh, sod, or check dams consisting of stone. Width of protective lining or dam should extend far enough up the ditch slopes to effectively contain the runoff and prevent erosion and washout at the edges and prevent sediment from reaching live water.

SOIL STABILIZATION - 1800

- 1801 - This work shall consist of seeding and mulching on designated cuts, fills, borrow sites, disposal sites, special areas, and any other disturbed areas in accordance with these specifications and as shown on the plans. This work is required for road acceptance under Section 18 of this contract.

SOIL STABILIZATION - 1800

- 1802 - Soil stabilization work consisting of seeding, fertilizing, and mulching shall be performed on existing roads and designated locations in accordance with these specifications, at the following locations:

Road No.	From Sta./M.P.	To Sta./M.P.
14-7-2.2	0.00	0.88
14-7-3.0	0.00	0.66
14-7-3.1	0.00	0.58
14-7-3.2	0.00	0.85
14-7-4.1	0.00	1.06
14-7-4.2	0.00	1.21
14-7-4.3	0.00	0.61
14-7-5.0	0.25	1.87
14-7-5.1	0.00	0.50
14-7-5.6	0.00	0.68
14-7-10	0.00	0.15
P3	0+00	17+89
P5	0+00	9+08
P6	0+00	7+15
P7	0+00	14+06
P8	0+00	7+18
P9	0+00	4+88
P10	0+00	5+11

SOIL STABILIZATION - 1800

- 1803 - Soil stabilization work as specified under Subsections 1802 shall be performed during the following seasonal periods:

From: April 15	To: May 15
From: September 30	To: October 31

The Authorized Officer may modify the above seasonal dates to conform to existing weather conditions and changes in the construction schedule.

- 1804 - The Purchaser shall furnish the following species of grass seed meeting corresponding germination, purity, and weed-content requirements:

Species	Germination Min. %	Purity Min. %	Crop and Weed Content Max. %	Noxious Weed Content Max %
Red Fescue	85%	97%	0%	0%

Furnished seed shall meet or exceed the factors in the above table. Furnished seed shall be sown at a rate equal to 10 pounds per acre. Prior to applying seed, the contractor will supply the BLM with the seed label showing testing results.

If seed is not available that meets the factors in the above table, the project area would be sown with seed approved by the resource area botanist. Prior to applying seed, the contractor will supply the BLM with the seed label showing testing results.

- 1806a - Additional soil stabilization work consisting of seeding, fertilizing, and mulching, may be required at the option of the Authorized Officer. Providing the additional stabilization is not due to Purchaser negligence as specified in Sec. 12 of the contract, a reduction in the total purchased price shall be made to offset the cost of furnishing and applying such additional stabilization material. Cost shall be based upon the unit price set forth in the current BLM Timber Appraisal Production Cost Schedule.

- 1807 - Fertilizer shall be a standard commercial grade of fertilizer conforming (to all State and Federal regulations. Fertilizer furnished shall provide the minimum percentage of available nutrients as specified below:

Available nitrogen	(16) %
Available phosphoric acid	(20) %
Potassium	(0) %

SOIL STABILIZATION – 1800

- 1808 - Mulch materials conforming to the requirements of Subsections 1808a shall be furnished by the Purchaser and applied in accordance with Subsection 1812.
- 1808a - Straw mulch shall be certified weed free from commercial grain fields and native grass fields. Straw mulch shall be from oats, wheat, rye, or other approved grain crops which are free from mold, or other objectionable materials. Straw mulch shall be in an air-dry condition and suitable for placement.
- 1809 - Mulch material shall be delivered to the work area in a dry state. Material found to be wet will not be accepted. Material to be used in the mulching operation may be stockpiled along the road designated for treatment provided that it is maintained in a dry state and has the approval of the Authorized Officer.
- 1810 - Bulk mulching material required under these specifications shall be delivered to the work area bound either by twine, string or hemp rope. Wire binding will not be permitted.
- 1812 - The Purchaser shall furnish and apply to the area designated for treatment as shown on the plans, a mixture of grass seed, fertilizer, and mulch material at the application rate to be determined by the Authorized Officer based on visual observation of trial applications.
- 1814 - The Purchaser may reduce the application rate on partially covered slopes and refrain from application on areas already well stocked with grass, or on rock surfaces, as determined by the Authorized Officer.
- 1815 - The seed and mulch materials shall be placed by the dry method in accordance with the requirements set forth in Subsection 1815b.
- 1815b - Dry Method - Blowers, mechanical seeders, seed drills, landscape seeders, cultipaker seeders, fertilizer spreaders or other approved mechanical seeding equipment may be used when seed and fertilizer are to be applied in dry form.
- 1817 - At the beginning of each day's operation, a measured area will be seeded and mulched to assure uniform application.
- 1819 - The Purchaser shall notify the Authorized Officer at least 3 days in advance of date he intends to commence the specified soil stabilization work.

SOIL STABILIZATION – 1800

- 1821 - Mulch that collects at the end of culverts or accumulates to excessive depths on the slopes shall be evenly spread by hand methods, as directed by the Authorized Officer.
- 1824 - Twine, rope, sacks, and other debris resulting from the soil-stabilization operation shall be picked up and disposed of to the satisfaction of the Authorized Officer.

ROADSIDE BRUSHING – 2100

- 2101 - This work shall consist of the removal of vegetation from the road prism - variable distance, and inside curves in accordance with these specifications and conforming to the lines, grades, dimensions, and typical cross sections shown on the Roadside Brushing Detail Sheet of this exhibit, at designated locations as shown in the plans.
- 2102 - Roadside brushing may be performed mechanically with self-powered, self-propelled equipment or manually with hand tools, including chain saws.
- 2103 - Vegetation, cut manually or mechanically, less than 6 inches in diameter at D.B.H.O.B., shall be cut to a maximum height of 2 inches above the ground surface or above obstructions such as rocks or stumps, on cut and fill slopes. All limbs below the 2 inch area will be severed from the trunk.
- 2103a - Vegetation shall be cut and removed from the roadbed between the outside shoulders and the ditch centerline and such vegetation shall be cut to a maximum height of 1 inch above the ground and running surface. Limbs below the 1 inch area will be severed from the trunk. Sharp pointed ends will not be permitted. Cuts shall be parallel to the ground line or running surface.
- 2104 - Trees in excess of 6 inches in diameter at D.B.H.O.B. shall be limbed, so that no limbs extend into the treated area or over the roadbed to a height of 14 feet above the running surface of the roadway on cut and fill slopes, within the road prism-variable distance. Limbs shall be cut to within 1 inch of the trunk to produce a smooth vertical face. Removal of trees larger than 6 inches in diameter for sight distance or safety may be directed by the Authorized Officer.
- 2105 - Vegetation that is outside of the road prism-variable distance that protrudes into the road prism and within 14 feet in elevation above the running surface shall be cut, to within 1 inch of the trunk to produce a smooth vertical face.

ROADSIDE BRUSHING – 2100

- 2106 - Vegetative growth capable of growing 1 foot in height or higher shall be cut, within the road prism-variable distance or as directed by the Authorized Officer.
- 2107 - Inside curves shall be brushed out for a sight distance of 200 feet chord distance or a middle ordinate distance of 25 feet whichever is achieved first. Overhanging limbs and vegetation in excess of 1 foot in height shall be cut within these areas.
- 2108 - Self-propelled equipment shall not be permitted on cut and fill slopes or in ditches.
- 2109 - Debris resulting from this operation shall be scattered downslope from the roadway. Debris shall not be allowed to accumulate in concentrations. Debris in excess of 1 foot in length and 2 inches in diameter shall not be allowed to remain on cut slopes, ditches, roadways or water courses, or as directed by the Authorized Officer.
- 2113 - Roadside brushing shall be completed before timber haul.
- 2115 - Mechanical brush cutters shall not be operated when there are people and occupied vehicles within 400 feet of the immediate operating area.
- 2116 - Traffic warning signs shall be required at each end of the work area. Signs shall meet the requirements of the Manual on Uniform Traffic Control Devices.

ROAD DECOMMISSIONING – 2700

- 2701 - This work consists of decommissioning the following roads:

Road No.	From Sta./M.P.	To Sta./M.P.
P3	0+00	17+89
P5	0+00	9+08
P6	0+00	7+15
P7	0+00	14+06
P8	0+00	7+18
P9	0+00	4+88
P10	0+00	5+11

This work is not required for road acceptance under Section 18 of this contract.

ROAD DECOMMISSIONING – 2700

- 2702 - Decommissioning may consist of removing cross drain culverts, installing water bars, placement of soil stabilization material, de-compacting, and blocking road from access by vehicles. Decommissioning shall be directed by Authorized Officer. This work is not required for road acceptance under Section 18 of this contract.
- 2703 - Where windrows, berms, or vegetation exist along the outside shoulder of the decommissioned roadbed, they shall be removed to promote drainage. Outlet channels will be constructed at as frequent of locations as possible where trees interfere with drainage.
- 2704 - Water bars shall be installed on the road listed in Subsection 2701, at the following intervals:

Road Gradient	Spacing Distance
0 - 5%	400 feet
6 - 12%	300 feet
13% and greater	200 feet

at locations approved by the Authorized Officer, and in accordance with these specifications and conforming to the lines, grades, dimensions, and typical cross sections shown on the plans, skipping locations that are at high points.

- 2706 - Soil stabilization work consisting of seeding and mulching shall be performed as specified under Section 1800, in areas left exposed as a result of logging, final road maintenance, or decommissioning operations.

ROAD CONSTRUCTION WORKLIST

Work to be Accomplished

Road construction operations as required under Exhibit C of this contract shall include but is not limited to the following worklist. All existing roads shall be brushed, shall be graded and compacted to their full width, shall have the ditches cleared of any blockages, and shall have existing culverts and catch basins cleaned at locations that are not listed in Section 400 for replacement. Any soils left exposed after renovation or new construction activities shall be seeded and mulched. Roadside tree removal shall be accomplished prior to culvert installations and aggregate placement. Roadside trees shall not be felled onto existing roads. Processing shall not be accomplished on top of existing aggregate surfaces. Logging slash and log decks shall not be placed in ditches, in catch basins, or on top of culvert outlets.

Road No. 14-7-2.2

MP

- 0.00 - Begin Renovation. Begin brushing as described in Section 2100, renovation work as described in Sections 150 and 500, and rocking application as described in Sections 150 and 1200. Road prism should resemble the Typical Section Type as described in Section 150 upon completion of work. Soil stabilization and erosion control measures will be required as described in Sections 1700 and 1800.
- 0.16 - Install 6" lift for 100' each side of stream crossing using 3" open aggregate. Install straw wattles in areas that will filter road run off effectively as needed or directed by Authorized Officer.
- 0.26 - End road renovation.

Road No. 14-7-3.0 Seg. A and B

MP

- 0.00 - Begin Renovation. Begin brushing as described in Section 2100, renovation work as described in Sections 150 and 500, and rocking application as described in Sections 150 and 1200. Road prism should resemble the Typical Section Type as described in Section 150 upon completion of work. Soil stabilization and erosion control measures will be required as described in Sections 1700 and 1800.

- 0.01 - Install 6" lift for 100' each side of stream crossing using 3" open aggregate. Install straw wattles in areas that will filter road run off effectively as needed or directed by Authorized Officer.
- 0.26 - End road renovation.

Road No. 14-7-3.0 Seg. C and D

MP

- 0.26 - Begin Renovation. Begin brushing as described in Section 2100, renovation work as described in Sections 150 and 500, install culverts as described in Sections 400, and rocking application as described in Sections 150 and 1200. Road prism should resemble the Typical Section Type as described in Section 150 upon completion of work. Soil stabilization and erosion control measures will be required as described in Sections 1700 and 1800.
- 0.35 - Install 6" lift for 100' each side of stream crossing using 3" open aggregate. Install straw wattles in areas that will filter road run off effectively.
- 0.45 - Replace 24"x 40' CMP with 36"x 60' CMP culvert. Install culvert as described in Section 400. Install 6" lift for 100' each side of stream crossing using 3" open aggregate. Install straw wattles in areas that will filter road run off effectively.
- 0.66 - End road renovation.

Road No. 14-7-3.1 Seg. A Part

MP

- 0.00 - Begin Renovation. Begin brushing as described in Section 2100, renovation work as described in Sections 150 and 500, install culverts as described in Sections 400, and rocking application as described in Sections 150 and 1200. Road prism should resemble the Typical Section Type as described in Section 150 upon completion of work. Soil stabilization and erosion control measures will be required as described in Sections 1700 and 1800.
- 0.16 - Install 6" lift for 100' each side of stream crossing using 3" open aggregate. Install straw wattles in areas that will filter road run off effectively as needed or directed by Authorized Officer.

ROAD CONSTRUCTION WORKLIST

- 0.28 - Install 6" lift for 100' each side of stream crossing using 3" open aggregate. Install straw wattles in areas that will filter road run off effectively as needed or directed by Authorized Officer.

Road No. 14-7-3.1 Seg. A Part

MP

- 0.35 - Replace 24"x 40' CMP with 36"x 60' CMP culvert. Install culvert as described in Section 400.
- 0.42 - Replace 24"x 40' CMP with 36"x 60' CMP culvert. Install culvert as described in Section 400. Install 6" lift for 100' each side of stream crossing using 3" open aggregate. Install straw wattles in areas that will filter road run off effectively as needed or directed by Authorized Officer.
- 0.58 - End road renovation.

Road No. 14-7-3.2

MP

- 0.00 - Begin Renovation. Begin brushing as described in Section 2100, renovation work as described in Sections 150 and 500, and rocking application as described in Sections 150 and 1200. Road prism should resemble the Typical Section Type as described in Section 150 upon completion of work. Soil stabilization and erosion control measures will be required as described in Sections 1700 and 1800.
- 0.03 - Install 6" lift for 100' each side of stream crossing using 3" open aggregate. Install straw wattles in areas that will filter road run off effectively as needed or directed by Authorized Officer.
- 0.08 - Install 6" lift for 100' each side of stream crossing using 3" open aggregate. Install straw wattles in areas that will filter road run off effectively as needed or directed by Authorized Officer.

ROAD CONSTRUCTION WORKLIST

- 0.29 - Install 6" lift for 100' each side of stream crossing using 3" open aggregate. Install straw wattles in areas that will filter road run off effectively as needed or directed by Authorized Officer.
- 0.44 - Install 6" lift for 100' each side of stream crossing using 3" open aggregate. Install straw wattles in areas that will filter road run off effectively as needed or directed by Authorized Officer.

Road No. 14-7-3.2

MP

- 0.59 - Install 6" lift for 100' each side of stream crossing using 3" open aggregate. Install straw wattles in areas that will filter road run off effectively as needed or directed by Authorized Officer.
- 0.85 - End road renovation.

Road No. 14-7-4.1 Seg. A

MP

- 0.00 - Begin Renovation. Begin brushing as described in Section 2100, renovation work as described in Sections 150 and 500, and rocking application as described in Sections 150 and 1200. Road prism should resemble the Typical Section Type as described in Section 150 upon completion of work. Soil stabilization and erosion control measures will be required as described in Sections 1700 and 1800.
- 0.24 - Install 6" lift for 100' each side of stream crossing using 3" open aggregate. Install straw wattles in areas that will filter road run off effectively as needed or directed by Authorized Officer.
- 0.29 - Install 6" lift for 100' each side of stream crossing using 3" open aggregate. Install straw wattles in areas that will filter road run off effectively as needed or directed by Authorized Officer.

ROAD CONSTRUCTION WORKLIST

- 0.46 - Install 6" lift for 100' each side of stream crossing using 3" open aggregate. Install straw wattles in areas that will filter road run off effectively as needed or directed by Authorized Officer.
- 0.61 - Install 6" lift for 100' each side of stream crossing using 3" open aggregate. Install straw wattles in areas that will filter road run off effectively as needed or directed by Authorized Officer.

Road No. 14-7-4.1 Seg. A

MP

- 0.70 - Install 6" lift for 100' each side of stream crossing using 3" open aggregate. Install straw wattles in areas that will filter road run off effectively as needed or directed by Authorized Officer.
- 0.84 - Install 6" lift for 100' each side of stream crossing using 3" open aggregate. Install straw wattles in areas that will filter road run off effectively as needed or directed by Authorized Officer.
- 0.90 - Install 6" lift for 100' each side of stream crossing using 3" open aggregate. Install straw wattles in areas that will filter road run off effectively as needed or directed by Authorized Officer.
- 0.94 - Install 6" lift for 100' each side of stream crossing using 3" open aggregate. Install straw wattles in areas that will filter road run off effectively as needed or directed by Authorized Officer.
- 0.97 - Install 6" lift for 100' each side of stream crossing using 3" open aggregate. Install straw wattles in areas that will filter road run off effectively as needed or directed by Authorized Officer.
- 0.98 - End road renovation.

ROAD CONSTRUCTION WORKLIST

Road No. 14-7-4.1 Seg. B

MP

- 0.00 - Begin improvement. Begin clearing and grubbing as described in Section 200 within the posted ROW limits. Begin excavation and embankment as described in Section 300 as necessary to meet the typical roadbed shown in Section 150, install culverts as described in Sections 400, and begin rock applications as described in Sections 150, 1000, and 1200, and Soil stabilization and erosion control measures will be required as described in Sections 1700 and 1800.

Road No. 14-7-4.1 Seg. B

MP

- 0.02 - Install 24"x 40' CPP cross drain. Install culvert as described in Section 400. Station is an estimate after roadbed has been roughed in Authorized Officer and Road Builder will place culverts in best position.
- 0.05 - Install 24"x 40' CPP cross drain. Install culvert as described in Section 400. Station is an estimate after roadbed has been roughed in Authorized Officer and Road Builder will place culverts in best position.
- 0.08 - End road renovation.

Road No. 14-7-4.2

MP

- 0.00 - Begin Renovation. Begin brushing as described in Section 2100 and renovation work as described in Sections 150 and 500. Road prism should resemble the Typical Section Type as described in Section 150 upon completion of work. Soil stabilization and erosion control measures will be required as described in Sections 1700 and 1800.
- 1.21 - End road renovation.

ROAD CONSTRUCTION WORKLIST

Road No. 14-7-4.3 Seg. A

MP

- 0.00 - Begin Renovation. Begin brushing as described in Section 2100, renovation work as described in Sections 150 and 500, and rocking application as described in Sections 150 and 1200. Road prism should resemble the Typical Section Type as described in Section 150 upon completion of work. Soil stabilization and erosion control measures will be required as described in Sections 1700 and 1800.

Road No. 14-7-4.3 Seg. A

MP

- 0.21 Install 6" lift for 100' each side of stream crossing using 3" open aggregate. Install straw wattles in areas that will filter road run off effectively as needed or directed by Authorized Officer.
- 0.32 - Install 6" lift for 100' each side of stream crossing using 3" open aggregate. Install straw wattles in areas that will filter road run off effectively as needed or directed by Authorized Officer.
- 0.37 - End road renovation.

Road No. 14-7-4.3 Seg. B

MP

- 0.37 - Begin improvement. Begin clearing and grubbing as described in Section 200 within the posted ROW limits. Begin excavation and embankment as described in Section 300 as necessary to meet the typical roadbed shown in Section 150, install culverts as described in Sections 400, and begin rocking applications as described in Sections 150, 1000, and 1200, and Soil stabilization and erosion control measures will be required as described in Sections 1700 and 1800.
- 0.40 - Install 24"x 40' CPP cross drain. Install culvert as described in Section 400. Station is an estimate after roadbed has been roughed in Authorized Officer and Road Builder will place culverts in best position.

ROAD CONSTRUCTION WORKLIST

- 0.46 - Install 24"x 40' CPP cross drain. Install culvert as described in Section 400. Station is an estimate after roadbed has been roughed in Authorized Officer and Road Builder will place culverts in best position.

Road No. 14-7-4.3 Seg. B

MP

- 0.50 - Install 24"x 40' CPP cross drain. Install culvert as described in Section 400. Station is an estimate after roadbed has been roughed in Authorized Officer and Road Builder will place culverts in best position.
- 0.54 - Install 24"x 40' CPP cross drain. Install culvert as described in Section 400. Station is an estimate after roadbed has been roughed in Authorized Officer and Road Builder will place culverts in best position.
- 0.61 - End road improvement.

Road No. 14-7-5.0

MP

- 0.24 - Segment A part of 14-7-5.0. Begin renovation. Begin brushing as described in Section 2100, renovation work as described in Sections 150 and 500, and rocking application as described in Sections 150 and 1200. Road prism should resemble the Typical Section Type as described in Section 150 upon completion of work. Soil stabilization and erosion control measures will be required as described in Sections 1700 and 1800.
- 0.36 - End renovation.
- 1.55 - Begin renovation. Begin clearing and grubbing as described in Section 200. Begin excavation and embankment as described in Section 300 as necessary to meet the typical roadbed shown in Section 150, begin rocking applications as described in Sections 150, 1000, and 1200, and Soil stabilization and erosion control measures will be required as described in Sections 1700 and 1800.
- 1.57 - Begin slide repair on Weyerhaeuser. Excavate into the cut bank, haul access material to the intersection of 14-7-10.0 and P5. Use access material to help build the 10.0 road and P5 tie in.

ROAD CONSTRUCTION WORKLIST

1.58 - End slide repair.

Road No. 14-7-5.0

MP

- 1.90 - Begin Segment B of 14-7-5.0. End renovation and begin improvement. Begin clearing and grubbing as described in Section 200. Begin excavation and embankment as described in Section 300 as necessary to meet the typical roadbed shown in Section 150, install culverts as described in Sections 400, and begin rocking applications as described in Sections 150, 1000, and 1200, and Soil stabilization and erosion control measures will be required as described in Sections 1700 and 1800.
- 2.08 - Begin Segment C of 14-7-5.0. End improvement and begin renovation. Begin brushing as described in Section 2100, renovation work as described in Sections 150 and 500, and rocking application as described in Sections 150 and 1200. Road prism should resemble the Typical Section Type as described in Section 150 upon completion of work. Soil stabilization and erosion control measures will be required as described in Sections 1700 and 1800.
- 2.72 - Begin Segment D of 14-7-5.0. End renovation and begin improvement. Begin clearing and grubbing as described in Section 200. Begin excavation and embankment as described in Section 300 as necessary to meet the typical roadbed shown in Section 150, install culverts as described in Sections 400, and begin rocking applications as described in Sections 150, 1000, and 1200, and Soil stabilization and erosion control measures will be required as described in Sections 1700 and 1800.
- 3.28 - Begin Segment E of 14-7-5.0. End improvement and begin renovation. Begin brushing as described in Section 2100, renovation work as described in Sections 150 and 500, and rocking application as described in Sections 150 and 1200. Road prism should resemble the Typical Section Type as described in Section 150 upon completion of work. Soil stabilization and erosion control measures will be required as described in Sections 1700 and 1800.
- 3.68 - End renovation.

ROAD CONSTRUCTION WORKLIST

Road No. 14-7-5.1

MP

- 0.00 - Begin Renovation. Begin brushing as described in Section 2100, renovation work as described in Sections 150 and 500, install culverts as described in Sections 400, and rocking application as described in Sections 150 and 1200. Road prism should resemble the Typical Section Type as described in Section 150 upon completion of work. Soil stabilization and erosion control measures will be required as described in Sections 1700 and 1800.
- 0.05 - Install 6" lift for 100' each side of stream crossing using 3" open aggregate. Install straw wattles in areas that will filter road run off effectively as needed or directed by Authorized Officer.
- 0.30 - Replace 18"x 30' CMP with 24"x 40' CMP culvert. Install culvert as described in Section 400.
- 0.50 - End renovation.

Road No. 14-7-5.6

MP

- 0.00 - Begin Renovation. Begin brushing as described in Section 2100, renovation work as described in Sections 150 and 500, and rocking application as described in Sections 150 and 1200. Road prism should resemble the Typical Section Type as described in Section 150 upon completion of work. Soil stabilization and erosion control measures will be required as described in Sections 1700 and 1800.
- 0.21 - Install 6" lift for 100' each side of stream crossing using 3" open aggregate. Install straw wattles in areas that will filter road run off effectively as needed or directed by Authorized Officer.
- 0.38 - Install 6" lift for 100' each side of stream crossing using 3" open aggregate. Install straw wattles in areas that will filter road run off effectively as needed or directed by Authorized Officer.
- 0.68 - End renovation.

ROAD CONSTRUCTION WORKLIST

Road No. 14-7-10.0

MP

- 0.00 - Begin renovation. Begin clearing and grubbing as described in Section 200. Begin excavation and embankment as described in Section 300 as necessary to meet the typical roadbed shown in Section 150, begin rocking applications as described in Sections 150, 1000, and 1200, and Soil stabilization and erosion control measures will be required as described in Sections 1700 and 1800. Use excess material from the 14-7-5.0 road repair to blend the 14-7-10 road and P5 intersection.
- 0.15 - End renovation.

Road No. P3

Sta.

- 0+00 - Begin new construction. Begin clearing and grubbing as described in Section 200 within the posted ROW limits. Begin excavation and embankment as described in Section 300 as necessary to meet the roadbed typical shown in Section 150, install culverts as described in Sections 400, begin rocking applications as described in Sections 150, 1000, and 1200, and Soil stabilization and erosion control measures will be required as described in Sections 1700 and 1800.
- 0+50 - Install 24"x 40' CPP cross drain. Install culvert as described in Section 400. Station is an estimate after roadbed has been roughed in Authorized Officer and Road Builder will place culverts in best position.
- 2+00 - Install 24"x 40' CPP cross drain. Install culvert as described in Section 400. Station is an estimate after roadbed has been roughed in Authorized Officer and Road Builder will place culverts in best position.
- 4+50 - Install 24"x 40' CPP cross drain. Install culvert as described in Section 400. Station is an estimate after roadbed has been roughed in Authorized Officer and Road Builder will place culverts in best position.
- 5+50 - Install 24"x 40' CPP cross drain. Install culvert as described in Section 400. Station is an estimate after roadbed has been roughed in Authorized Officer and Road Builder will place culverts in best position.

ROAD CONSTRUCTION WORKLIST

Road No. P3

Sta.

- 7+50 - Install 24"x 40' CPP cross drain. Install culvert as described in Section 400. Station is an estimate after roadbed has been roughed in Authorized Officer and Road Builder will place culverts in best position.
- 9+50 - Install 24"x 40' CPP cross drain. Install culvert as described in Section 400. Station is an estimate after roadbed has been roughed in Authorized Officer and Road Builder will place culverts in best position.
- 12+50 - Install 24"x 40' CPP cross drain. Install culvert as described in Section 400. Station is an estimate after roadbed has been roughed in Authorized Officer and Road Builder will place culverts in best position.
- 17+89 - End new construction.

Road No. P5

Sta.

- 0+00 - Begin new construction. Begin clearing and grubbing as described in Section 200 within the posted ROW limits. Begin excavation and embankment as described in Section 300 as necessary to meet the roadbed typical shown in Section 150, install culverts as described in Sections 400, begin rock applications as described in Sections 150, 1000, and 1200, and Soil stabilization and erosion control measures will be required as described in Sections 1700 and 1800.
- 0+50 - Install 24"x 40' CPP cross drain. Install culvert as described in Section 400. Station is an estimate after roadbed has been roughed in Authorized Officer and Road Builder will place culverts in best position.
- 2+00 - Install 24"x 40' CPP cross drain. Install culvert as described in Section 400. Station is an estimate after roadbed has been roughed in Authorized Officer and Road Builder will place culverts in best position.

ROAD CONSTRUCTION WORKLIST

Road No. P5

Sta.

- 4+50 - Install 24"x 40' CPP cross drain. Install culvert as described in Section 400. Station is an estimate after roadbed has been roughed in Authorized Officer and Road Builder will place culverts in best position.
- 7+00 - Install 24"x 40' CPP cross drain. Install culvert as described in Section 400. Station is an estimate after roadbed has been roughed in Authorized Officer and Road Builder will place culverts in best position.
- 8+50 - Install 24"x 40' CPP cross drain. Install culvert as described in Section 400. Station is an estimate after roadbed has been roughed in Authorized Officer and Road Builder will place culverts in best position.
- 9+08 - End new construction.

Road No. P6

Sta.

- 0+00 - Begin new construction. Begin clearing and grubbing as described in Section 200 within the posted ROW limits. Begin excavation and embankment as described in Section 300 as necessary to meet the roadbed typical shown in Section 150, install culverts as described in Sections 400, begin rock applications as described in Sections 150, 1000, and 1200, and Soil stabilization and erosion control measures will be required as described in Sections 1700 and 1800.
- 0+00 - Install 24"x 40' CPP cross drain. Install culvert as described in Section 400. Station is an estimate after roadbed has been roughed in Authorized Officer and Road Builder will place culverts in best position.
- 3+00 - Install 24"x 40' CPP cross drain. Install culvert as described in Section 400. Station is an estimate after roadbed has been roughed in Authorized Officer and Road Builder will place culverts in best position.

ROAD CONSTRUCTION WORKLIST

Road No. P6

Sta.

- 5+00 - Install 24"x 40' CPP cross drain. Install culvert as described in Section 400. Station is an estimate after roadbed has been roughed in Authorized Officer and Road Builder will place culverts in best position.
- 7+15 - End new construction.

Road No. P7

Sta.

- 0+00 - Begin new construction. Begin clearing and grubbing as described in Section 200 within the posted ROW limits. Begin excavation and embankment as described in Section 300 as necessary to meet the roadbed typical shown in Section 150, install culverts as described in Sections 400, begin rocking applications as described in Sections 150, 1000, and 1200, and Soil stabilization and erosion control measures will be required as described in Sections 1700 and 1800.
- 1+00 - Install 24"x 40' CMP cross drain. Install culvert as described in Section 400. Station is an estimate after roadbed has been roughed in Authorized Officer and Road Builder will place culverts in best position.
- 4+00 - Install 24"x 40' CMP cross drain. Install culvert as described in Section 400. Station is an estimate after roadbed has been roughed in Authorized Officer and Road Builder will place culverts in best position.
- 7+00 - Install 24"x 40' CMP cross drain. Install culvert as described in Section 400. Station is an estimate after roadbed has been roughed in Authorized Officer and Road Builder will place culverts in best position.
- 9+00 - Install 24"x 40' CMP cross drain. Install culvert as described in Section 400. Station is an estimate after roadbed has been roughed in Authorized Officer and Road Builder will place culverts in best position.

ROAD CONSTRUCTION WORKLIST

Road No. P7

Sta.

- 11+00 - Install 24"x 40' CMP cross drain. Install culvert as described in Section 400. Station is an estimate after roadbed has been roughed in Authorized Officer and Road Builder will place culverts in best position.
- 13+00 - Install 24"x 40' CMP cross drain. Install culvert as described in Section 400. Station is an estimate after roadbed has been roughed in Authorized Officer and Road Builder will place culverts in best position.
- 14+06 - End new construction.

Road No. P8

Sta.

- 0+00 - Begin new construction. Begin clearing and grubbing as described in Section 200 within the posted ROW limits. Begin excavation and embankment as described in Section 300 as necessary to meet the roadbed typical shown in Section 150, install culverts as described in Sections 400, begin rock applications as described in Sections 150, 1000, and 1200, and Soil stabilization and erosion control measures will be required as described in Sections 1700 and 1800.
- 0+50 - Install 24"x 40' CPP cross drain. Install culvert as described in Section 400. Station is an estimate after roadbed has been roughed in Authorized Officer and Road Builder will place culverts in best position.
- 2+50 - Install 24"x 40' CPP cross drain. Install culvert as described in Section 400. Station is an estimate after roadbed has been roughed in Authorized Officer and Road Builder will place culverts in best position.
- 4+50 - Install 24"x 40' CPP cross drain. Install culvert as described in Section 400. Station is an estimate after roadbed has been roughed in Authorized Officer and Road Builder will place culverts in best position.
- 7+18 - End new construction.

ROAD CONSTRUCTION WORKLIST

Road No. P9

Sta.

- 0+00 - Begin new construction. Begin clearing and grubbing as described in Section 200 within the posted ROW limits. Begin excavation and embankment as described in Section 300 as necessary to meet the roadbed typical shown in Section 150, install culverts as described in Sections 400, begin rocking applications as described in Sections 150, 1000, and 1200, and Soil stabilization and erosion control measures will be required as described in Sections 1700 and 1800.
- 0+00 - Install 24"x 40' CPP cross drain. Install culvert as described in Section 400. Station is an estimate after roadbed has been roughed in Authorized Officer and Road Builder will place culverts in best position.
- 3+50 - Install 24"x 40' CPP cross drain. Install culvert as described in Section 400. Station is an estimate after roadbed has been roughed in Authorized Officer and Road Builder will place culverts in best position.
- 4+75 - Install 24"x 40' CPP cross drain. Install culvert as described in Section 400. Station is an estimate after roadbed has been roughed in Authorized Officer and Road Builder will place culverts in best position.
- 4+88 - End new construction.

Road No. P10

Sta.

- 0+00 - Begin new construction. Begin clearing and grubbing as described in Section 200 within the posted ROW limits. Begin excavation and embankment as described in Section 300 as necessary to meet the roadbed typical shown in Section 150, install culverts as described in Sections 400, begin rocking applications as described in Sections 150, 1000, and 1200, and Soil stabilization and erosion control measures will be required as described in Sections 1700 and 1800.
- 1+50 - Install 24"x 40' CPP cross drain. Install culvert as described in Section 400. Station is an estimate after roadbed has been roughed in Authorized Officer and Road Builder will place culverts in best position.

ROAD CONSTRUCTION WORKLIST

- 3+00 - Install 24"x 40' CPP cross drain. Install culvert as described in Section 400. Station is an estimate after roadbed has been roughed in Authorized Officer and Road Builder will place culverts in best position.
  
- 5+11 - End new construction.

U.S. DEPT. OF THE INTERIOR  
 Bureau of Land Management

NORTHWESTOREGON DISTRICT

**ROADSIDE BRUSHING  
 DETAIL SHEET**

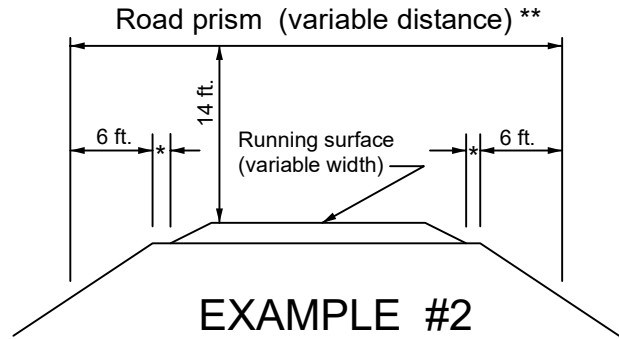
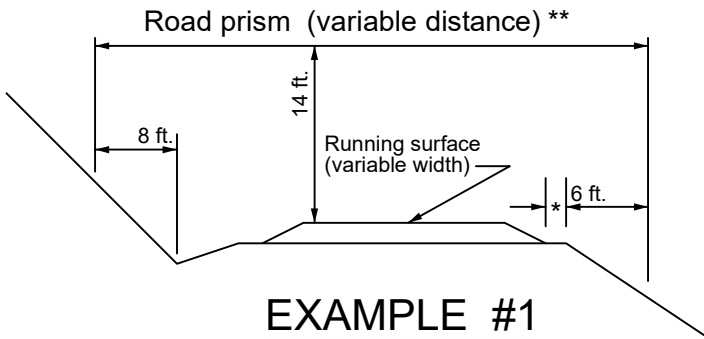

(NO SCALE)

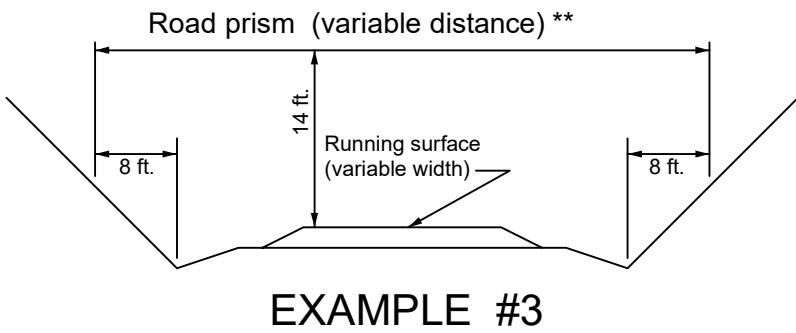

- \* Variable distance between running surface and start of fill slope.
- \*\* All areas within the variable distance shall be free of all vegetation capable of growing one (1) foot in height or higher and all overhanging limbs and branches 14 feet in elevation above the running surface.

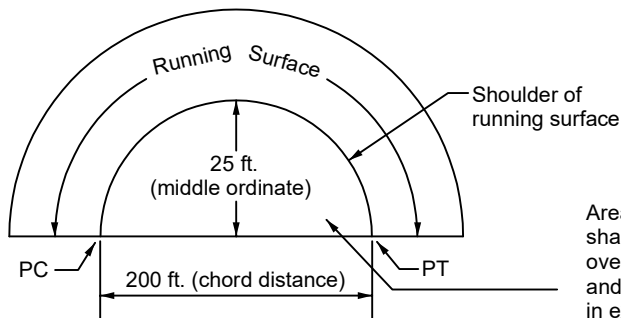

**SIGHT DISTANCE DIAGRAM**

Area to be cut: shall be free of overhanging limbs and all vegetation in excess of 1 foot in height.

**NOTE:**

Prior to beginning roadside brushing the purchaser shall establish a control section in a location determined by the Authorized Officer. This section will be used to physically and visually establish acceptable cutting and cleanup standards to be used for the remaining roadside brushing.



# U.S. DEPARTMENT OF THE INTERIOR

## Bureau of Land Management

### Northwest Oregon District

EXHIBIT C  
 Sale Name: Golden Necar  
 Contract No: ORNO2-TS-2026.0203

Sheet 52 of 61

NOTE:  
 DESIGN VARIATIONS IN FASTENERS,  
 (STRAPS, BARS & WELDS) WHICH  
 PROVIDE A TENSILE STRENGTH OF  
 7500 LBS. ARE PERMISSIBLE.

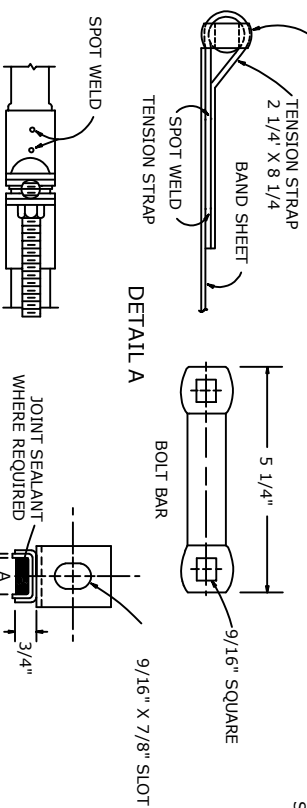

DIMENSIONS IN INCHES

T	A	PIPE WALL THICKNESS
.079	3/4	.109 OR LIGHTER
.109	1	.138 OR HEAVIER

SECTION A-A

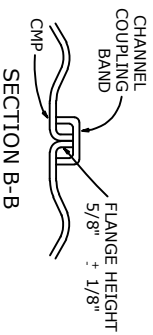

**CHANNEL  
 BAND  
 COUPLER**

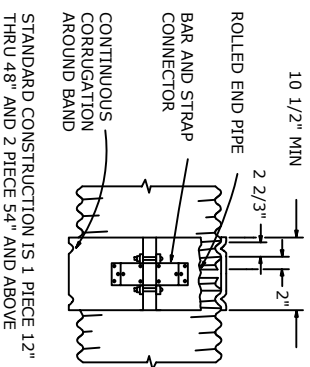

THE HUGGER COUPLER BAND OR AN APPROVED EQUIVALENT COUPLER BAND SHALL BE MADE OF THE SAME MATERIAL AND FINISH AS THE PIPES JOINED. THE COUPLER BANDS SHALL HAVE A MINIMUM WIDTH OF 10 1/2 INCHES AND MAY BE TWO NUMERICAL THICKNESSES LIGHTER THAN THE GAGE OR THICKNESS DESIGNATED FOR THE CONDUIT JOINED. THE BAND SHALL BE DESIGNED TO BE DRAWN TOGETHER WITH TWO 1/2 INCH BOLTS THROUGH USE OF A BAR AND STRAP SUITABLY WELDED TO THE BAND. THE BAND SHALL ENGAGE AND MESH WITH THE SECOND ANNULAR CORRUGATION INWARD FROM THE END OF EACH OF THE CONDUIT SECTIONS JOINED.

WHEN DESIGNATED ON THE PLANS OR ON THE SPECIAL PROVISIONS, GASKETS SHALL BE INSTALLED WHEN THE "HUGGER" TYPE, OR AN APPROVED EQUIVALENT COUPLER BAND IS INSTALLED ON SPILLWAY, OVERSIDE OR DOWN DRAINS.

### "HUGGER" COUPLER BANDS

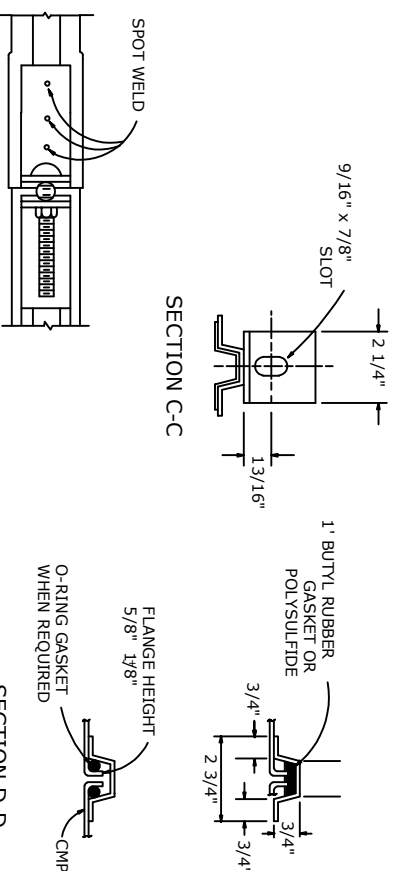

**FLANGED END COUPLER**

CULVERT SIZE INCHES	CORRUGATED						FLAT-DIMPLED	
	STD. ANNULAR WIDTH	NO. OF BOLTS	HELICAL WIDTH	NO. OF BOLTS	3" X 1" WIDTH	NO. OF BOLTS	6" X 1" WIDTH	NO. OF BOLTS
UNDER 18	7	2	7	2	3	3	10 1/2	2
18 TO 54	12	3	12	3	14	3	10 1/2	2
OVER 54	24	5	24	5	24	5	16 1/2	4

DATA IN THIS BLOCK DOES NOT APPLY TO PERFORATED PIPE UNDERDRAIN. FOR BANDS WITH "PUNCH-OUT" TYPE CONNECTIONS, 2 BOLTS ARE PERMISSIBLE FOR EACH LAP. BANDS SHALL LAP 1/2 WIDTH ONTO EACH SECTION OF PIPE AND MUST FULLY ENCRIRCLE THE JOINT FORMING A NEARLY WATERTIGHT CONNECTION.

- Ⓐ BANDS WITH ANGLES
- Ⓑ BANDS WITH TENSION TYPE CONNECTIONS

ALWAYS THINK SAFETY

UNITED STATES DEPARTMENT OF THE INTERIOR Bureau of Land Management SALEM DISTRICT - OREGON	
<b>CULVERT BAND DETAILS</b>	
DRAWN: J. BEARD ENGINE D.O.	SCALE: not to scale
DATE: 1980	SHEET: 1 OF 1

# U.S. DEPARTMENT OF THE INTERIOR

## Bureau of Land Management

### Northwest Oregon District

EXHIBIT C  
 Sale Name: Golden Nectar  
 Contract No: ORNO2-TS-2026.0203  
 Sheet 58 of 61

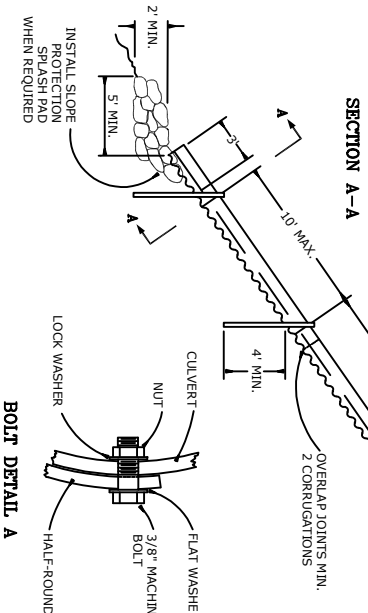
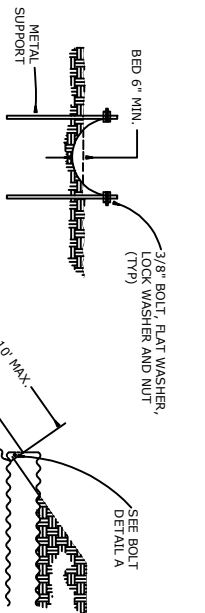

#### HALF ROUND DOWNSPOUT

- NOTE:
1. THE HALF ROUND SHALL BE ONE DIAMETER SIZE LARGER AND OF THE SAME MATERIAL AND COATING AS THE CULVERT IT IS ATTACHED TO.
  2. THE HALF ROUND SHALL BE FABRICATED FROM 16 GAUGE METAL WITH 2 2/3" X 1/2" CORRUGATIONS.
  3. SUPPORTS MAY BE STEEL BAR, ANGLE IRON OR APPROVED EQUIVALENT METAL POSTS.

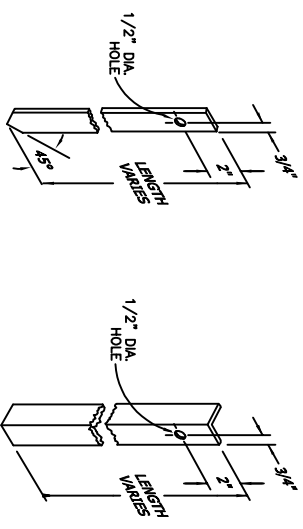

1 1/2" X 1/4" STEEL BAR SUPPORT  
 1 1/2" X 1 1/2" X 1/4" ANGLE IRON SUPPORT  
 METAL SUPPORT DETAIL

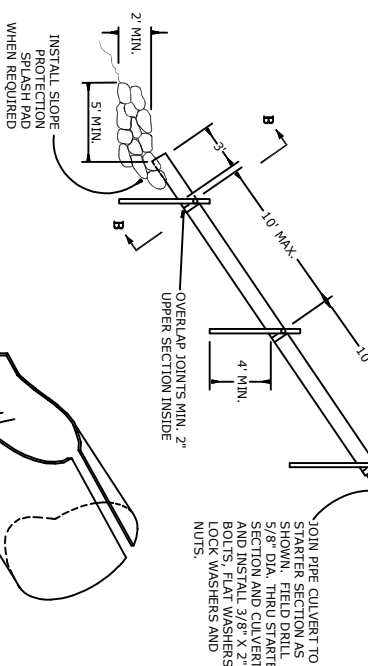
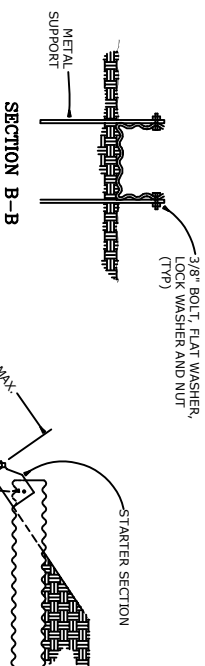

#### RECTANGULAR FLUME

- NOTE:
1. THE FLUME SHALL BE FABRICATED FROM 16 GAUGE CULVERT STOCK WITH 2 2/3" X 1/2" CORRUGATIONS.
  2. THE STARTER SECTION SHALL BE FABRICATED FROM 16 GAUGE NON-CORRUGATE CULVERT STOCK
  3. ADJUSTABLE WIDTH FLUMES ARE AVAILABLE FOR APPLICATIONS OVER 24" WIDE. INSTALL ACCORDING TO MANUFACTURER.
  4. SUPPORTS MAY BE STEEL BAR, ANGLE IRON OR APPROVED EQUIVALENT POSTS.

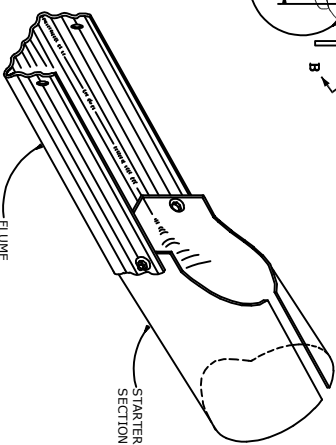

#### GENERAL NOTES

1. THE LENGTH OF THE DOWNSPOUT SHALL BE DETERMINED AT THE TIME OF INSTALLATION.
2. FABRICATION AND INSTALLATION OF ALL GALVANIZED STEEL DOWNSPOUTS SHALL CONFORM TO AASHTO M56, M218; ALUMINUM ALLOY TO AASHTO M196; ALUMINIZED TYPE II TO AASHTO 36, M196.
3. ALL STEEL NUTS, BOLTS AND WASHERS SHALL BE GALVANIZED. (ASTM A307, A153)
4. SLOPE PROTECTION SPLASH PADS, WHEN REQUIRED, SHALL BE A MIN. 2 FT. WIDE X 5 FT. LONG X 2 FT. DEEP. INDIVIDUAL ROCKS SHALL BE 10" - 14" IN SIZE.

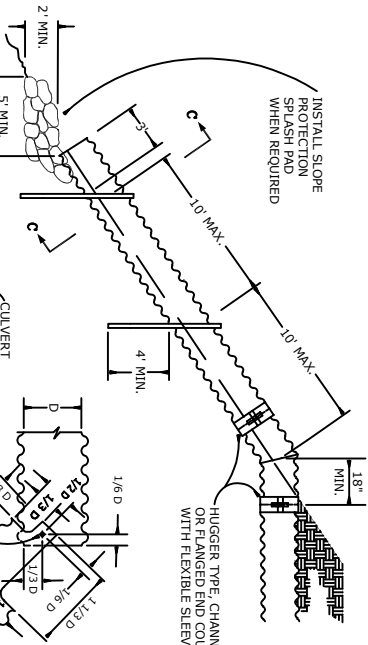
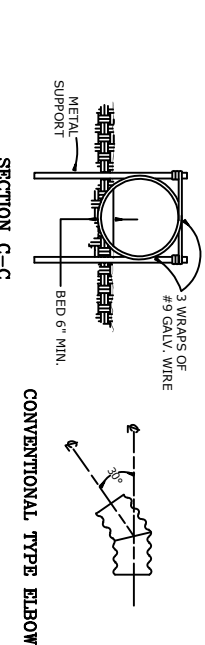

#### FULL ROUND DOWNSPOUT

- NOTE:
1. THE ELBOW AND SPILLWAY SECTION SHALL BE OF THE SAME DIAMETER, MATERIAL AND COATING AS THE CULVERT IT IS ATTACHED TO.
  2. THE SPILLWAY SECTION SHALL BE FABRICATED FROM 16 GAUGE METAL WITH 1 2/3" X 1/2" CORRUGATIONS.
  3. SUPPORTS MAY BE COMMERCIAL STEEL FENCE POSTS, STEEL BAR, ANGLE IRON OR APPROVED EQUIVALENT METAL POSTS.
  4. CONNECTION BETWEEN HELICALLY CORRUGATED AND ANNULAR PIPE SHALL REQUIRE A SPECIAL ADAPTER COUPLING BAND.

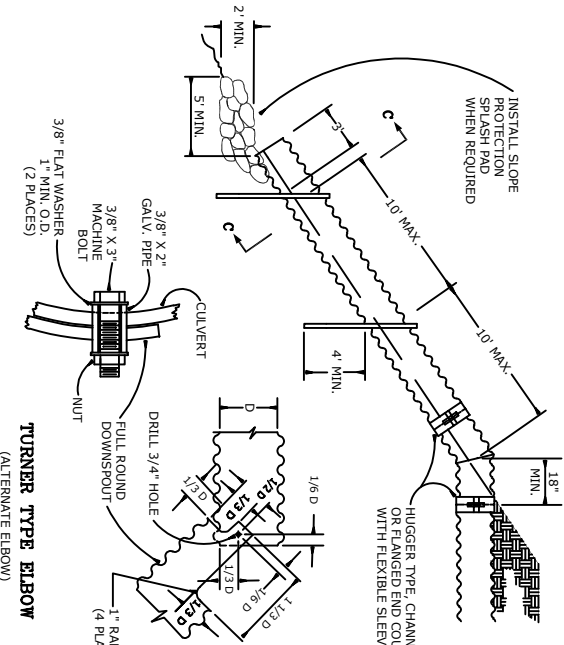

ALWAYS THINK SAFETY

UNITED STATES DEPARTMENT OF THE INTERIOR Bureau of Land Management SALEM DISTRICT - OREGON	
<b>DOWNSPOUT INSTALLATION DETAILS</b>	
DRAWN: J. RENO, Egores 00.	SCALE: not to scale
DATE: 1990	SHEET: 1 OF 1

# U.S. DEPARTMENT OF THE INTERIOR Bureau of Land Management Northwest Oregon District

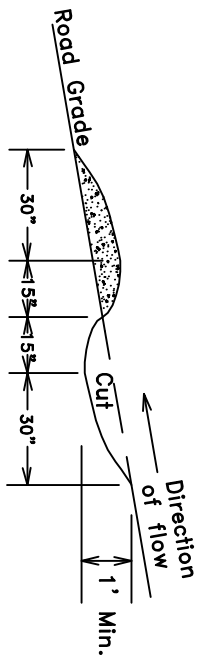

1. Waterbars shall be constructed as shown.
2. Exact locations will be flagged by the Authorized Officer prior to construction.
3. All waterbars shall be skewed 30 degrees.
4. Waterbars shall extend from the cut bank to the fill slope and be readily crossed by passenger type vehicles.
5. See Itemized Project List for quantities and locations.

Typical Waterbar Details  
(Not to scale)

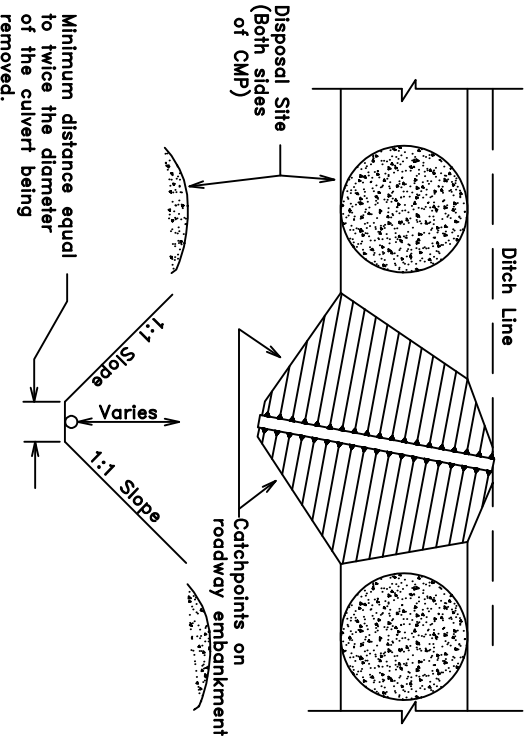

1. Culverts shall be removed as shown
2. Removed culverts shall be disposed of as directed by the Authorized Officer
3. The exposed areas shall be seeded in accordance with Section 1800, Exhibit C
4. Excavated material shall be stockpiled as shown

Typical Culvert Removal Details  
(Not to Scale)

1. Roads shall be blocked as shown using available debris
2. All barricade material shall be stock piled in a large configuration of stumps, logs, large rocks, woody material and earth. Earth will be used to aid debris from being cut, stolen or moved from site.
3. Barricade locations will be flagged by the Authorized Officer prior to construction
4. The barricade shall span the entire width of the roadway and shall sufficiently block all vehicular access to the road

Typical Debris Barricade Details  
(Debris & Earth Berm)  
(Not to Scale)

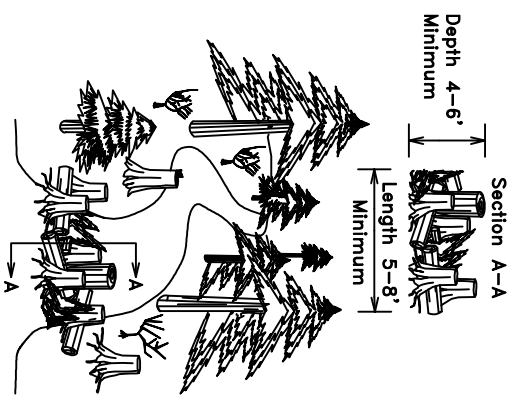



UNITED STATES DEPARTMENT OF THE INTERIOR  
Bureau of Land Management  
**Road Plan Map: Renovation and Improvement**  
T. 14 S., R. 7 W., Section 3 W.M.

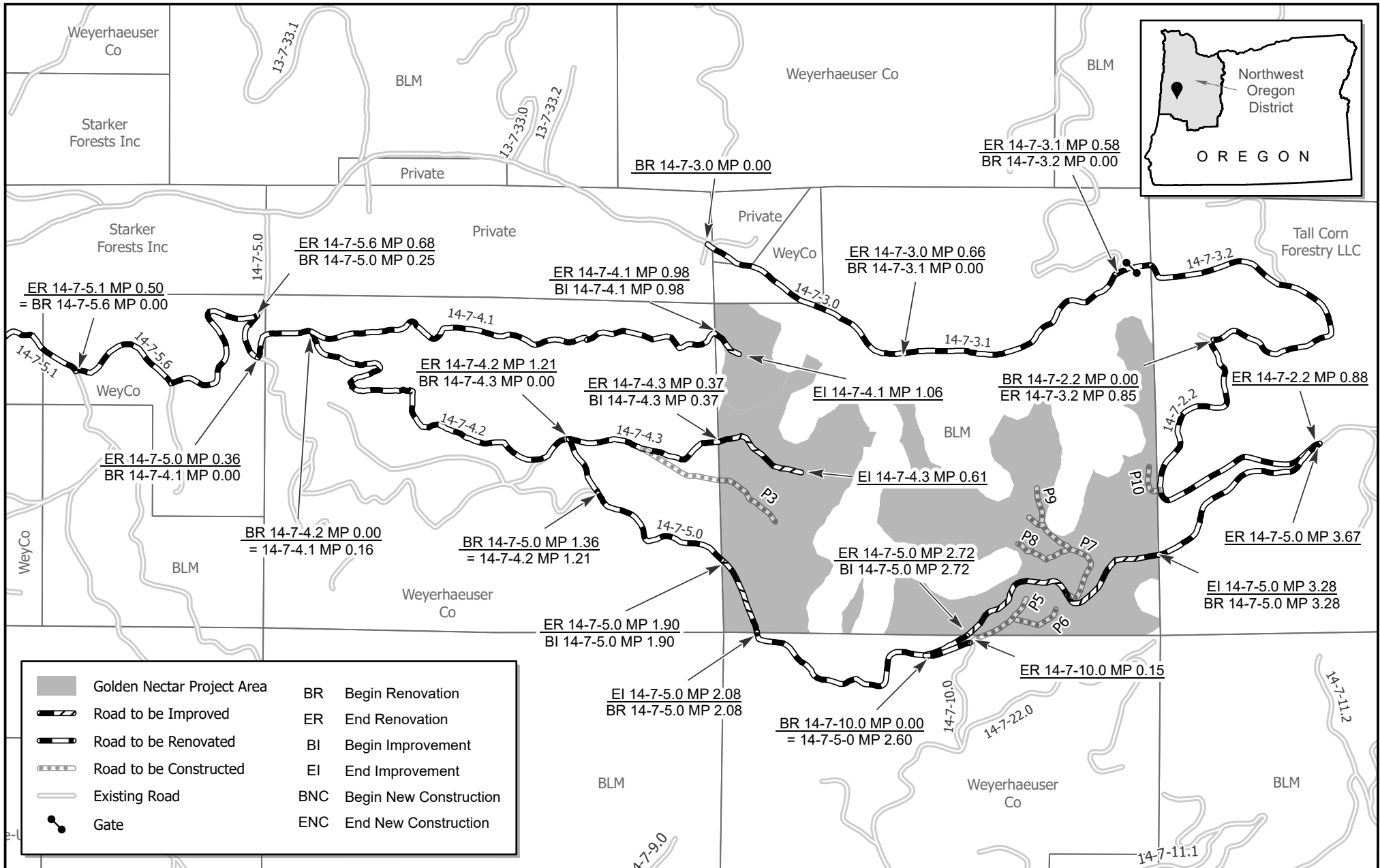

No warranty is made by the Bureau of Land Management as to the accuracy, reliability or completeness of these data for individual use or aggregate use with other data. Original Data was compiled from multiple source data and may not meet U.S. National Mapping Accuracy Standard of the Office of Management and Budget. 6/15/2026



UNITED STATES DEPARTMENT OF THE INTERIOR  
 Bureau of Land Management  
**Road Plan Map: New Construction**  
 T. 14 S., R. 7 W., Section 3 W.M.

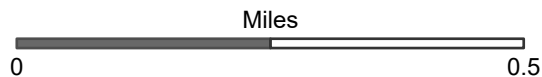
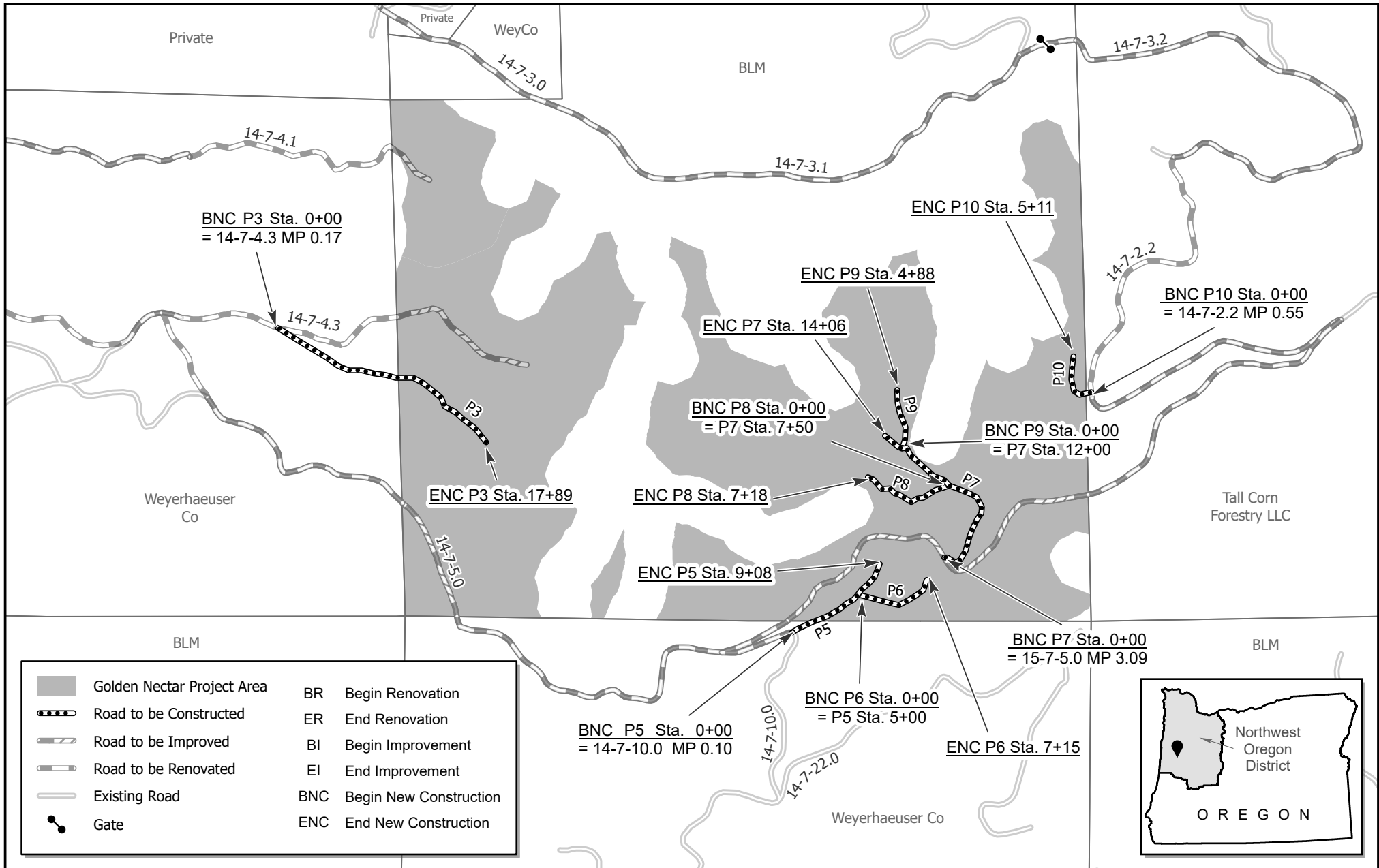

No warranty is made by the Bureau of Land Management as to the accuracy, reliability or completeness of these data for individual use or aggregate use with other data. Original Data was compiled from multiple source data and may not meet U.S. National Mapping Accuracy Standard of the Office of Management and Budget. 6/15/2026

United States  
Department of the Interior  
Bureau of Land Management  
Northwest Oregon District

Timber Sale Contract  
Purchaser Road Maintenance Specifications

SECTION	SHEET	DESCRIPTION
	1	Table of Contents
3000	2	General
3100	2-4	Operational Maintenance
3200	4-5	Seasonal Maintenance
3300	5	Final Maintenance
3400	6	Other Maintenance
3500	6	Decommissioning

## ROAD MAINTENANCE SPECIFICATIONS

### GENERAL - 3000

- 3001 The Purchaser shall be required to maintain all roads listed and/or referenced in Section 44, Special Provisions, and as shown on the Exhibit E map of this contract in accordance with Sections 3000, 3100, 3200, 3300 and 3400 of this Exhibit.
- 3002 The Purchaser shall maintain the cross section of existing dirt or graveled roads to the existing geometric standards. Any roads required to be constructed, improved, or renovated under the terms of this contract shall be maintained to the geometric standards required in Exhibit C of this contract.
- 3003 The minimum required maintenance on any roads shall include the provisions specified in Subsections 3101, 3104, and 3105.
- 3004 The Purchaser shall be responsible for providing timely maintenance and cleanup on any roads with logging units substantially completed, prior to moving operations to other roads, unless otherwise permitted by the Authorized Officer. The maximum length of non-maintained or non-cleanup of the road prism shall not exceed the sum of one (1) mile at any time. Release of maintenance requirements may be granted, upon written request, when the conditions specified in Sections 3300 and 3400 are met satisfactorily.

### OPERATIONAL MAINTENANCE - 3100

- 3101 The Purchaser shall blade and shape the road surface and shoulders with a motor grader. Banks shall not be undercut. Back blading with tractors or similar equipment will be allowed only around landings and other areas when approved by the Authorized Officer.
- 3102 The Purchaser shall furnish and place a minimum of 500 cubic yards of 1 ½" aggregate conforming to the requirements in Section 1000 of Exhibit C of this contract on the roadway and landings at locations and in the amounts designated by the Authorized Officer. The aggregate gradation and compacted depth will also be designated by the Authorized Officer. This aggregate shall be used to repair surface failures, landings and areas of depleted surface depth excluding damages covered by Section 12 of this contract. The aggregate shall be furnished, hauled, placed, spread, and compacted, by use of dump trucks, water trucks, and motor grader or similar equipment. If the maintenance rock is not needed, then it shall be stockpiled in a place determined by the Authorized Officer.

OPERATIONAL MAINTENANCE - 3100

- 3103 The purchaser shall maintain established berms and place additional berms using adjacent material where needed to protect fills as directed by the Authorized Officer.
- 3104 The purchaser shall perform other road cleanup including removal of debris, fallen timber, bank slough, and slides which can practicably be accomplished by a motor grader, rubber tired front end bucket loader, rubber tired backhoe or comparable equipment, and by the use of hand tools.
- 3104a Removal of bank slough and slide material includes placement of material at the nearest designated, suitable disposal site where material cannot erode into streams, lakes, or reservoirs or cause undue damage to road fill slopes which have been planted or mulched to control soil erosion as directed by the Authorized Officer.
- 3104b The Purchaser shall be responsible for removal of all slides or slough, up to fifteen station yards in quantity, at any one site. This work includes unlimited multiple sites on all roads required to be maintained by the Purchaser.
- Prior to removal of any slough or slide material exceeding fifteen station yards at any one site, the Purchaser and the Authorized Officer or their Authorized Representatives shall agree in writing, in the field, to the quantity of material, method of disposal, and the disposal site. Work may commence immediately after agreement.
- Upon completion of agreed upon work, a reduction in timber sale purchase price will be made to offset the cost of the work, based on current BLM Road Cost Guide. Adjustments in purchase price for completed work shall be made as necessary and no less than one per year when actual work is ongoing.
- 3105 The Purchaser shall be responsible for maintaining normal flow in drainage structures. This includes cleaning out drainage ditches, catch basins, clearing pipe inverts of sediment and other debris lodged in the barrel of the pipe, and maintaining water dips and water bars using equipment specified in Subsection 3104 and other culvert cleaning and flushing equipment.

OPERATIONAL MAINTENANCE - 3100

3106 The Purchaser shall be responsible for repair and replacement of all materials eroded from road shoulders and fill slopes, up to fifteen station yards in quantity, at any one site. This work includes unlimited multiple sites on all roads required to be maintained by the Purchaser. Prior to repair and replacement of eroded material exceeding fifteen station yards at any one site, the Purchaser and the Authorized Officer or their Authorized Representatives shall agree in writing, in the field, to the quantity of material, borrow source and method of repair. Work may commence immediately after agreement.

Upon completion of agreed upon work, a reduction in timber sale purchase price will be made to offset the cost of the work based upon current BLM Road Cost Guide. Adjustments in purchase price for completed work shall be made as necessary, and no less than once per year when actual work is ongoing.

3107 The Purchaser shall cut or trim trees and brush which obstructs vision or prevents the safe passage of traffic along the traveled way when directed by the Authorized Officer.

The Purchaser shall also cut trees or brush encroaching on the road prism that are a result of his activities or winter damage during the contract period. Disposal of such vegetative material shall be by scattering below the road.

3108 The Purchaser shall avoid fouling gravel or bituminous surfaces through covering with earth and debris from side ditches, slides or other sources. The Purchaser shall also avoid blading surfacing material off the running surface of the roadway. Skidding of logs on the roadway in or outside designated logging units is not authorized without prior written approval by the Authorized Officer. Repair required caused by such skidding activity is not considered maintenance and shall be repaired at the Purchaser's expense.

SEASONAL MAINTENANCE - 3200

3201 The Purchaser shall perform preventative maintenance at the end of Purchaser's hauling each season and during non-hauling periods which occur between other operations on the contract area. This includes requirements specified in Section 3100.

3202 The purchaser shall perform and complete maintenance specified in Sections 3000, 3100, and 3200 on all roads maintained by him, prior to October 31 each year, except as specified in Subsection 3203, after initial commencement of construction or logging operations. Thereafter, all roads shall have continuous preventive maintenance and road cleanup until suspension of seasonal operations. This includes all roads used and not used during the proceeding operating seasons.

SEASONAL MAINTENANCE - 3200

- 3203 The Purchaser shall complete road cleanup and maintenance, as specified in Section 3100, at the completion of logging operations on any roads located in an area separate from the area where logging activities will resume.
- 3204 The Purchaser shall be responsible for performing post storm inspections and maintenance during the winter season to minimize erosion and potential road or watershed damage.

FINAL MAINTENANCE - 3300

- 3301 The Purchaser shall complete final maintenance and/or damage repairs on all roads used under the terms of their contract within thirty (30) calendar days following the completion of hauling and in accordance with Sec. 16 (b) of this contract. This work shall include any maintenance and/or damage repairs specified in Sections 3000, 3100, and 3200 necessary to meet the conditions specified in Subsection 3002 and shall be executed in accordance with Subsection 3302 of this section.

The Authorized Officer may grant acceptance of Purchaser's maintenance responsibility in part where certain individual roads or road segments are no longer of any use to the Purchaser's remaining removal operations, providing that all contract requirements as specified under Sec. 16(b), Special Provisions, Sections 3000, 3100, 3200 and 3300 of the maintenance specifications have been completed and a relinquishment of cutting and removal rights on cutting units tributary to these roads is signed by the Purchaser. Request for partial acceptance must be submitted in writing by the Purchaser.

- 3302 The Purchaser shall perform final road maintenance only when weather or soil moisture conditions are suitable for normal maintenance equipment operations as determined by the Authorized Officer.

If final maintenance is delayed after the date required in Subsection 3301 of this contract by adverse soil moisture or unsuitable equipment operating conditions, the Purchaser will be notified by the Authorized Officer when soil moisture and equipment operating conditions are suitable. The Purchaser shall then be required to complete final maintenance within 30 days.

OTHER MAINTENANCE - 3400

3401 The Purchaser shall repair any damage to road surfaces that was specified under Subsection 3108. This repair includes restoring the roadway to the designed standard and replacement of surfacing with approved surface material. This repair is not limited to use of equipment specified in Subsection 3104.

3402 The Purchaser shall be permitted to remove ice and snow from roads authorized for use under this contract only when prior written approval has been secured from the Authorized Officer. The Purchaser shall submit a written request for permission to remove ice and snow in advance of the date operations are to begin.

Upon receiving written authorization for ice or snow removal, the Purchaser will perform the work according to the conditions and equipment requirements set forth in the authorization.

DECOMMISSIONING – 3500

3501 Decommissioning shall consist of installing water bars, seeding and mulching of exposed soils, blocking road entrances, and de-compacting road surface as directed by the Authorized Officer and in accordance with Section 2700 of Exhibit C of this contract. Seeding and mulching of exposed soils will be required and must be in accordance with Section 1800 of Exhibit C of this contract.

DECOMMISSIONING – 3500

3503 Decommissioning shall be performed on existing roads in accordance with these specifications, and as shown on the plans at the following locations:

ROAD NO OR SITE	FROM MP/STA.	TO MP/STA.	DECOMMISSION
P3	0+00	17+89	Install six water bars, cover with seed and mulch/straw.
P5	0+00	9+08	Install four water bars, cover with seed and mulch/straw.
P6	0+00	7+15	Install four water bars, cover with seed and mulch/straw.
P7	0+00	14+06	Install five water bars, cover with seed and mulch/straw.
P8	0+00	7+18	Install five water bars, cover with seed and mulch/straw.
P9	0+00	4+88	Install five water bars, cover with seed and mulch/straw.
P10	0+00	5+11	Install five water bars, cover with seed and mulch/straw.



UNITED STATES DEPARTMENT OF THE INTERIOR  
 Bureau of Land Management  
**Road Use and Maintenance Map**  
 T. 14 S., R. 7 W., Section 3 W.M.

Golden Nectar  
 ORN02-TS-2026.0203  
**EXHIBIT E**

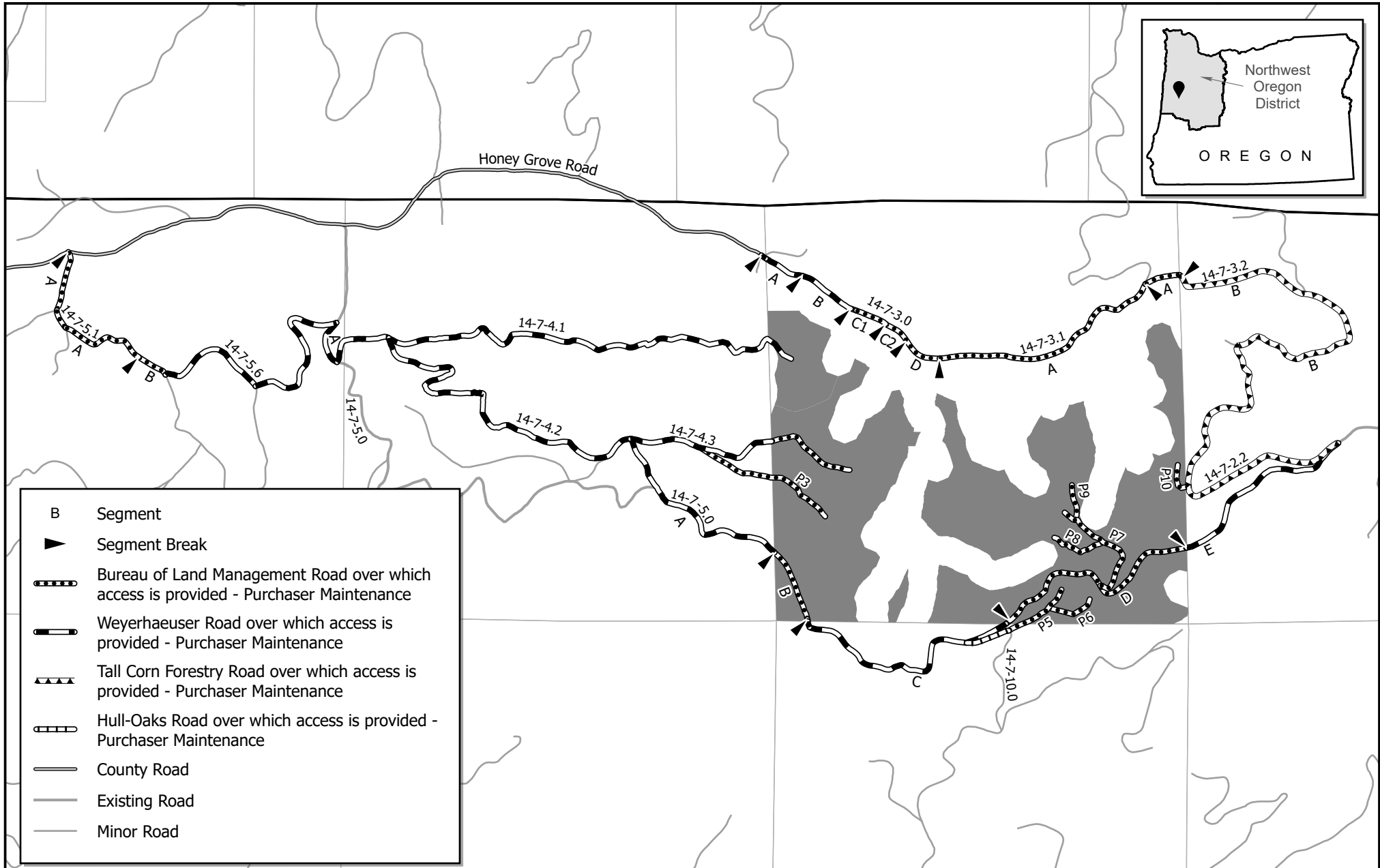

- B Segment
- ▶ Segment Break
- ▬ Bureau of Land Management Road over which access is provided - Purchaser Maintenance
- ▬ Weyerhaeuser Road over which access is provided - Purchaser Maintenance
- ▬ Tall Corn Forestry Road over which access is provided - Purchaser Maintenance
- ▬ Hull-Oaks Road over which access is provided - Purchaser Maintenance
- ▬ County Road
- ▬ Existing Road
- ▬ Minor Road



No warranty is made by the Bureau of Land Management as to the accuracy, reliability or completeness of these data for individual use or aggregate use with other data. Original Data was compiled from multiple source data and may not meet U.S. National Mapping Accuracy Standard of the Office of Management and Budget. 6/15/2026



**TIMBER SALE CONTRACT MAP - ORN02-TS-2026.0203**

T. 14 S., R. 7 W., Section 3 W.M.

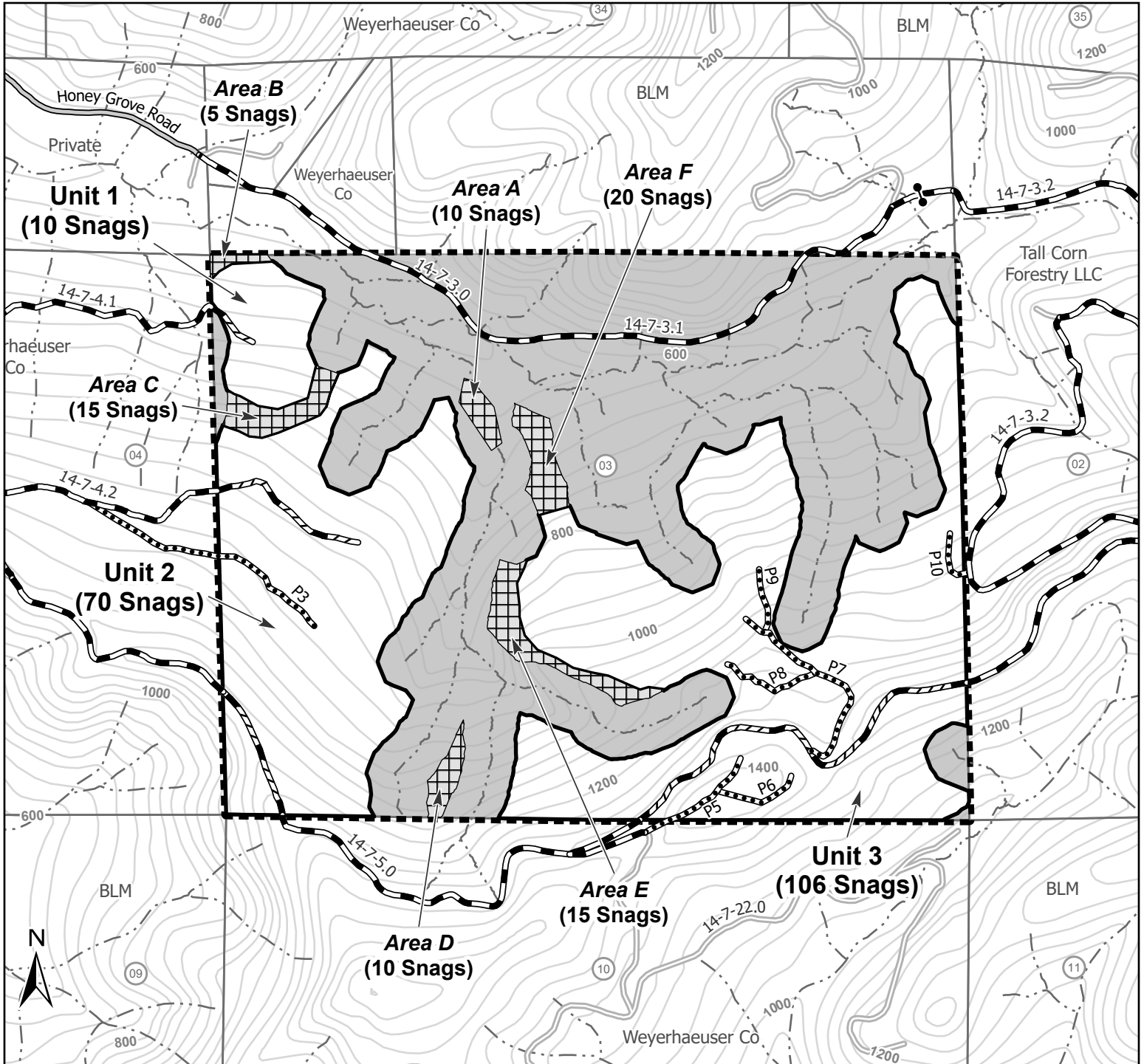

Contour Interval: 40 ft (LiDAR)

- Boundary Contract Area
- Boundary Cutting Area
- Reserve Area
- Snag Creation Area (Marked Trees)
- Stream
- Road to be Constructed
- Road to be Improved
- Road to be Renovated
- County Road
- Existing Road
- Gate

Harvest Area	235 Acres
Right of Way Area	3 Acres
Reserve Area	242 Acres
<b>Total Contract Area</b>	<b>480 Acres</b>

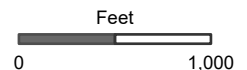

NOTES: Boundary of Harvest areas are painted orange and posted. Unit acres do not include existing roads or Rights-of-Way.

## **EXHIBIT F**

### **Snag Creation Requirements**

#### Snag Creation Guidelines

Within the Unit Areas, as shown on Exhibit F, the Purchaser shall designate and create one-hundred eighty-six (186) trees for snag creation, selected from trees painted with orange paint above and below stump height (i.e. Reserve Trees),  $\geq 20$  inches DBH. In the Snag Creation Areas, as shown on Exhibit F, the purchaser shall designate and create seventy-five (75) snags. Trees designated by the Purchaser for snag creation in the Snag Creation Areas shall be selected using the following general specifications.

- A. Base-Girdled, High-Girdled, or Topped trees shall be well distributed, no more than ten (10) snags per acre, within Unit boundaries or Snag Creation Areas, as shown on Exhibit F map, or as directed by the Authorized Officer. Do not create snags within falling distance of power lines, structures or roads that will remain open after harvesting activities are complete.
- B. Excessive damage to reserve timber, as determined by the Silviculturist and/or Authorized Officer, where orange painted reserve trees  $\geq 20$  inches DBH are subject to excessive damage, may be counted towards snag requirements.
- C. Trees designated to be created as snags shall be  $\geq 20$  inches DBH, when feasible, unless there are not enough trees  $\geq 20$  inches DBH, then smaller diameter trees can be selected. Trees designated for snag creation shall not exceed 40 inches DBH. Trees designated for snag creation shall be Douglas-fir, western redcedar, or other conifer species. Hardwoods should not be designated for snag creation unless there are not enough conifer trees present to meet the snag creation requirement.
- D. Approximately one-third of the trees to be treated shall be High-Girdled. Approximately one-third of the trees to be treated shall be Base-Girdled. Approximately one-third of the trees to be treated shall be Topped. These treatment types are described as follows
  1. High-girdled – girdling height of live trees will vary by stand age and should range from 50-120 feet, or the top third of the tree. Trees high-girdled shall retain 15-25 live limbs that are at least 5 feet in length below the girdled site. All cuts will completely sever the cambium but not exceed  $\frac{1}{2}$  inch depth into the wood of the tree. High-girdled trees shall be marked with high visibility pink glo-type flagging around the bole at DBH and two pieces of flagging tied to a branch, or bole, directly below the girdling site.
  2. Base-girdled – girdle site height shall be at or below DBH. All cuts will completely sever the cambium but not exceed  $\frac{1}{2}$  inch depth into the wood of the tree. All cuts will be free of sawdust and debris. Girdled trees shall be marked with high visibility pink glo-type flagging around the bole at DBH.

3. Topped - topping height of live trees will vary by stand age and should range from 50-120 feet, or the top-third of the tree. Trees topped shall retain 15-25 live limbs that are at least 5 feet in length below the topped site. Topped trees shall be marked with high visibility pink glo-type flagging around the bole at DBH.
- E. Because post-harvest windthrow may impact portions of harvest Units, the Authorized Officer will provide direction if excessive blowdown occurs and there are not enough trees remaining to designate enough snags to meet the snag creation requirement. Trees designated as snags to be created are located in harvest Units and Snag Creation Areas, as shown in table below, and on the attached map.

Timber Sale Unit	Snags to Create
Unit 1	10
Unit 2	70
Unit 3	106
Area A	10
Area B	5
Area C	15
Area D	10
Area E	15
Area F	20
<b>Total</b>	<b>261</b>

## Illustration #1 – High-Girdling

Crown Girdling Specifications:

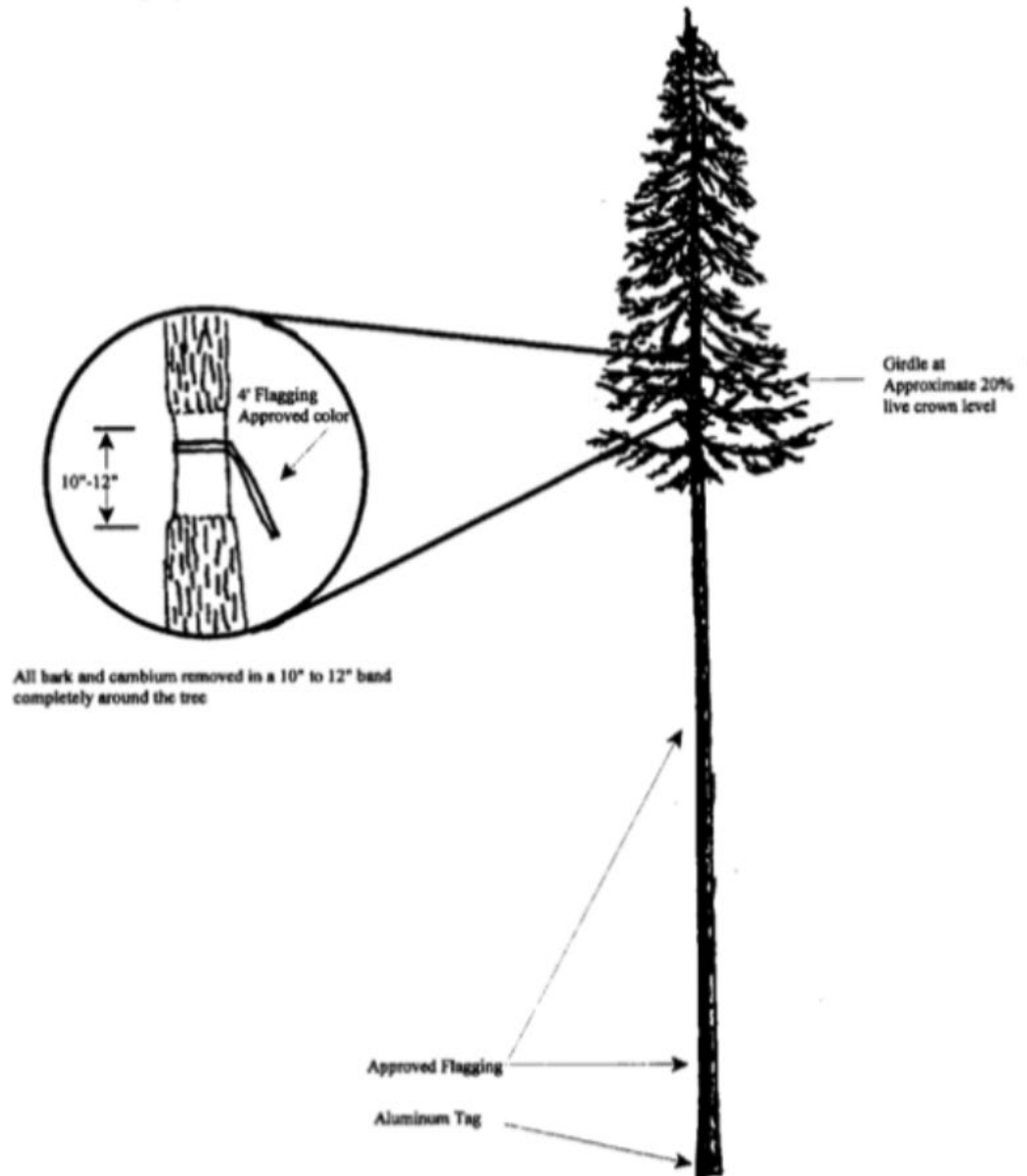

**Illustration #2 – Saw-topping.**



**Illustration #3 – Basal Girdling**

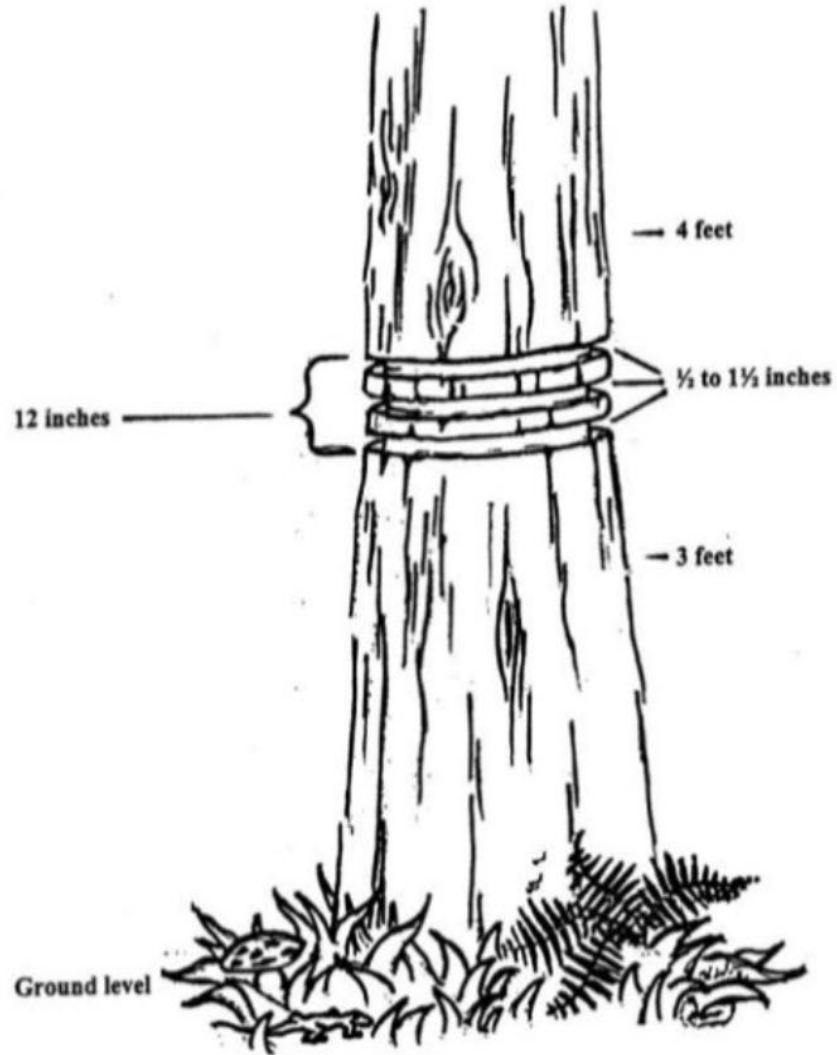

### **Snag Documentation Guidelines**

Basic information about each snag created shall be documented in a spreadsheet or other acceptable format (e.g. Excel, GPX, Shapefile) to be submitted to the authorized officer as each treatment unit is completed. The required information for each snag created shall include: RecordID, UnitID, TreeSpecies, DBH, TreeMark, Treatment, and Notes. These attributes are described as follows:

RecordID = Data line number starting at 1 and ascending.

UnitID = Timber Sale unit number as identified on Exhibit A.

TreeSpecies = tree species, example: DF = Douglas-fir, WH = western hemlock.

DBH = diameter at breast height to nearest inch.

TreeMark = marking on tree: S-mark, W-mark, Ring Mark, No Mark, Other (see Notes).

Treatment = snag treatment: SawTop, HighGirdle, BaseGirdle, ExistingSnag, RootSprung, Other (see Notes).

Notes = optional input; can be used to explain other values used for Tree Mark or Treatment.

INSERT 7 of 7 Map



**United States  
Department of the Interior  
Bureau of Land Management**

**Timber Appraisal**

---

<b>Sale Name:</b> Golden Nectar	<b>Sale Date:</b> Wednesday, July 22, 2026
<b>BLM District:</b> NW Oregon DO	<b>Unit of Measure:</b> 16' MBF
<b>Contract #:</b> ORN02-TS-2026.0203	<b>Contract Term:</b> 36 months
<b>Sale Type:</b> Advertised	<b>Contract Mechanism:</b> 5450-003 Lump Sum Sale of Timber and other Wood Products

---

**Content**

**Timber Appraisal Summary**  
**Stumpage Summary**  
**Unit Summary**  
**Stump to Truck**  
**Transportation**  
**Engineering Allowances**  
**Other Allowances**

**Prepared By:** Barclay, Brian W - 6/15/2026

**Approved By:** Rainey, Matthew D - 6/15/2026

## Legal Description of Contract Area

Land Status	County	Township	Range	Section	Subdivision	Meridian
O&C	Benton	14S	7W	3	S1/2NE1/4, S1/2NW1/4, S1/2	Willamette

## Species Totals

Species	Net	Gross Merch	Gross	# of Merch Logs	# of Cull Logs	# of Trees
Douglas Fir	10,546.0	11,086.0	11,142.0	110,083	1,125	18,300
Western Hemlock	1,392.0	1,488.0	1,488.0	17,071	0	2,780
Red Alder	553.0	607.0	633.0	11,134	0	2,653
Western Redcedar	354.0	408.0	408.0	3,340	0	824
Bigleaf Maple	304.0	324.0	324.0	5,182	0	2,293
Grandfir	145.0	154.0	154.0	1,763	220	294
<b>Totals</b>	<b>13,294.0</b>	<b>14,067.0</b>	<b>14,149.0</b>	<b>148,573</b>	<b>1,345</b>	<b>27,144</b>

## Cutting Area Acres

Regeneration Harvest Acres	Partial Cut Acres	Right of Way Acres	Total Acres	Net Volume per Acre
235.0	0.0	3.0	238.0	55.9

**Logging Costs**

Stump to Truck	\$1,906,616.34
Transportation	\$1,055,025.00
Road Construction	\$1,075,891.87
Maintenance/Rockwear	\$71,434.18
Road Use	\$133,212.59
Other Allowances	\$81,032.00
<b>Total:</b>	<b>\$4,323,211.98</b>
<b>Total Logging Cost per MBF:</b>	<b>\$325.20</b>

**Utilization Centers**

<u>Location</u>	<u>Distance</u>	<u>% of Net Volume</u>
Eugene OR	50.0 miles	100%

**Profit & Risk**

Profit	11%
Risk	0%
<b>Total Profit &amp; Risk</b>	<b>11%</b>

**Tract Features**

<b>Quadratic Mean DBH</b>	18.5 in
<b>Average GM Log</b>	95 bf
<b>Average Volume per Acre</b>	55.9 mbf
<b>Recovery</b>	94%
<b><u>Net MBF volume:</u></b>	
<b>Green</b>	13,294.0 mbf
<b>Salvage</b>	0 mbf
<b>Export</b>	0 mbf
<b><u>Ground Base Logging:</u></b>	
<b>Percent of Sale Volume</b>	46%
<b>Average Yarding Slope</b>	30%
<b>Average Yarding Distance</b>	400 ft
<b><u>Cable Logging:</u></b>	
<b>Percent of Sale Volume</b>	54%
<b>Average Yarding Slope</b>	60%
<b>Average Yarding Distance</b>	600 ft
<b><u>Aerial Logging:</u></b>	
<b>Percent of Sale Volume</b>	0%
<b>Average Yarding Slope</b>	0%
<b>Average Yarding Distance</b>	0 ft

**Cruise**

<b>Cruise Completed</b>	May 2026
<b>Cruised By</b>	Brian Barclay
<b>Cruise Method</b>	
Variable plot cruise units and RW, 100% cruise RR unit.	

## Stumpage Computation

Species	# of Trees	Net Volume	Pond Value	(-) Profit & Risk	(-) Logging Costs	(+) Marginal Log Value	Appraised Price/MBF	Appraised Value (\$)
Douglas Fir	18,300	10,546.0	\$683.13	\$75.14	\$325.20	\$0.00	\$282.80	\$2,982,408.80
Western Hemlock	2,780	1,392.0	\$481.89	\$53.01	\$325.20	\$0.00	\$103.70	\$144,350.40
Red Alder	2,653	553.0	\$497.47	\$54.72	\$325.20	\$0.00	\$117.60	\$65,032.80
Western Redcedar	824	354.0	\$996.66	\$109.63	\$325.20	\$0.00	\$561.80	\$198,877.20
Bigleaf Maple	2,293	304.0	\$246.97	\$27.17	\$325.20	\$0.00	\$24.70 *	\$7,508.80
Grandfir	294	145.0	\$433.51	\$47.69	\$325.20	\$0.00	\$60.60	\$8,787.00
<b>Totals</b>	<b>27,144</b>	<b>13,294.0</b>						<b>\$3,406,965.00</b>

\* Minimum Stumpage values were used to compute the Appraised Price/MBF (10.00% of Pond Value)

**Percent of Volume By Log Grade**

Species	No. 1 & 2 Peeler	No. 3 Peeler	Special Mill	No. 2 Sawmill	No. 3 Sawmill	No. 4 Sawmill	Camp Run
Douglas Fir				79.0%	19.0%	2.0%	

Species	Peeler	No. 1 Sawmill	Special Mill	No. 2 Sawmill	No. 3 Sawmill	No. 4 Sawmill	Camp Run
Western Hemlock				66.0%	31.0%	3.0%	

Species	No. 1 Sawmill	No. 2 Sawmill	No. 3 Sawmill	No. 4 Sawmill	No. 5 Sawmill		Camp Run
Red Alder							100.0%

Species	No. 1 Sawmill	No. 2 Sawmill	No. 3 Sawmill	No. 4 Sawmill			Camp Run
Western Redcedar							100.0%

Species	No. 1 Sawmill	No. 2 Sawmill	No. 3 Sawmill	No. 4 Sawmill	No. 5 Sawmill		Camp Run
Bigleaf Maple							100.0%

Species	Peeler	No. 1 Sawmill	Special Mill	No. 2 Sawmill	No. 3 Sawmill	No. 4 Sawmill	Camp Run
Grandfir				79.0%	21.0%		

## Unit: 1

Species	Net	Gross Merch	Gross	# of Trees
Douglas Fir	663.0	697.0	701.0	1,152
Western Hemlock	88.0	94.0	94.0	180
Red Alder	35.0	38.0	40.0	167
Western Redcedar	22.0	26.0	26.0	50
Bigleaf Maple	19.0	20.0	20.0	142
Grandfir	9.0	10.0	10.0	19
<b>Totals:</b>	<b>836.0</b>	<b>885.0</b>	<b>891.0</b>	<b>1,710</b>

## Net Volume/Acre: 55.7 MBF

Regeneration Harvest	15.0
Partial Cut	0.0
Right of Way	0.0
<b>Total Acres:</b>	<b>15.0</b>

## Unit: 2

Species	Net	Gross Merch	Gross	# of Trees
Douglas Fir	3,759.0	3,951.0	3,971.0	6,525
Western Hemlock	497.0	531.0	531.0	990
Red Alder	198.0	217.0	226.0	948
Western Redcedar	126.0	145.0	145.0	273
Bigleaf Maple	109.0	116.0	116.0	820
Grandfir	52.0	55.0	55.0	105
<b>Totals:</b>	<b>4,741.0</b>	<b>5,015.0</b>	<b>5,044.0</b>	<b>9,661</b>

## Net Volume/Acre: 55.8 MBF

Regeneration Harvest	85.0
Partial Cut	0.0
Right of Way	0.0
<b>Total Acres:</b>	<b>85.0</b>

## Unit: 3

Species	Net	Gross Merch	Gross	# of Trees
Douglas Fir	5,984.0	6,291.0	6,323.0	10,381
Western Hemlock	789.0	843.0	843.0	1,573
Red Alder	314.0	344.0	359.0	1,505
Western Redcedar	200.0	230.0	230.0	489
Bigleaf Maple	172.0	184.0	184.0	1,302
Grandfir	82.0	87.0	87.0	167
<b>Totals:</b>	<b>7,541.0</b>	<b>7,979.0</b>	<b>8,026.0</b>	<b>15,417</b>

## Net Volume/Acre: 55.9 MBF

Regeneration Harvest	135.0
Partial Cut	0.0
Right of Way	0.0
<b>Total Acres:</b>	<b>135.0</b>

**Unit: RW2**

Species	Net	Gross Merch	Gross	# of Trees
Douglas Fir	47.0	49.0	49.0	81
Western Hemlock	6.0	7.0	7.0	12
Western Redcedar	2.0	2.0	2.0	4
Red Alder	2.0	3.0	3.0	11
Grandfir	1.0	1.0	1.0	1
Bigleaf Maple	1.0	1.0	1.0	10
<b>Totals:</b>	<b>59.0</b>	<b>63.0</b>	<b>63.0</b>	<b>119</b>

**Net Volume/Acre: 59.0 MBF**

Regeneration Harvest	0.0
Partial Cut	0.0
Right of Way	1.0
<b>Total Acres:</b>	<b>1.0</b>

**Unit: RW3**

Species	Net	Gross Merch	Gross	# of Trees
Douglas Fir	93.0	98.0	98.0	161
Western Hemlock	12.0	13.0	13.0	25
Western Redcedar	4.0	5.0	5.0	8
Red Alder	4.0	5.0	5.0	22
Bigleaf Maple	3.0	3.0	3.0	19
Grandfir	1.0	1.0	1.0	2
<b>Totals:</b>	<b>117.0</b>	<b>125.0</b>	<b>125.0</b>	<b>237</b>

**Net Volume/Acre: 58.5 MBF**

Regeneration Harvest	0.0
Partial Cut	0.0
Right of Way	2.0
<b>Total Acres:</b>	<b>2.0</b>

Total Stump To Truck	Net Volume	\$/MBF
\$1,906,616.34	13,294.0	\$143.42

**Stump to Truck: Falling, Bucking, Yarding, & Loading**

Yarding System	Unit of Measure	# of Units of Measure	\$/Unit of Measure	Total Cost	Remarks
Cable: Medium Yarder	GM MBF	7,596.0	\$155.88	\$1,184,064.48	Loads per day 9
Wheel Skidder	GM MBF	6,471.0	\$111.66	\$722,551.86	Loads per day 11
<b>Subtotal</b>				<b>\$1,906,616.34</b>	

**Additional Costs**

Item	Unit of Measure	# of Units of Measure	\$/Unit of Measure	Total Cost	Remarks
<b>Subtotal</b>				<b>\$0.00</b>	

**Additional Moves**

Equipment	Unit of Measure	# of Units of Measure	\$/Unit of Measure	Total Cost	Remarks
<b>Subtotal</b>				<b>\$0.00</b>	

Total	Net Volume	\$/MBF
\$1,055,025.00	13,294.0	\$79.36

Utilization Center	One Way Mileage	Description	Unit of Measure	# of Units	\$/Unit of Measure	Total Cost	% of Sale Volume
Eugene OR	50.0	Saw logs	GM MBF	14,067.0	\$75.00	\$1,055,025.00	100%

**Comments:**

\$125/hour X 3 hours = \$375 per trip. 5 MBF per load = \$75.00 per MBF.

**Engineering Allowances**

Total	Net Volume	\$/MBF
\$1,280,538.64	13,294.0	\$96.32

Cost Item	Total Cost
Road Construction:	\$1,075,891.87
Road Maintenance/Rockwear:	\$71,434.18
Road Use Fees:	\$133,212.59

**Comments:**

Purchaser Maint. \$56877.74, Decom. \$2968.20, Rockwear \$11588.24

Total	Net Volume	\$/MBF
\$81,032.00	13,294.0	\$6.10

### Environmental Protection

Cost item	Total Cost
Grass seed	\$600.00
Grass seed spreading	\$280.00
Basal girdle snag create	\$3,045.00
High girdle snag create	\$10,875.00
Tree topping snag create	\$17,400.00
Equipment washing	\$400.00
Snag create admin 10%	\$3,132.00
<b>Subtotal</b>	<b>\$35,732.00</b>

### Slash Disposal & Site Prep

Cost item	Total Cost
Landing pile and cover	\$1,125.00
Landing pile burn	\$1,125.00
Machine pile burn	\$10,250.00
Machine pile and cover	\$32,800.00
<b>Subtotal</b>	<b>\$45,300.00</b>

**Information for Timber Sale Notice, Prospectus, Sec. 43 & 44**  
**Golden Nectar Timber Sale**  
**ORN02-TS-2026.0203**

Approx # of trees	Est Volume MBF 32'	Species	Est Volume MBF 16'	Appraised \$/MBF	Appraised Value (\$)
18,300	8,858.0	Douglas Fir	10,546.0	\$282.80	\$2,982,408.80
2,780	1,197.0	Western Hemlock	1,392.0	\$103.70	\$144,350.40
2,653	420.0	Red Alder	553.0	\$117.60	\$65,032.80
824	280.0	Western Redcedar	354.0	\$561.80	\$198,877.20
2,293	231.0	Bigleaf Maple	304.0	\$24.70 *	\$7,508.80
294	115.0	Grandfir	145.0	\$60.60	\$8,787.00
<b>27,144</b>	<b>11,101.0</b>		<b>13,294.0</b>		<b>\$3,406,965.00</b>

\* Minimum Stumpage values were used to compute the Appraised Price/MBF (10.00% of Pond Value)

<b>CRUISED BY:</b>	Brian Barclay
<b>CRUISE COMPLETED:</b>	May 2026
<b>COMBINED SAMPLING ERROR:</b>	9.90%

<b>CRUISE DESIGN/METHOD Description:</b>
Variable plot cruise units and RW, 100% cruise RR unit.

## TRACT FEATURES

### ALL SPECIES

<b>QM DBH</b>	18.5	INCHES
<b>GM LOG</b>	95	BD FT
<b>Total Gross Volume</b>	14,149	MBF
<b>Recovery</b>	94	%
<b>Salvage</b>	0	MBF
<b>Export</b>	0	MBF

Dominant Species: **Douglas Fir**

<b>QM DBH</b>	18.8	INCHES
---------------	------	--------

<b>GM Log</b>	100	BD FT
<b>Recovery</b>	95	%
<b>Salvage</b>	0	MBF

<b>EXPORT VOLUME (LE-1)</b>	Port Orford Cedar	0	MBF
-----------------------------	-------------------	---	-----

<b>Reserve Tree Paint Color</b>	<b>Reserve Tree Count</b>
	0

<b>Harvest Tree Paint Color</b>	<b>Harvest Tree Count</b>
	0

UNITED STATES  
DEPARTMENT OF THE INTERIOR  
BUREAU OF LAND MANAGEMENT

Version: 8.0.0.33  
Updated: 11/4/2022

**Summary of All Roads and Projects**

T.S. Contract Name: Golden Nectar    Tract No: 2026.0203    Sale Date: July 2026  
Prepared by: C. Young    Ph: 5039834864    Print Date: 5/26/2026 1:58:32 PM  
Construction: 65.35 sta  
Improve: 51.74 sta    Renov: 412.89 sta    Decom: 0.00 sta    Temp: 0.00 sta

200 Clearing and Grubbing: 8.49 acres .....	\$31,248.21
300 Excavation: 20277 cy .....	\$124,231.77
Haul < 500 ft: 0 sta-yds	
Haul > 500 ft: 0 yd-mi	
400 Drainage: .....	\$121,548.40
Culvert: 420.00 lf                      DownSpout: 40.00 lf	
PolyPipe: 1,200.00 lf	
500 Renovation: .....	\$15,021.67
Blading 8.48 mi	
700-1200 Surfacing: .....	\$718,799.89
Commercial Quarry Name: Rickard 1 1/2"    698.00 LCY	
Commercial Quarry Name: Rickard 3"minus    10,004.00 LCY	
Commercial Quarry Name: Rickard 3/4    430.00 LCY	
Commercial Quarry Name: Rickard Pit Run    5,732.00 LCY	
Commercial Quarry Name: 3"Open    1,590.00 LCY	
1300 Geotextiles: .....	\$0.00
1400 Slope Protection: .....	\$0.00
1800 Soil Stabilization: 16.94 acres .....	\$16,909.34
1900 Cattleguards: .....	\$0.00
2100 RoadSide Brushing: .....	\$7,734.93
Mechanical Brushing: 16.14 acres	
2300 Engineering: 0.00 sta. ....	\$0.00
2400 Minor Concrete: .....	\$0.00
2500 Gabions: .....	\$0.00
8000 Miscellaneous: .....	\$7,228.16
Mobilization: Const. \$25,941.50    Surf. \$7,228.00.....	\$33,169.50
Quarry Development: .....	\$0.00
Total: 13,294 mbf @ \$80.931/mbf =	
	\$1,075,891.87

Notes:

Quantities shown are estimates only and not pay items.  
Surfacing Quantities are loose cubic yards.

UNITED STATES  
 DEPARTMENT OF THE INTERIOR  
 BUREAU OF LAND MANAGEMENT

Sale: Golden Nectar  
 Sale Date: July 2026  
 Prep. By : C. Young  
 Tract No: 2026.0203

ROAD MAINTENANCE AND ROAD USE APPRAISAL WORK SHEET

Summary of Costs

1.1) Road Use - Amortization: 133,212.59/13294 MBF = \$10.02/MBF

---

Road Maintenance Obligation:

(2.1) BLM Maintenance . . . . .		\$0.00
(2.2) BLM Rockwear . . . . .	\$11,588.24	
(5.1) Purchaser Maintenance Rockwear . . . . .	<u>\$0.00</u>	
Total Rockwear Payable to BLM . . . . .		\$11,588.24
(3.1) 3rd Party Maintenance . . . . .		\$0.00
(3.2) 3rd Party Rockwear . . . . .		\$0.00
(4.1) Other Maintenance Payments . . . . .		\$0.00
Total Maintenance Fee Obligation (2.1-5.1)		<u>\$11,588.24</u>

Purchaser Maintenance Allowances:

(5.2A) Move In . . . . .		\$4,413.00
(5.2B) Culverts, Catch Basins, Downspouts . . . . .		\$5,166.78
(5.2C) Grading, Ditching . . . . .		\$9,393.80
(5.2D) Slide Removal and Slump Repair . . . . .		\$1,834.16
(5.2E) Dust Palliative (Water) . . . . .		\$0.00
(5.2F) Surface Repair (Aggregate) . . . . .		\$33,570.00
(5.2G) Other . . . . .		\$2,500.00
Total Purchaser Maintenance Allowances (5.2A-5.2G)		<u>\$56,877.74</u>

(2.1-5.2G) Cost (\$11,588.24 + \$56,877.74) = \$68,465.98  
 Cost/MBF 68465.98 / 13294 MBF = \$5.15/MBF

(5.2H) Decommissioning . . . . . \$2,968.20

(5.2H) Cost/MBF \$2,968.20/13294 MBF = \$0.22/MBF

(2.1-5.2H) Cost (\$11,588.24 + \$56,877.74 + \$2,968.20) = \$71,434.18

Total Cost/MBF (Excluding Road Use) \$71,434.18/13294 MBF = \$5.37/MBF



UNITED STATES DEPARTMENT OF THE INTERIOR  
 Bureau of Land Management  
**Timber Sale Vicinity Map**  
 T. 14 S., R. 7 W., Section 3 W.M.

Golden Nectar  
 ORN02-TS-2026.0203

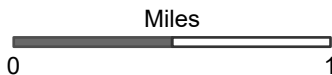
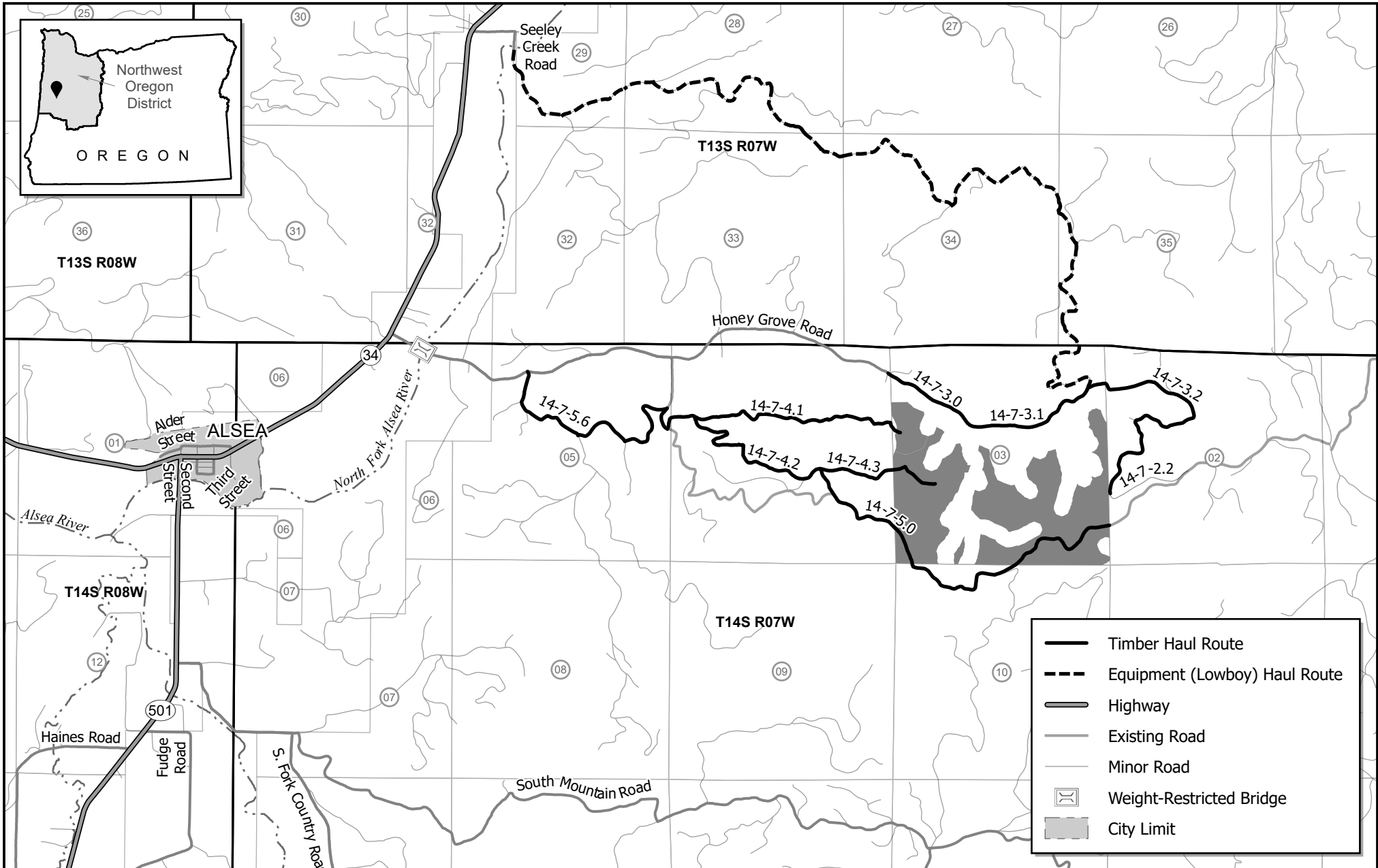

No warranty is made by the Bureau of Land Management as to the accuracy, reliability or completeness of these data for individual use or aggregate use with other data. Original Data was compiled from multiple source data and may not meet U.S. National Mapping Accuracy Standard of the Office of Management and Budget. 6/15/2026