

PLAN OF DEVELOPMENT

Golden Currant Solar Project N-100225

Prepared for
U.S. Department of the Interior
Bureau of Land Management
Las Vegas Field Office

Submitted by
Noble Solar LLC

Revised on:
June 08, 2022

CONTENTS

Contents	i
Section 1	1-4
Project Description.....	1-4
1.1 Introduction.....	1-4
1.1.1 Type of Facility, Planned Uses, Generation Output	1-4
1.1.2 Applicant’s Schedule for the Project	1-4
1.2 Proponent’s Purpose and Need for the Project	1-5
1.2.1 Need for Renewable Energy	1-5
1.2.2 Project Purpose and Need	1-6
1.2.3 Power Market and Project Benefits	1-7
1.3 General Facility Description, Design, and Operation.....	1-7
1.3.1 Project Location, Land Ownership, and Jurisdiction.....	1-7
1.3.2 Legal Land Description.....	1-8
1.3.3 Total Acreage and General Dimensions of All Facilities and Components	1-10
1.3.4 Project Elements.....	1-10
1.3.5 Project Facilities	1-11
1.3.6 Linear Facilities.....	1-23
1.3.7 Interconnection Facilities.....	1-24
1.3.8 Water and Wastewater	1-24
1.3.9 Lighting.....	1-25
1.3.10 Waste and Hazardous Materials Management	1-25
1.3.11 Fire Protection.....	1-26
1.3.12 Health and Safety Program.....	1-27
1.3.13 Stormwater Management.....	1-27
1.3.14 Vegetation Management.....	1-28
1.4 Alternatives	1-29
1.5 Other Potential Permits and Authorizations.....	1-29
1.6 Financial and Technical Capability of the Applicant.....	1-31
Section 2	2-1
Construction of the Facilities.....	2-1
2.1 Overview	2-1
2.2 Temporary Construction Workspace, Laydown and Mobilization Areas.....	2-1
2.3 Site Preparation.....	2-2
2.3.1 Land Surveying and Staking.....	2-2
2.3.2 Vegetation Removal and Treatment	2-2
2.3.3 Site Clearing, Grading, and Excavation.....	2-2
2.3.4 Gravel, Aggregate, and Concrete Needs and Sources	2-3
2.4 PV Solar Array Assembly and Construction	2-3
2.5 Electrical Collection and Transmission System Construction	2-4
2.5.1 Standard Transmission Line Construction Techniques.....	2-4

2.6	Road System Construction	2-5
2.7	Substation Construction	2-5
2.8	Site Stabilization, Protection, and Reclamation	2-6
2.9	Workforce, Schedule, Equipment, and Materials.....	2-6
2.10	Construction Traffic	2-10
2.11	Construction Power.....	2-10
Section 3		3-1
Related Facilities and Systems		3-1
3.1	Transmission System Interconnect.....	3-1
3.1.1	Proposed Transmission System	3-1
3.1.2	Ancillary Facilities.....	3-1
3.1.3	Status of Power Purchase Agreements.....	3-1
3.1.4	Status of Interconnection Agreement	3-1
3.1.5	General Design and Construction Standards	3-1
3.2	Gas Supply Systems	3-1
3.3	Other Related Systems	3-2
3.3.1	Communication System Requirements.....	3-2
Section 4		4-1
Operation and Maintenance.....		4-1
4.1	Operation and Maintenance.....	4-1
Section 5		5-1
Environmental Considerations		5-1
5.1	Site Characteristics and Potential Environmental Issues	5-1
5.1.1	Potential Resource Conflicts	5-2
5.2	Other Uses on the Project Site.....	5-4
5.2.1	Military Aviation.....	5-4
5.3	Design Features	5-4
5.4	Mitigation Measures.....	5-5
Section 6		6-1
References.....		6-1

Figures

Figure 1-1 Project Location Map..... 1-9
Figure 1-2 Typical Array Configurations 1-12
Figure 1-3 Typical Mounting System..... 1-13
Figure 1-4 Photographs of a Typical Power Conversion Station/ Inverter 1-15
Figure 1-5 Photograph of a Typical Photovoltaic Combining Switchgear..... 1-16
Figure 1-6 34.5 Kv Distribution Pole 1-16
Figure 1-7 Example of a Similar Substation Layout..... 1-17
Figure 1-8 Photograph of a Batter Energy Storage System (BESS) and DC/DC Converter1-18
Figure 1-9 Example of Security Fencing..... 1-19
Figure 1-10 Operation and Maintenance Building Layout 1-19
Figure 1-11 Access Roads Within Project Boundary.....1-21

Figure 1-12 Typical 230 Kv Double Circuit Monopole for Gen-Tie Support Structures.. 1-22
Figure 1-13 Typical Sections of Drainage Features 1-26
Figure 1-14 Representative Vegetation Heights During Construction and Maintenance 1-27

Tables

Table 1-1 Applicant’s Project Schedule..... 1-5
Table 1-2 Township/Range and Section Information..... 1-8
Table 1-3 Summary of Permanent and Temporary Disturbance..... 1-10
Table 1-4 Wastes Potentially Generated by the Project 1-19
Table 1-5 Hazardous Materials That May Be Used During Operation 1-21
Table 1-6 Federal, State, and Local Permits and Authorizations..... 1-24
Table 2-1a Estimated On-site Equipment for Solar Panel Array and Collection System Construction 2-7
Table 2-1B Estimated On-site Equipment for substation Construction 2-9
Table 2-1C Estimated On-site Equipment for Gen-Tie Line Construction 2-9
Table 4-1 Routine Maintenance Protocol..... 4-3

Attachment A Preliminary Site Plan

SECTION 1

Project Description

1.1 Introduction

1.1.1 Type of Facility, Planned Uses, Generation Output

Noble Solar LLC (Applicant) proposes to construct, own, operate, and decommission the Golden Currant Solar Project (Project), consisting of up to a nominal 400-megawatt (MW) alternating current (MWac) solar photovoltaic (PV) power generating facility and 400-megawatt (MW) Battery Energy Storage System (BESS) on Bureau of Land Management (BLM)-administered land located in Clark County, Nevada. The Project would be constructed using photovoltaic solar modules mounted on single-axis, horizontal tracker structures.

The Project will be located on approximately 4,364 acres of BLM administered land. The ROW application contains a larger area than required for the solar field to allow for adjustments in the facility layout to minimize environmental impacts, based on the National Environmental Policy Act (NEPA) analysis.

The power produced by the Project would be conveyed to the NV Energy (“NVE”) transmission system or the California ISO transmission system (“CAISO”) via a 2.1 mile long 230 kV overhead Gen-Tie to the Trout Canyon 230 kV substation where the project holds an interconnection queue position.

Average annual energy production from a 400 MWac Project equates to the annual daytime electricity needs of approximately 230,000 households. Solar electric power is produced during daylight hours when electricity demand is highest which will be coupled battery energy storage technology in order to improve the customer’s energy product. The Project would generate greenhouse gas-free electricity that would offset approximately 860,000 metric tons of carbon dioxide and other emissions that would result from producing an equivalent amount of electricity from fossil fuel-fired electric generators.

1.1.2 Applicant’s Schedule for the Project

The BLM would be the lead federal agency for approving the Project and would issue a ROW grant authorizing the use of BLM-administered lands for Project construction, operation, and decommissioning. The project site is within a “variance area” for solar power plant development, as defined in the Record of Decision prepared for the Final Programmatic Environmental Impact Statement (EIS) for Solar Energy Development in Six Southwestern States (Solar PEIS). Utility-scale solar energy development projects in variance areas is permitted subject to site-specific

conditions. All such projects are required to comply with the National Environmental Policy Act (NEPA) and other applicable laws. Preparation of an EIS is expected to be required; the completion of the EIS process and issuance of a ROD is targeted for the Second Quarter 2023. Further detail on the project schedule is provided in **Table 1-1**.

Prior to any activity on the site, required resource management plans would be developed and approved, and regulatory and permit conditions would be integrated into the final construction compliance documents. Project construction would begin once all applicable approvals and permits have been obtained. Construction is expected to take approximately 12 months and would include the major phases of mobilization, construction grading and site preparation, installation of drainage and erosion controls, PV panel/tracker assembly, and solar field construction. Once construction is completed, the Project would be in operation for at least 30 years with the possibility of a subsequent repowering for additional years of operation.

TABLE 1-1 APPLICANT’S PROJECT SCHEDULE

Activity	Date
BLM Permitting/NEPA (EIS) Process Complete	4th Quarter 2023
Construction Commencement	4th Quarter 2024
Startup and test	4th Quarter 2025
Commercial operation	December 31, 2025

1.2 Proponent’s Purpose and Need for the Project

1.2.1 Need for Renewable Energy

The United States has a greater solar energy resource potential than any other industrialized nation. The multiple benefits associated with developing this resource have been recognized repeatedly by both federal and state policy-makers. Development of solar resources reduces reliance on foreign sources of fuel, promotes national security, diversifies energy portfolios and contributes to the reduction of greenhouse gas emissions. The demand for power continues to grow in the Western United States. As older technology fossil-fuel plants reach the end of their useful lives, there is a need to replace them with clean, reliable resources. Recognizing this need, many Western states, including Nevada, have enacted legislation to encourage or mandate the development of renewable generation.

Nevada’s Renewable Portfolio Standard (RPS) requires 50% of all electricity generated in Nevada be derived from renewable sources by 2030. State government agencies were directed to take all appropriate actions to implement this target in all regulatory proceedings, including siting, permitting, and procurement for renewable energy power plants and transmission lines. The RPS in Nevada and other states has created a competitive market for contracts to sell renewable energy, with success determined on the basis of “least cost, best fit” criteria.

Nevada has passed legislation requiring utilities to phase out their use of coal-fired generation and partially replace that generation with renewable energy, as well as legislation that amended the

existing RPS laws, resulting in requirements for utilities to increase their use of renewable energy (SB 123, SB 252). In order to achieve these goals, it is necessary to build new renewable energy facilities, including substantial solar energy facilities such as the proposed Project. The Applicant believes that the Project would generate electricity that is cost-competitive with electricity from other types of renewable projects.

The federal government has enacted legislation strongly encouraging the development of renewable energy. As part of an overall strategy to develop a diverse portfolio of domestic energy supplies for our future, the National Energy Policy of 2001 and the Energy Policy Act of 2005 (Public Law 109-58, August 8, 2005) encourage the development of renewable energy resources, which includes solar energy. Section 211 of the Energy Policy Act of 2005 encourages the approval of at least 10,000 MW of non-hydropower renewable energy production on the public lands; this goal was met in 2012. In early 2009, the Secretary of the Interior issued Orders 3283 and 3285, making the production, development, and delivery of renewable energy top priorities for the Department of the Interior. The President's Climate Action Plan, released on June 25, 2013, sets forth a new goal for the Department of the Interior to approve 20,000 MW of renewable energy projects on the public lands by 2020. Congress is also considering legislation that would implement greenhouse gas emissions requirements and/or national renewable portfolio standards.

Part of the government's efforts to promote renewable energy depend on the ultimate development of increasingly economical facilities that drive down the price of renewable energy, and ultimately enable it to compete in the market place with fossil fuel facilities.

1.2.2 Project Purpose and Need

The fundamental purpose of the Project is to construct a clean, renewable source of solar electricity that helps meet the region's growing demand for power and helps fulfill national and state renewable energy and greenhouse gas emission goals. Solar energy provides a sustainable, renewable source of power that helps reduce fossil fuel dependence and greenhouse gas emissions. Considering the entire process, from raw material sourcing through end-of-life-cycle collection and recycling, 400MWac of additional generating capacity would produce a small fraction of the greenhouse gas emissions of a similar capacity fossil fuel plant.

Specific Project objectives are:

- Establish a solar PV power-generating facility that is of sufficient size and configuration to produce approximately 400 MWac of electricity in order to provide Nevada a significant new source of renewable energy.
- Produce and transmit electricity at a competitive cost.
- Initiate construction of the Project during calendar year 2023 in order to qualify for the federal solar Investment Tax Credit (ITC).
- Locate the facility in the rural part of Clark County in proximity to an available connection to the upgraded NVE electrical distribution infrastructure.
- Minimize environmental effects by:

- Avoiding Exclusion Areas identified in the Solar PEIS ROD;
- Using existing electrical distribution facilities, rights-of-way, roads and other existing infrastructure where practicable;
- Minimizing water use during operation;
- Reducing greenhouse gas emissions.
- Using solar technology that is available, proven, efficient, and easily maintained, recyclable, and environmentally sound.

1.2.3 Power Market and Project Benefits

The Project would interconnect to NVE or CAISO using existing transmission lines. The interconnection would allow regional customers to purchase renewable energy generated by the Project under one or more Power Purchase Agreements (PPAs) to deliver energy from a (nominal) 400 MWac generating facility.

The Project is well suited to arid environments because of the technology’s low water consumption. This is a key consideration in Nevada and the Western U.S., as the population grows and water supplies become more constrained. PV solar technology, which converts sunlight directly into electrical energy, entails no thermal process, and therefore does not require process or cooling water to produce electricity. Water consumption during operations would consist of dust control and domestic use for on-site personnel and is between 95 and 99 percent less than concentrating solar projects that employ conventional steam turbines to generate electricity.

The Project would also create employment for Nevada residents. The Project is anticipated to create an average of 1,000 construction jobs at any given time, and create up to 20+ long-term full-time-equivalent (FTE) operational jobs. These jobs would in turn support many other jobs in the Nevada economy.

1.3 General Facility Description, Design, and Operation

1.3.1 Project Location, Land Ownership, and Jurisdiction

The Project site is located in Clark County, Nevada, approximately 5 miles southeast of Pahrump and 26 miles west of Las Vegas. State Route 160 is less than 2 miles northeast of the site.

The Project is located entirely on federal lands administered by the BLM under the 1998 Las Vegas Resource Management Plan. The Project site is located within a variance area for solar power generation under the 2012 Approved Resource Management Plan Amendments/Record of Decision for Solar Energy Development in Six Southwestern States.

1.3.2 Legal Land Description

The Project is located on the property identified in the table below, all located within the Mount Diablo Base and Meridian. Specific township/range and section information is shown in **Table 1-2**.

TABLE 1-2 TOWNSHIP/RANGE AND SECTION INFORMATION

Township	Range	Sections	Description
22S	55E	02	NWSW; SWNW; SWSW
		03	SESE; NESE
		07	Lots 3, 4; E2SW; SE
		08	S2
		09	S2
		10	NENE; NWNE; NWSE; SWNE; SENW; NESW; SESW; SWSW
		15	NWNW
		16	NW; NE; SW; W2SE; NESE
		17	ALL
		18	ALL
		19	ALL
		20	ALL
		21	NW; NWSW
		29	NW; NWNE; NENE; SWNE
		30	Lot 1; NENW; NE

FIGURE 1-1 PROJECT LOCATION AND GEN-TIE MAP

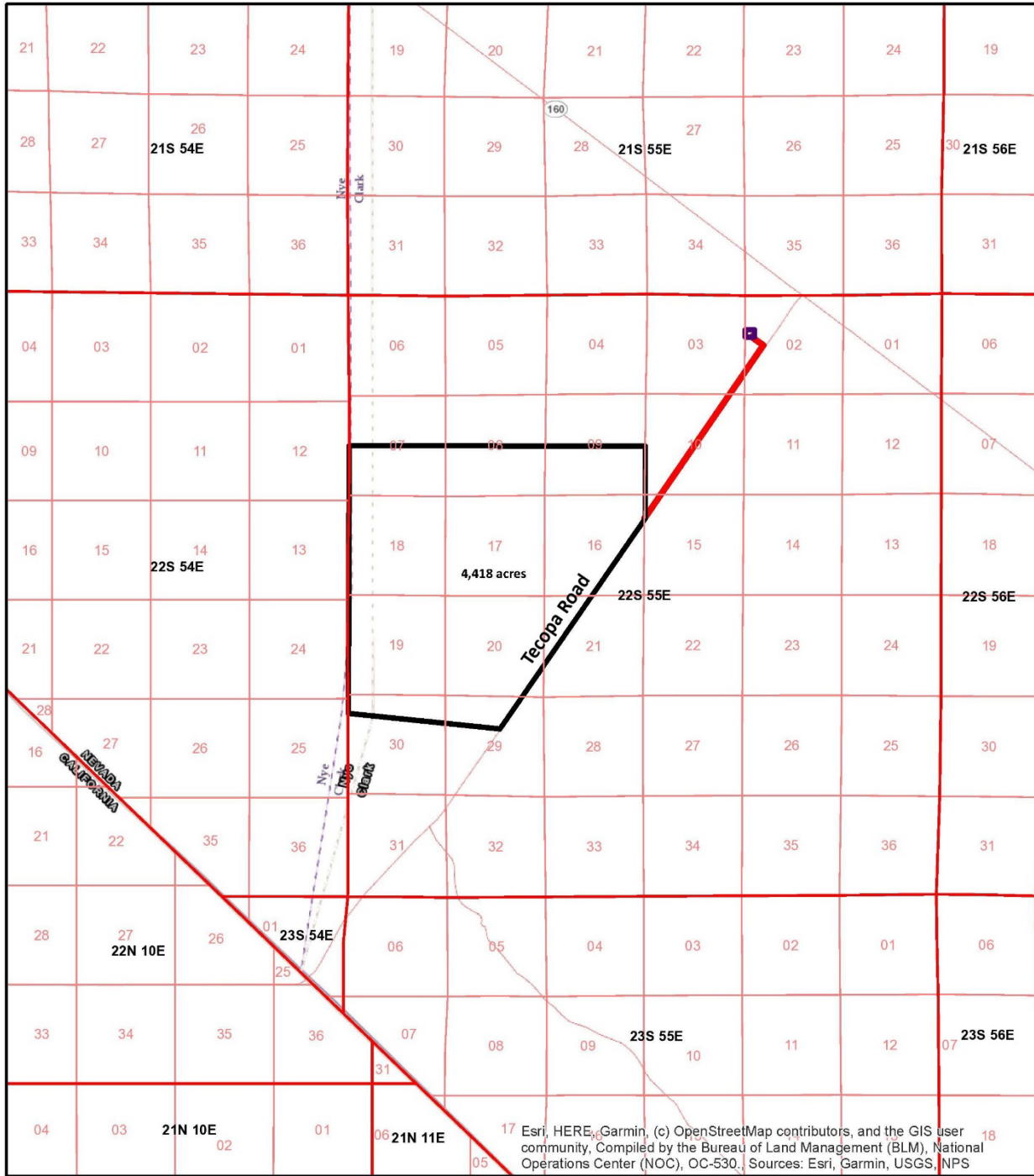

Golden Current Project Location and Gen-Tie Map

4,418 Acres on BLM Lands
 Clark County, Nevada

0 0.5 1 2 3 4 Miles

- Project Boundary
- Gen-Tie (2.1 mi)
- Trout Canyon Substation

ENERGY PROJECT SOLUTIONS

Author: Sean Rhoads

1.3.3 Total Acreage and General Dimensions of All Facilities and Components

Table 1-3 lists Project facilities and the associated permanent and temporary disturbance acreages. The proposed site plan is provided in Attachment 1.

TABLE 1-3 SUMMARY OF PERMANENT AND TEMPORARY DISTURBANCE

Disturbance Type	Acres Disturbance	of	Notes
------------------	----------------------	----	-------

Permanent Disturbance

Solar facility	4,418		400 MWac PV solar facility and 400 MWac BESS.
Collection line road	5.09		Up to 20 feet wide and 2.1 miles in length. Pole sites included.
Total	4,423.09		

Temporary Disturbance

Transmission line construction	38.18		150 feet by 2.1 miles
Total	38.18		

Total Proposed ROW Acreage	4,522		
-----------------------------------	--------------	--	--

1.3.4 Project Elements

The Project would include the following primary elements (see Attachment 1):

- Solar array blocks consisting of solar photovoltaic modules mounted on single-axis, horizontal tracker mounting systems supported by driven steel posts or other embedded foundation design;
- Direct current (DC) collection system and Power Conversion Stations (PCSs) to collect power from the array blocks;
- Overhead 34.5 kV AC collection system to convey electricity from the PCSs to the substation;
- Energy storage system;
- An internal roadway system consisting of spoke, ring, and perimeter roadways;
- Access roads along Project generation tie (gen-tie) lines, if needed for line maintenance, up to 20 feet (6.1 meters) wide with an aggregate surface;
- One to three additional on-site switchyards hosting on-site ringbus switchyard(s);

- Generation tie-line extending from the project switchyard(s) to the Trout Canyon 230 kV substation, consisting of one 230 kV circuit with 150 foot right-of-way width;
- Administrative and maintenance buildings;
- Redundant telecommunication systems and cables installed in tandem with the gen-tie routes. Microwave and wireless systems also onsite;
- Meteorological towers (steel monopole), approximately 30 feet high, mounted on concrete foundations may be installed around the perimeter of the solar field;
- Project security using a combination of perimeter security fencing, controlled access gates, onsite security patrols, lighting, electronic security systems and/or remote monitoring;
- A 10-foot wide firebreak outside the perimeter fence;
- Drainage control structures, final design to be determined upon completion of a hydrologic study;
- A temporary construction mobilization and laydown area, which would contain construction trailers, construction workforce parking, above ground water tanks, materials receiving, and materials storage (graded/compacted earth) within the project boundary.

1.3.5 Project Facilities

The Project would be designed in accordance with federal, state, and industrial standards, including American Society of Mechanical Engineers standards, National Electrical Safety Code, International Energy Conservation Code, International Building Code, Uniform Plumbing Code, Uniform Mechanical Code, National Fire Protection Association, and Occupational Safety and Health Administration regulations.

1.3.5.1 Solar Panel Arrays

The proposed Project would utilize high-efficiency commercially available solar PV modules that are Underwriters Laboratory (UL)-listed or approved by another nationally recognized testing laboratory. Materials commonly used for solar PV modules include monocrystalline silicon, polycrystalline silicon, amorphous silicon, cadmium telluride (CdTe), and copper indium selenide/sulfide.

The project would use monocrystalline or polycrystalline silicon solar PV modules mounted on single-axis, horizontal tracker mounting systems. Mounted PV modules, inverters, and transformers would be combined to form array blocks, approximately 2 MW in size.

With a horizontal tracker mounting system, the panel arrays are arranged in north-south oriented rows and drive motors would rotate the horizontally mounted solar panels from east to west to follow the sun (on a single axis) throughout the day. A typical panel array layout using horizontal trackers is shown in Figure 1-2. The highest point for a horizontal tracker would be achieved during the morning and evening hours when the trackers are tilted at their maximum angle, and would be a maximum of 12 feet above the ground surface depending on the grade where the posts are installed (**Figure 1-3**). When solar modules are roughly parallel to the ground, the overall height

of the tracker unit would be a maximum of 6 feet above the ground surface depending on the grade where the posts are installed.

FIGURE 1-2 TYPICAL ARRAY CONFIGURATIONS

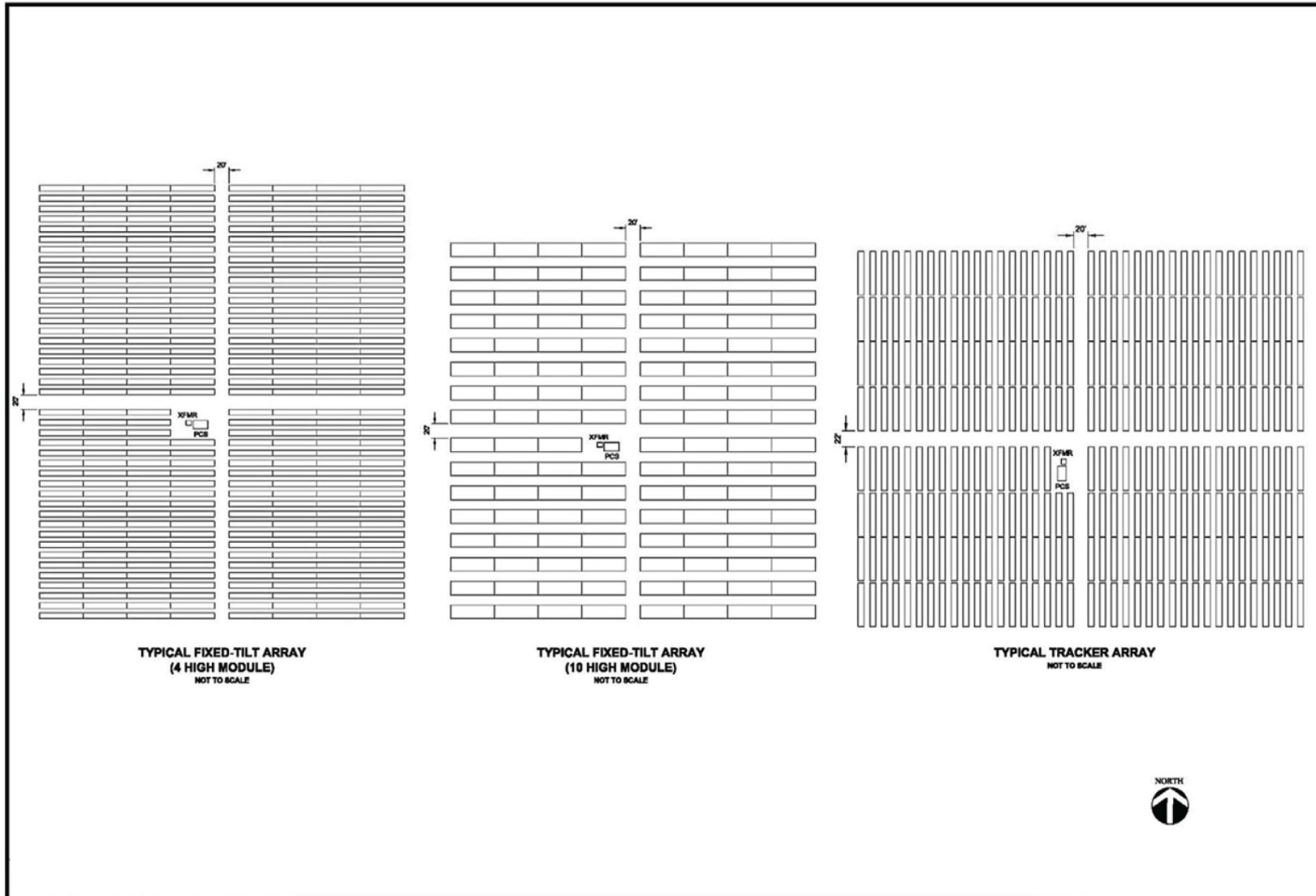
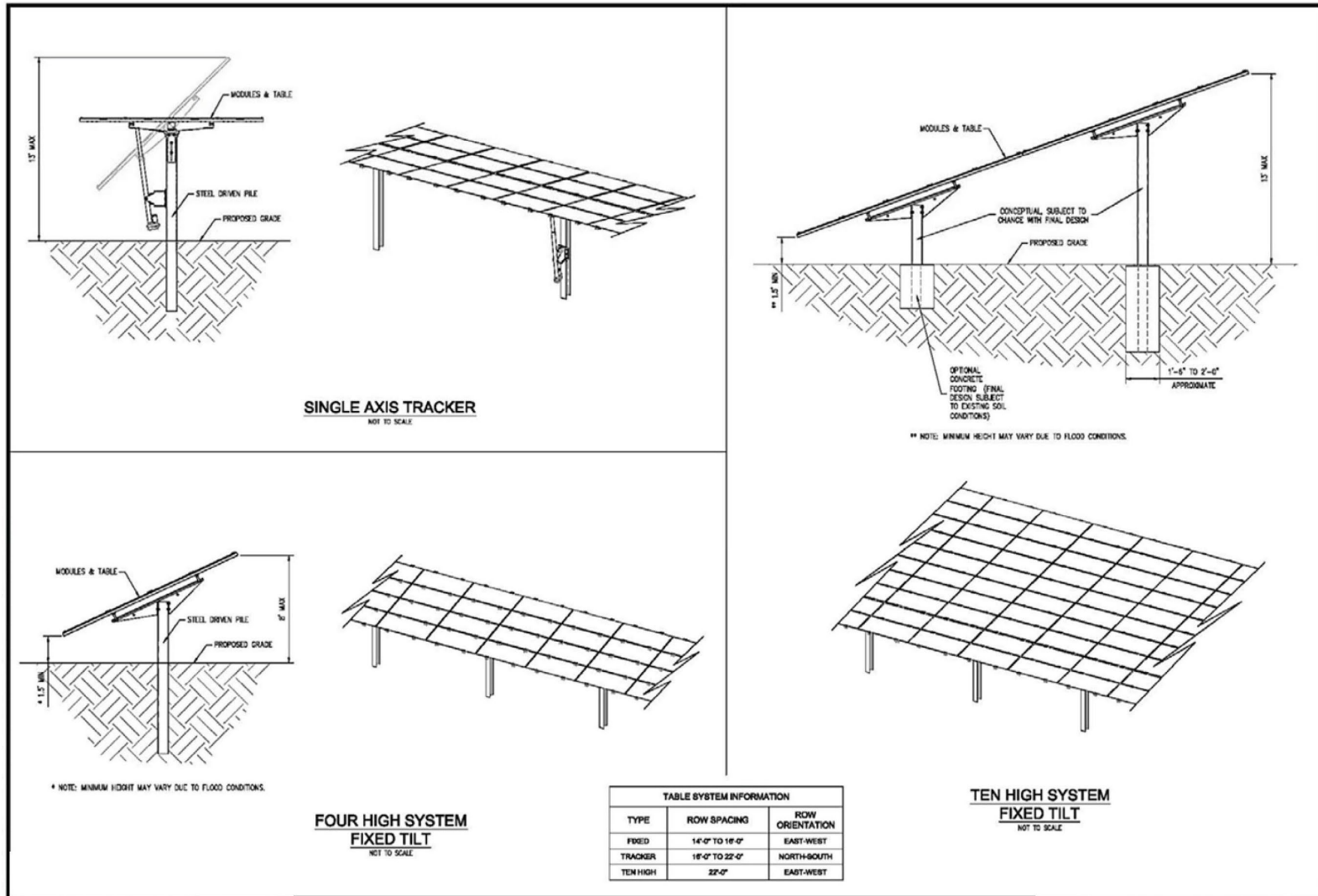

FIGURE 1-3 TYPICAL MOUNTING SYSTEM



The vertical support legs for the tracker mounting system consists of foundations that may include concrete piers approximately 18 to 24 inches in diameter and 6 to 8 feet deep, or driven posts (wide flange I-beam) approximately 6 to 8 inches across and 6 to 12 feet deep. The preferred mounting configuration would use directly embedded driven posts; concrete piers would be used only if subsurface conditions do not support driven posts.

In this type of system, each tracker panel array is approximately 285 feet long and powered by a low-voltage solar-powered drive motor. The motors and actuator are mounted to one of the driven posts and do not require separate foundations for mounting. Hydraulic drive systems would not be used. The motors only would be operated for a few seconds every 5 to 10 minutes during daylight conditions to move the panels in approximately 1 degree increments. The sound from the tracker motors would be less than 70 decibels at a distance of 3 feet. This would equate to less than 30 decibels at 50 feet.

Meteorological stations located at the site would monitor wind speed and communicate with the tracker units. This would allow for the trackers to rotate to a flat position during high wind activity. The meteorological station towers would be located at multiple locations around the perimeter of the solar array. Meteorological station towers would be a monopole design and would not exceed 30 feet in height. Each tower would require a small concrete foundation approximately 3 feet by 3 feet that would extend approximately 4 feet into the ground, depending on soil conditions.

Emergency Backup Power

If horizontal trackers are used, the PCSs would be equipped with emergency backup power required to rotate the tracker units to their stow position in the unlikely event of high winds and a loss of the primary electrical connection from the Project to the transmission system. The emergency back-up power system would consist of a 15 kilovolt-ampere (kVA) battery-based uninterruptible power supply (UPS) at each PCS.

1.3.5.2 Electrical Collection System

PV modules convert sunlight into DC electricity. One or more combiner boxes would be located in the array block to collect the DC electricity from PV modules. The electricity would be delivered through underground cables to an inverter that changes the DC electricity to AC electricity and a medium-voltage transformer that steps up the voltage to 34.5 kV. This converted electricity then would be delivered to an onsite substation, where the electricity again would be stepped up to 230 kV for delivery to the transmission grid.

Inverters, Transformers, and Medium Voltage Switchgear

Each array block would have a Power Conversion Station (PCS) containing inverters and medium voltage transformers, as well as other electrical equipment (**Figure 1-4**). Each PCS also would contain communication equipment to wirelessly communicate with the tracker units to control operation and detect anomalous conditions. Photovoltaic Combining Switchgear, or PVCS, will be located along the 34.5 kV collector line (**Figure 1-5**). All electrical equipment would be housed in protective enclosures on concrete pads.

FIGURE 1-4 PHOTOGRAPHS OF A TYPICAL POWER CONVERSION STATION/ INVERTER



Source: (Luminous Energy n.d.)



Source: (Fotowatio Renewable Ventures 2017)

FIGURE 1-5 PHOTOGRAPH OF A TYPICAL PHOTOVOLTAIC COMBINING SWITCHGEAR



Source: (APT n.d.)

34.5 kV Collection System

The 34.5 kV collection system would comprise both underground and overhead cabling. From the medium-voltage transformers to the PVCSSs, the 34.5 kV system would be installed underground using 35 kV-rated medium voltage cables listed for direct buried applications except that overhead cabling would be installed where necessary to avoid existing underground facilities. Underground 34.5 kV cables would be installed to comply with the minimum burial depth in accordance with the National Electrical Code.

From the PVCSSs to the onsite substation, the 34.5 kV system would be installed overhead. Overhead 34.5 kV collector lines would be installed as double circuit lines on wood monopoles with post insulators (typical of medium voltage installations in electric distribution systems) (Figure 1-6). Pole height would be up to 75 feet above grade.

FIGURE 1-6 34.5 KV DISTRIBUTION POLE

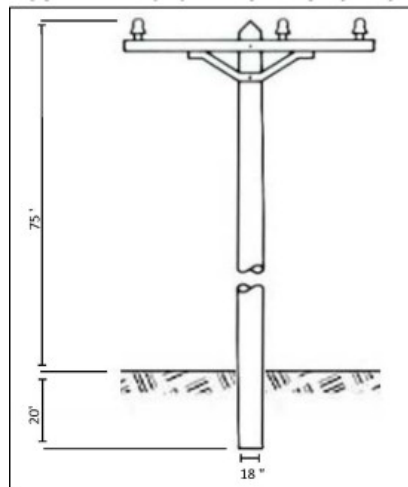

Substations

A 2.5-acre 230 kV Substation would be developed within the project site. Individual 35 kV “Circuits” will feed approximately 10 blocks each. Substation would be constructed based on applicable electrical safety codes. The substation would be separately fenced to provide increased security around the medium and high voltage electrical equipment. The substation area would include a transformer containment area, a microwave tower, a control house, and one or more transformers as shown in **Figure 1-7**. Containment measures for all substation equipment shall be provided in accordance with Environmental Protection Agency 40 CFR Part 112 and all applicable codes required by the local, state, and federal governing authorities. The transformer containment area would be lined with an impermeable membrane covered with gravel, and would include a drain with a normally closed drain valve. Transformers will be provided with secondary oil containment equal to 110% of the volume of oil present in the transformer in addition to the volume of rain water for a 25-year, 24-hour rainfall event.

FIGURE 1-7 EXAMPLE OF A SIMILAR SUBSTATION LAYOUT

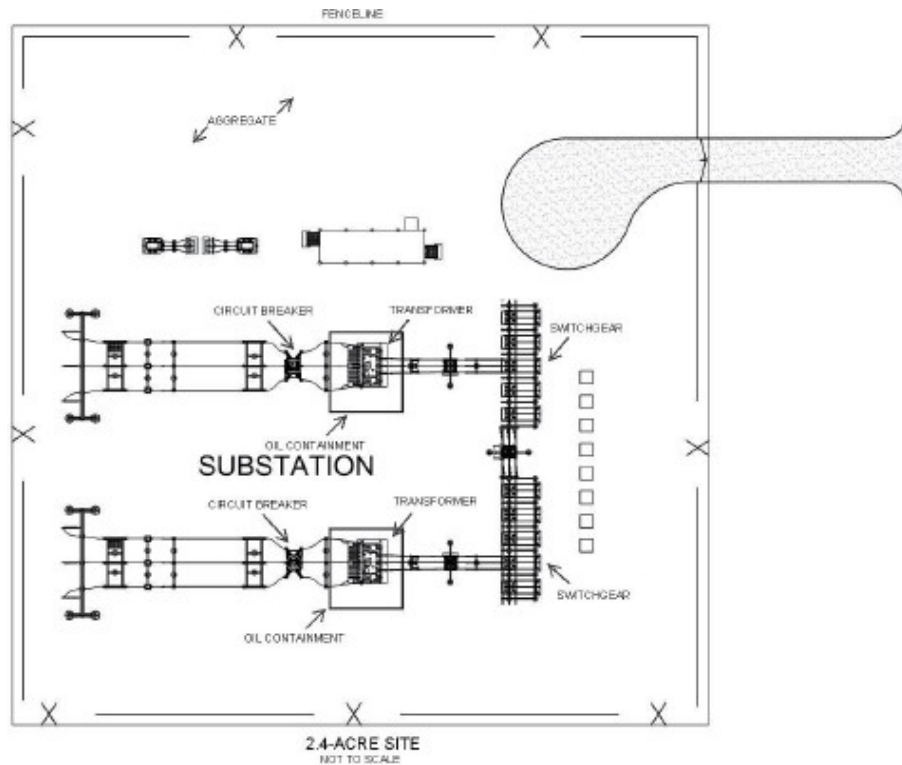

1.3.5.3 Energy Storage

A battery energy storage system (BESS) would be located within the site (**Figure 1-8**). Approximately 400 MW of battery systems will be installed at the project, with each battery system installed at an inverter.

FIGURE 1-8 PHOTOGRAPH OF A BATTERY ENERGY STORAGE SYSTEM (BESS) AND DC/DC CONVERTER



1.3.5.4 Site Security and Fencing

Security at the Project site would be achieved by fencing, lighting, security patrols, and electronic security systems. The Project site would be monitored 24 hours per day, seven days per week during all phases. Lighting would be provided at the O&M building and Project entrance gate. The solar field and support facilities perimeter would be secured with chain link metal-fabric security fencing as shown in **Figure 1-9**. Controlled access gates would be located at the site entrance as shown in **Figure 1-10**. The perimeter fence would be an approximately 6- to 7-foot-high chain link fence with 1-foot-high barbed-wire security strands at the top; a 10-foot-wide fire break would be maintained around the exterior of the perimeter fence (the security fence in proximity to the gen-tie line would be properly grounded).

FIGURE 1-9 EXAMPLE OF SECURITY FENCING



Source: (Phoenix Biological Consulting, Inc. 2018b)

FIGURE 1-10 OPERATION AND MAINTENANCE BUILDING LAYOUT

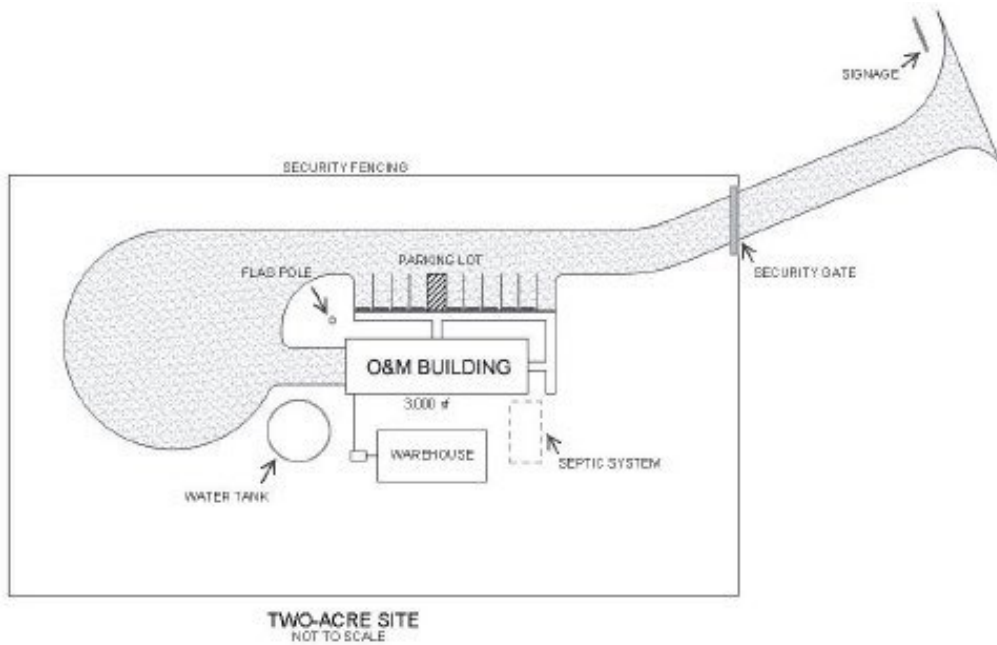

1.3.5.5 Internal Project-Related Roads

Project-related roads within the solar facility will include the perimeter roads around development areas which will be located within the project fenceline, and solar field internal access roads. Similar to the disturbance that would occur from other Project components (based on the assumption that all acreage within the fenced perimeter would be disturbed), the acreage identified

for roads also is considered to be permanent disturbance. These internal access roads will be built to provide vehicle access to the solar equipment (PV modules, inverters, transformers) for O&M activities. Access roads will be approximately 20 feet (6.1 meters) wide and will be composed of native graded and compacted soils, and a preliminary road layout is shown in **Figure 1-11**. Alternatively, they may use a BLM approved aggregate base in some or all areas to meet Project dust and flood control requirements. If required, the existing surface area of the access roads will be cleared and compacted using on-site materials. Some internal access roads may be constructed with aggregate; however, most internal roads will be constructed using only recompacted native materials. Where aggregate is needed (either due to high usage or necessary based on the need to facilitate drainage and minimize dust or erosion) approximately 4 to 6 inches (10 to 15 centimeter) of BLM-approved aggregate is applied over compacted native soils. The design standard for the access roads within the solar field will be consistent with the amount and type of use they will receive.

FIGURE 1-11 PRELIMINARY ACCESS ROADS WITHIN PROJECT BOUNDRY

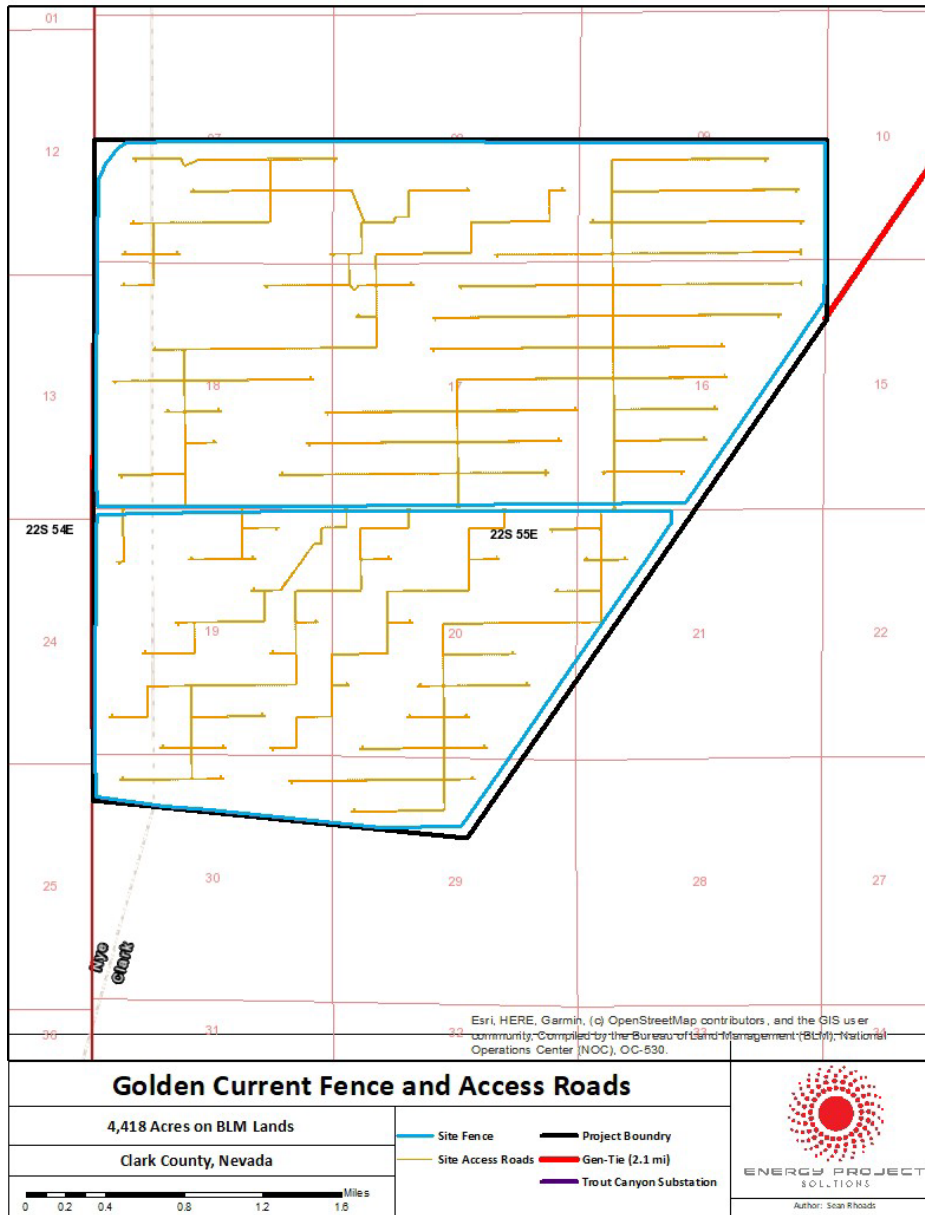

Concrete cutoff walls may also be installed at the edges of the road crossing within the drainages. The cutoff walls are installed in the edge of the road and do not require vegetation removal beyond what is already needed to construct the access road. The purpose of the cutoff walls is to prevent the access road materials from eroding during storm events. Without the cutoff walls, material can erode down the washes and additional heavy equipment will be needed to regrade the washes after major storms. The cutoff walls reduce the need for continued maintenance of the road using heavy equipment. Cutoff walls can be installed by hand or using small equipment, accessed from the internal road only, and the resultant concrete is flush with the ground surface.

Perimeter Road

A new perimeter road would be located just inside the site's perimeter fence and within the solar field area around specific blocks of equipment. The perimeter road would be constructed to allow access by maintenance and security personnel. The perimeter road would be approximately 20 feet wide and would be composed of native graded and compacted dirt. Alternatively, the perimeter road may use an aggregate base in some or all areas to meet Project dust and flood control requirements.

Solar Field Access Ways

Within the solar field, new access ways would be built to provide vehicle access to the solar equipment (PV modules, inverters, transformers) for O&M activities. These access ways would be approximately 20 feet wide and approximately every 500 to 1,300 feet across the solar field. The existing surface area would be graded and compacted using onsite materials to facilitate use by two-wheel-drive vehicles.

1.3.6 Linear Facilities

1.3.6.1 230 kV Gen-Tie Transmission Line

The Project would require the construction of an approximately 2.1 mile 230 kV monopole overhead circuit and telecommunications system (fiber optic system data) for interconnection to the utility transmission grid. The exact routing is still to be determined. Typical transmission structures are shown in **Figure 1-12**. A 20-foot-wide gen-tie road would run the length of the gen-tie line. The overhead line and telecommunications system (fiber optic system data) would be installed per local and national electrical code requirements. Structures would be galvanized steel with a dull gray appearance similar to existing steel poles installed adjacent to the site and would be used to support interconnection to the transmission system.

All overhead electrical lines would be designed and installed in accordance with the Avian Power Line Interaction Committee's (APLIC) Suggested Practices for Avian Protection on Power Lines (APLIC 2006). The Applicant also would prepare a Bird and Bat Conservation Strategy to address potential impacts to birds and bats during the construction, operations, and maintenance phases of the Project.

FIGURE 1-12 TYPICAL 230KV DOUBLE CIRCUIT MONOPOLE FOR GEN-TIE SUPPORT STRUCTURES

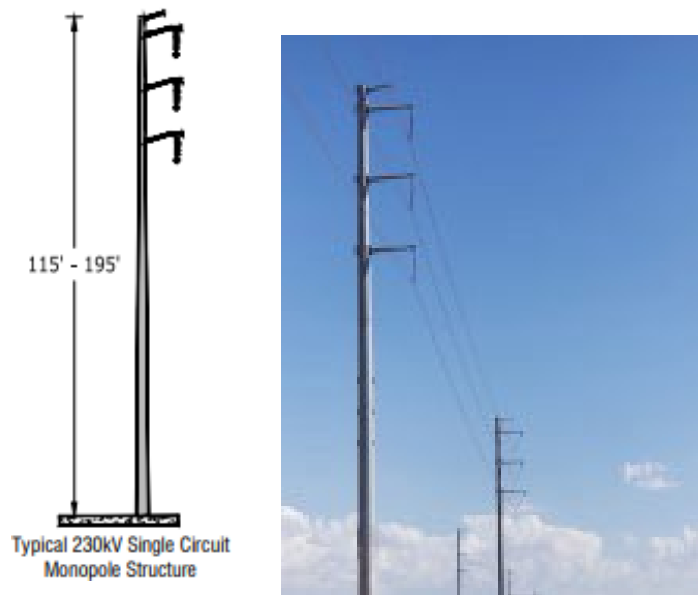

1.3.6.2 Access Roads

The access road for the Project during both construction and operation will be Tecopa Road, a paved, public roadway located adjacent to the eastern edge of the project site. Tecopa Road provides direct access to State Route 160 to the northeast. No additional access roads outside of the project boundary will be required.

1.3.7 Interconnection Facilities

Improvements to interconnection facilities are to be determined following detailed utility review of the project.

1.3.8 Water and Wastewater

All Project-related water use and facilities are described below.

1.3.8.1 Water

An estimated 1,000 acre-feet (AF) of water would be required over the Project construction period for construction-related activities, including dust control. After construction is complete, the Project's water consumption during operation would require up to 28 acre-feet per year. Water would not be used for panel washing but would be used in conjunction with dust palliatives during operation see Section 4.1, *Operation and Maintenance*. The Project would not require process water. Water is anticipated to be purchased from a commercial source or a user with an existing appropriation. It would then be trucked or piped to the Project site where it would be stored in an on-site water storage tank.

The BLM has allowed the use of several dust palliatives on other projects. If dust palliatives are used in place of water for the Project, the total amount of water needed during construction would be reduced. The Applicant may opt to use such palliatives, as authorized by the BLM for the Project. The soil binder/dust palliatives that are proposed for the Project, and which BLM previously has allowed are:

- Road Bond 1000
- For roads and heavy traffic areas: Soil Cement
- For non-traffic areas on finer soils: Formulated Soil Binder FSB 1000
- For non-traffic areas on sandier/rockier soils: Plas-TEX
- Alternatives as approved by BLM

1.3.8.2 Wastewater

Wastewater generated during construction would include sanitary waste from portable toilets. This waste would be collected by a contracted sanitary disposal service and transported to a licensed disposal facility. Since the facility will be manned by a small number of full time employees, no permanent wastewater facilities would be installed and the same portable toilets in use during construction would be utilized for ongoing operations.

1.3.9 Lighting

Permanent lighting would be provided within the substation and at the project entry gate. Small domestic fixtures would also be placed at other electrical equipment as required by applicable codes. Lighting for facilities and associated infrastructure would be down-shielded to keep light within the boundaries of the Project site and the minimum amount and intensity necessary for the intended use. Nighttime construction activities, if required, would be performed with temporary lighting. Night lighting used during construction, operation, and maintenance of the Project would be controlled or reduced using directed lighting, shielding, and/or reduced lumen intensity. The Applicant would prepare a Lighting Management Plan for construction and operation of the Project.

1.3.10 Waste and Hazardous Materials Management

The primary wastes generated at the Project during construction, operation, and maintenance would be nonhazardous solid and liquid wastes. The types of wastes and their estimated quantities are discussed below and summarized in **Table 1-4**. The Applicant would prepare a Hazardous Materials and Waste Management Plan, as well as an Spill Prevention and Emergency Response Plan, which would address waste and hazardous materials management, including Best Management Practices (BMPs) related to storage, spill response, transportation, and handling of materials and wastes.

TABLE 1-4 WASTES POTENTIALLY GENERATED BY THE PROJECT

Waste	Origin	Composition	Estimated Quantity	Classification	Disposal
Scrap wood, steel, glass, plastic, paper	Construction activities	Normal refuse	200 tons	Nonhazardous	Recycle and/or dispose of in industrial or municipal landfill
Scrap metals	Construction activities	Parts, containers	<2 tons	Nonhazardous	Recycle and/or dispose of in industrial or municipal landfill
Empty hazardous materials containers	Operation and maintenance of plant	Drums, containers, totes*	<1 tons	Hazardous and nonhazardous solids	Containers <5 gal would be disposed as normal refuse. Containers >5 gal would be returned to vendors for recycling or reconditioning.
Waste oil filters	Construction equipment and vehicles	Solids	500 lbs	Used Oil	Recycle at a permitted Treatment, Storage, and Disposal Facility (TSDF)
Oily rags, oil sorbent excluding lube oil flushes	Cleanup of small spills	Hydrocarbons	100 cubic ft	Used Oil	Recycle or dispose at a permitted TSDF
Spent lead acid batteries	Construction machinery	Heavy metals	10	Hazardous	Store no more than 10 batteries (up to 1 year)–recycle off site.
Spent alkaline batteries	Equipment	Metals	50 lbs	Universal waste solids	Recycle or dispose offsite at a Universal Waste Destination Facility
Waste oil	Equipment, vehicles	Hydrocarbons	500 gallons	Used Oil	Dispose at a permitted TSDF
Sanitary waste	Portable toilet holding tanks	Solids and liquids	200,000 gallons	Nonhazardous liquid	Remove by contracted sanitary service

* Containers include <5-gallon containers and 55-gallon drums or totes

1.3.10.1 Nonhazardous Wastes

The Project would produce wastes typically associated with O&M activities. These would include defective or broken electrical materials, empty containers, the typical refuse generated by workers and small office operations, and other miscellaneous solid wastes.

1.3.10.2 Hazardous Materials and Hazardous Waste

Limited quantities of hazardous materials would be used and stored on site for O&M activities. **Table 1-5** lists the hazardous materials anticipated that would be stored and used on site. Material Safety Data Sheets (MSDSs) for each of these materials would be provided in the Spill Prevention and Emergency Response Plan.

1.3.11 Fire Protection

The Project’s fire protection water system would be supplied from a water storage tank. During construction, one electric and one diesel-fueled backup firewater pump would deliver water to the fire protection water-piping network. The electrical equipment enclosures that house the inverters and transformers would be either metal or concrete structures. Any fire that could occur would be

contained within the structures, which would be designed to meet National Electric Manufacturers Association (NEMA) 1 or NEMA 3R IP44 standards for electrical enclosures (heavy duty sealed design to withstand harsh outdoor environmental conditions). The Applicant would prepare and implement a Fire Management Plan.

TABLE 1-5 HAZARDOUS MATERIALS THAT MAY BE USED DURING OPERATION

Hazardous Material	Storage Description; Capacity	Storage Practices and Special Handling Precautions
Mineral Insulating Oil	Carbon steel transformers; total onsite inventory of 40,000 gallons.	Used only in transformers, secondary containment for each transformer would be managed in accordance with the Spill Response and Emergency Response Plan.
Batteries, lead acid based and/or lithium ion	Battery-based emergency back-up power at each of the PCS.	Sufficient cooling capacity to maintain ambient temperatures appropriate for the selected battery would be provided.
Propane	Generator-based emergency back-up power at each of the five PCS shelters (or one centralized generator); tanks at PCS will be sized between 20 and 100 gallons (or 500 gallons if one centralized tank).	Would be managed in accordance with the Spill Response and Emergency Response Plan.
Herbicide Roundup (glyphosate) or equivalent; Pesticide	Brought on site by licensed contractor, used immediately.	No mixing will occur onsite and no herbicides will be stored onsite.

1.3.12 Health and Safety Program

The Applicant would require that all employees and contractors adhere to appropriate health and safety plans and emergency response plans. All construction and operations contractors would be required to operate under a Health and Safety Program (HASP) that meets industry standards. All site personnel would be required to go through a new hire orientation and follow a Worker Education and Awareness Plan (WEAP), which would address Project-specific safety, health, and environmental concerns.

1.3.13 Stormwater Management

Major existing FEMA-designated floodplains on the Project site would be avoided where feasible, with the exception of roadway crossings, and the Project would be designed and engineered to maintain the existing hydrology. Generally, offsite flows to the Project site come from the northwest. Runoff generated onsite would be conveyed as sheet flow across the site, maintaining as much of the natural grade of the terrain as possible. The soil is very permeable so following the natural terrain would allow for maximum infiltration thereby reducing runoff. Drainage channels or detention basins may be installed per the results of a hydrology study as shown on **Figure 1-13**.

FIGURE 1-13 TYPICAL SECTIONS OF DRAINAGE FEATURES

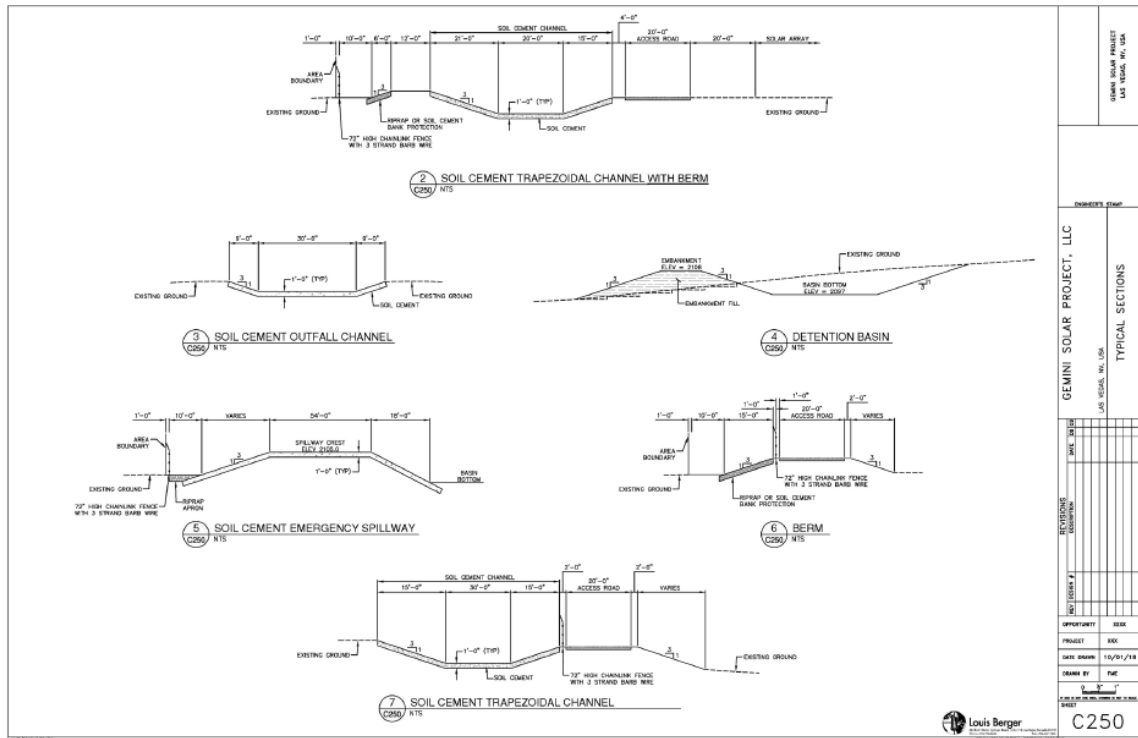

1.3.14 Vegetation Management

The site would be allowed to re-vegetate following construction. Vegetation would typically be maintained to a height of no more than approximately 12 inches as needed for site maintenance and fire-risk management using mechanical and chemical controls as shown in **Figure 1-14**. Project roads and the O&M area would remain free of vegetation. The Applicant will address post construction vegetation management including invasive and noxious weed control as part of a BLM approved Integrated Weed Management Plan for the Project.

FIGURE 1-14 REPRESENTATIVE VEGETATION HEIGHTS DURING CONSTRUCTION AND MAINTENANCE



1.3.14.1 Noxious Weed and Pest Control

The Applicant would prepare an Integrated Weed Management Plan for the Project that would follow the Resource Management Plan, Noxious Weed Plan, and the interagency guidance Partners Against Weeds (BLM 2007c) for an active integrated weed management program. BLM-approved herbicides such as Roundup (glyphosate) would be used to control noxious weeds, if required. Pest control may also be required, including control of rodents and insects inside of the buildings and electrical equipment enclosures.

1.4 Alternatives

Alternative technologies and project layouts will be defined by BLM staff in accordance with the NEPA process. Alternatives considered and carried forward for full environmental comparison in the BLM's NEPA process may also include:

1. **No Action Alternative A:** The ROW application would be denied.
2. **Alternative Technology Alternative B:** The ROW application would be approved with the use of an alternative, concentrating solar technology.

The lead agency staff (NV BLM) will determine which alternatives to carry forward for full analysis in the NEPA process.

1.5 Other Potential Permits and Authorizations

Table 1-6 provides a list of federal, state, and local permits, authorizations, or inter-agency consultations that may be required for the Project.

TABLE 1-6 FEDERAL, STATE, AND LOCAL PERMITS AND AUTHORIZATIONS

I. Federal Permits, Authorizations or Inter-Agency Consultations							
<i>U.S. Department of the Interior, BLM</i>							
<ul style="list-style-type: none"> • ROW grant under Title V of the Federal Land Policy and Management Act • Environmental Impact Statement (EIS) and Decision Record to support issuance of ROW grant 							
<i>U.S. Department of the Interior, BLM and State Historic Preservation Office/Advisory Council on Historic Preservation</i>							
<ul style="list-style-type: none"> • BLM/State Historic Preservation Office, National Historic Preservation Act Section 106 Consultation 							
<i>U.S. Department of the Interior, Fish and Wildlife Service</i>							
<ul style="list-style-type: none"> • Endangered Species Act Section 7 Consultation and Biological Opinion/Incidental Take Statement 							
<i>Federal Aviation Administration (FAA)</i>							
<ul style="list-style-type: none"> • Obstruction Evaluation with FAA in coordination with the US Air Force 							
<i>U.S Army Corps of Engineers</i>							
<ul style="list-style-type: none"> • Section 404 Permit for impacts to jurisdictional waters 							
II. State of Nevada Permits or Authorizations							
<i>Nevada State Historic Preservation Office</i>							
<ul style="list-style-type: none"> • BLM/State Historic Preservation Office, National Historic Preservation Act Section 106 Consultation 							
<i>Nevada Department of Wildlife</i>							
<ul style="list-style-type: none"> • Fund for the Recovery of Costs • Special Purpose Permit (for subcontractor) 							
<i>Nevada Division of Environmental Protection</i>							
<ul style="list-style-type: none"> • General Stormwater Permit for Construction Activities (Notice of Intent and General Permit) • Section 401 of the Clean Water Act Water Quality Certification • Working in Waters Permit 							
<i>Nevada Division of Forestry</i>							
<ul style="list-style-type: none"> • Native Cacti and Yucca Commercial Salvaging and Transportation Permit • State List Endangered Species Take Permit 							
<i>Nevada Public Utilities Commission</i>							
<ul style="list-style-type: none"> • Nevada Utility Environmental Protection Act Permit 							
<i>Nevada Division of Water Resources</i>							
<ul style="list-style-type: none"> • Groundwater Well Permit 							
<i>Nevada Department of Motor Vehicles and Public Safety</i>							
<ul style="list-style-type: none"> • Nevada State Hazardous Materials Storage Permit 							
<i>Nevada Department of Transportation</i>							
<ul style="list-style-type: none"> • Right-of Way Occupancy or Encroachment Permit for facilities, such as transmission lines crossing state highways 							
III. Clark County Permits							
<i>Clark County Department of Air Quality</i>							
<ul style="list-style-type: none"> • Dust Control Permit 							
<i>Clark County Regional Flood Control District</i>							
<ul style="list-style-type: none"> • Drainage Study Approval 							
<i>Clark County Department of Comprehensive Planning</i>							
<ul style="list-style-type: none"> • Special Use Permit 							
<i>Clark County Building Department</i>							
<ul style="list-style-type: none"> • Grading Permit • Building Permit 							

NOTES: FLPMA = Federal Land Policy and Management Act
 NHPA = National Historic Preservation Act
 SHPO = State Historic Preservation Office

1.6 Financial and Technical Capability of the Applicant

1.6.2 Primergy Solar

Primergy Solar LLC, the development manager for Noble Solar, LLC, develops, owns, and operates distributed and utility-scale PV solar and battery storage projects in North America. Primergy Solar is a privately-held company with operations in the United States. The company manages a multi-gigawatt portfolio of solar development projects across the United States. Members of Primergy Solar's management team have successfully developed over 2 GW of utility-scale PV solar energy plants to commercial operations.

Primergy Solar is wholly owned by Quinbrook Infrastructure Partners, a specialist investment manager focused exclusively on low carbon infrastructure investment. Quinbrook operates in the US, UK, and Australia, and has invested more than \$28 billion in 19 GW of energy infrastructure assets, with a focus on utility-scale wind, solar, and battery storage. Quinbrook successfully raised \$1.7 billion in 2019 for its Low Carbon Power Fund, which is earmarked for investment in three US ventures including Primergy Solar.

SECTION 2

Construction of the Facilities

2.1 Overview

Construction is expected to take up to 12 months and would include the major phases of mobilization, construction grading and site preparation, installation of drainage and erosion controls, PV panel/tracker assembly, and solar field construction. The Applicant is planning to commence construction in the fourth quarter of 2022. Some aspects of construction will need to be coordinated with the ultimate Interconnection Provider and local utilities.

2.2 Temporary Construction Workspace, Laydown and Mobilization Areas

No temporary work areas will be required outside of the project boundary. The Project construction contractor would develop a temporary construction mobilization and laydown area within the northwestern portion of the Project site that would include temporary construction trailers with administrative offices, construction worker parking, temporary water service and fire water supply holding tanks, temporary construction power services, tool sheds and containers, as well as a laydown area for construction equipment and material delivery and storage.

In addition, temporary construction areas would be located at each tower location and at locations required for conductor stringing and pulling operations along the 150-foot-wide ROW, required to accommodate construction and operation of the gen-tie from the project boundary to Trout Canyon Substation located 2.1 miles Northeast along Tecopa Road. These areas would be required for staging equipment and materials for foundation construction and tower installation.

Temporary power is expected to be provided by Valley Electric Association (VEA) by way of their existing 24.9kv distribution system in the area.

Water needed to support construction and permanent operations will be supplied to the site by either offsite water hauling or from private adjacent lands.

Temporary and permanent sewer will be handled through the use of portable toilets and holding tanks, typically referred to as port-o-potties. The waste would be collected by a contracted sanitary disposal service and transported to a licensed disposal facility. Since the facility will be manned by a small number of full-time employees, no permanent wastewater facilities would be installed and the same portable toilets in use during construction would be utilized for ongoing operations.

2.3 Site Preparation

A geotechnical investigation and environmental clearance surveys would be performed at the Project site prior to commencement of construction activities. During the environmental clearance phase, the boundaries of the construction area would be delineated and marked. The site then would be prepared for use; existing vegetation removal and grading would be minimized to the extent reasonably practicable. Site preparation techniques are described below.

2.3.1 Land Surveying and Staking

Prior to construction, the limits of construction disturbance areas would be determined by surveying and staking. Where necessary, the limits of the ROW also would be flagged. All construction activities would be confined to these areas to prevent unnecessary impacts affecting sensitive areas. These areas, which would include buffers established to protect biological resources, also would be staked and flagged. The locations of underground utilities would be located and staked and flagged in order to guide construction activities.

2.3.2 Vegetation Removal and Treatment

Within the solar field areas that would be graded, existing vegetation would be worked into the underlying surface soils. Vegetation would be permanently cleared from roadways, access ways, and where concrete foundations are used for the inverter equipment, substations, and O&M facilities. A 10-foot-wide fire break would be established around the outside of the perimeter fence and maintained clear of vegetation. Vegetation Management is discussed in Section 1.3.14, *Vegetation Management*.

2.3.3 Site Clearing, Grading, and Excavation

All earthwork required to install drainage control detention basins, access roads, and foundations for Project-related buildings would be balanced on site. Trenching would be required for placement of collector lines. The solar field would require a positive natural terrain slope of less than 5 percent. The disk and roll technique would be used generally to prepare the surface of the solar field for post and PV panel installation. The disk and roll technique uses conventional farming equipment to prepare the site for construction. Typical farming equipment includes: rubber tired tractors with disking equipment and drum rollers with limited use of scrapers to perform micrograding. In areas where the terrain is not suitable for disk and roll, conventional cut and fill grading would be used.

Solar Field and Internal Roads. Within the solar field, some grading would be required for roads and access ways between the solar arrays, and for electrical equipment pads. In general, the design standard for the roads and access ways within the solar field would be consistent with the amount and type of use they would receive.

Substation. The substation would require a graded site to create a relatively flat surface for proper operation, with approximately 1 percent maximum slope in either direction. The substation interior would be covered with aggregate surfacing for safe operation.

2.3.4 Gravel, Aggregate, and Concrete Needs and Sources

Concrete would be poured in place for equipment and building foundations, fence footing and miscellaneous small pads. Aggregate material would be used for the trench backfill, parking lot and substation area (and if determined necessary, for the perimeter road and access roads). Riprap material may be required for erosion control. The Applicant would determine a source for these materials that would be presented for BLM review and approval, as necessary.

2.4 PV Solar Array Assembly and Construction

Prior to any construction in PV equipment areas, the clearance and site preparation steps for those areas would be completed. Within each area designated for PV equipment, the construction sequence would follow a generally consecutive order.

1. The construction of the solar field would proceed by arrays. Each array would contain solar panels, a PCS, and a step-up transformer. Within each array, materials for each row of PV modules would be staged next to that row. Prepare trenches for underground cable;
2. Install underground cable;
3. Backfill trenches;
4. Install steel posts and table frames;
5. Install PV modules;
6. Install concrete footings for inverters, transformers, and substation equipment;
7. Install inverter and transformer equipment;
8. Perform electrical terminations; and
9. Inspect, test, and commission equipment.

Cable trenches would be used to provide underground connection of Project equipment. Trenches would contain electrical conductors for power generation and fiber optic cables for equipment communication. Trenches would vary between 2 to 3 feet wide and 2 to 3 feet deep depending on the number of conductors and voltage of equipment to comply with applicable electrical codes.

The assembled solar equipment would be installed on steel posts to which steel table frames would be attached. Trucks would be used to transport the PV modules to the solar field. A small mobile crane may be used to assist construction workers in setting the solar modules on the driven steel posts. Final solar field assembly would require small cranes, tractors, and forklifts.

2.5 Electrical Collection and Transmission System Construction

Electrical construction would consist primarily of the following elements:

1. **Equipment**—Installation of all electrical equipment including DC combiner boxes, PCS Shelters (including inverters), transformers, circuit breakers, disconnect switches, switchgear and distribution panels, lighting, communication, control, and SCADA equipment.
2. **Cables**—Installation of all cables necessary to energize the Project equipment including instrument control wiring. High, medium, and low voltage cables would be routed via cable trays, above-grade conduits, below-grade conduit in duct bank, and overhead structures.
3. **Grounding**—All equipment and structures would be grounded as necessary. Within the solar field, an appropriate grounding system would be engineered and constructed in order to maintain personnel safety and equipment protection.
4. **Telecommunications**—Multiple communication systems would be required for the Project to properly operate, including T-1 internet cables, fiber optic, microwave, and telephone. All communications would be installed during electrical construction.

2.5.1 Standard Transmission Line Construction Techniques

The Project would include an overhead 34.5 kV collection system and overhead 230 kV gen-ties. Standard transmission line construction techniques would be used to construct the collector and gen-tie lines. Primary stages in transmission line construction are foundation installation, tower installation, and conductor stringing. Up to a 100-foot by 700-foot temporary laydown or staging area would be required at each 230 kV tower location for equipment, towers, and hardware. In general, little to no grading is expected to be required for these areas. Typical equipment expected to be used for transmission line construction includes: backhoe, truck-mounted tower hole auger, forklift, crane, line truck with air compressor, various pickup and flatbed trucks, conductor reel and tower trailers, bucket trucks, and truck-mounted tensioner and puller.

Foundation Installation. The steel towers used for the gen-tie would be supported by steel-reinforced poured pier concrete foundations suitable for the sandy soil conditions at the site. These foundations are constructed by auguring a cylindrical hole using a truck-mounted drilling rig. Reinforcing steel and anchor bolt cages would be installed in the hole and then the hole would be backfilled with concrete. Steel tower foundations would range in size from approximately 4 to 7 feet in diameter, and in depth from 12 to 30 feet. Wood monopoles used for the overhead 34.5 kV collector line would be embedded into the ground to a depth of at least 10 percent of the pole height plus 2 feet. Installation of wood poles is anticipated to require auguring holes approximately 2 feet in diameter and 8 feet deep. Aggregate or high-strength backfill would be used to stabilize the installed poles. Angle points on the 34.5 kV collection line would require steel monopoles supported by steel-reinforced poured pier concrete foundations.

Tower/Pole Installation. Monopoles would be placed onto their foundations (for wood, placed into their holes) using backhoes or heavy lifter vehicles for the smaller, lighter poles, or a crane for longer poles. The poles would be supported, as necessary, during backfilling or bolting to the foundation to ensure correct pole seating.

Conductor Stringing. Conductor stringing would likely be conducted one phase at a time, with all equipment in the same operational place until all phases of that operation are strung.

Grounding. Ground rods would be hammered into the earth with a jackhammer device attached to a small excavator (such as a Bobcat). Typically, the rods are 8 to 12 feet long and can be longer if needed by joining multiple rods. For the 34.5 kV wood monopoles, a 3-foot square by 2-foot-deep area would be excavated to expose the ground rod for connection to the plant's grounding grid.

2.6 Road System Construction

Preconstruction activities for the Project-related roads would include meeting any necessary plant salvage requirements. The construction entrance and exit gates would be established. The Project's main access point would be graded and constructed in order to facilitate entry to the Project site. Within the solar field, some grading would be required for roads and access ways between the solar arrays. As part of the gen-tie line, a permanent 20-foot-wide gen-tie road would be constructed that would run the length of the gen-tie line. All Project-related roads are proposed to be native graded/compacted dirt; however, roads may alternatively use an aggregate base in some or all areas to meet Project dust and flood control requirements.

Any temporary or permanent crossings under existing transmission lines will be coordinated and approved with NV Energy or line owner. In addition, the use of all existing permitted roads will be coordinated with NV Energy or other line owner.

Roadways with the designated FEMA floodplains would be constructed per the guidelines outlined in Chapter 9 of *Low Volume Roads Engineering, Best Management Practices Field Guide* (2003), as approved by the BLM.

2.7 Substation Construction

The shared substation would be constructed in compliance with applicable electrical safety codes. Substation construction would consist of site grading, concrete equipment foundation forming and pouring, crane-placed electrical and structural equipment, underground and overhead cabling and cable termination, ground grid trenching and termination, control building erection, and installation of all associated systems including, but not limited to heating, ventilating, and air conditioning (HVAC) system components; distribution panels; lighting; communication and control equipment; and lightning protection.

The substation area would be excavated to a depth of 10 feet. A copper grounding grid designed to meet the requirements of IEEE 80, "IEEE Guide for Safety in AC Substation Grounding," would be installed and the foundations for transformers and metal structures would be prepared.

After installation of the grounding grid, the area would be backfilled, compacted and leveled followed by the application of 6 inches of aggregate rock base. Equipment installation of the transformers, breakers, buswork and metal dead-end structures would follow. A pre-fabricated control house would be installed to house the electronic components required of the substation equipment. Containment measures for all substation equipment shall be provided in accordance with Environmental Protection Agency 40 CFR Part 112 and all applicable codes required by the local, state, and federal governing authorities. The transformer containment area would be lined with an impermeable membrane covered with gravel, and would include a drain with a normally closed drain valve. Transformers shall be provided with secondary oil containment equal to 110% of the volume of oil present in the transformer in addition to the volume of rain water for a 25-year, 24-hour rainfall event.

2.8 Site Stabilization, Protection, and Reclamation

Appropriate water erosion and dust-control measures would be implemented to prevent an increased dust and sediment load to ephemeral washes around the construction site and to comply with Clark County dust control requirements. Dust during construction would be controlled and minimized by applying water and/or BLM-approved palliatives discussed in draft 1.3.8, *Water*.

The Applicant would employ BMPs to protect the soil surface by covering or binding soil particles. The Project would incorporate erosion-control measures required by regulatory agency permits and contract documents as well as other measures selected by the contractor. Project-specific BMPs would be designed by the contractor and included in the Project SWPPP.

The Applicant would prepare a Site Rehabilitation and Restoration Plan. This plan would be implemented immediately after construction for the areas that are temporarily disturbed, such as portions of the transmission line route that involve disturbance.

2.9 Workforce, Schedule, Equipment, and Materials

The onsite construction workforce would consist of laborers, craftsmen, supervisory personnel, support personnel, and construction management personnel. The onsite construction workforce is anticipated to be an average of 350 to 700 construction workers with a peak of up to 900 to 1000 workers at any given time. Most construction staff and workers would commute daily to the jobsite, primarily from the Las Vegas metro area and Pahrump.

Construction generally would occur between 5:00 a.m. and 5:00 p.m., and may occur seven days a week. Additional hours may be necessary to make up schedule deficiencies, or to complete critical construction activities. For instance, during hot weather, it may be necessary to start work earlier (e.g., at 3:00 am) to avoid work during high ambient temperatures. Further, construction requirements would require some night-time activity for installation, service or electrical connection, inspection and testing activities.

Construction activities would follow a generally consecutive order, however, most construction activities associated with each construction component would overlap to some degree and would include the following:

1. Installation of fencing;
2. Construction of the access road, laydown areas, substation concrete pad and distribution line;
3. Site preparation activities, and construction of drainage control detention basins;
4. Erection of collection system and substation; and
5. PV solar array assembly, construction and commissioning.

Table 2-1A, 2-1B, and 2-1C, below, provides a description of the onsite equipment expected to be used for solar panel array and collection system construction (Table 2-1A), substation construction (Table 2-1B), and gen-tie line construction (Table 2-1C). Actual construction equipment details and durations may vary.

TABLE 2-1A ESTIMATED ON-SITE EQUIPMENT FOR SOLAR PANEL ARRAY AND COLLECTION SYSTEM CONSTRUCTION

Equipment Description	Daily Quantity	Horse-power	Fuel Type	Equivalent Full-Load Operating Time (hr/day)	Vehicle Miles (VMT) per Day on Unpaved Surface
Install BMP Measures (Part of Site Preparation)					
Rough Terrain Forklift	2	75	Diesel	1.7	10
Delivery / Work Trucks	3	200	Diesel	2	5
Site Prep – Solar Arrays					
Truck, Pick-Up (Survey Crew)	2	180	Gas	1.7	5
Grader	6	200	Diesel	6.8	20
Backhoe/Front Loader	2	120	Diesel	3.4	20
Tractor / Disc	3	210	Diesel	6.8	40
Scraper	4	265	Diesel	3.4	30
Compactor	2	120	Diesel	1.7	10
Water Truck	2	175	Diesel	6.8	N/A
Site Prep – Roads					
Grader	3	200	Diesel	6.8	20
Backhoe/Front Loader	1	120	Diesel	6.8	10
Compactor	2	120	Diesel	6.8	20
Water Truck	2	175	Diesel	6.8	N/A
Dump Truck	5	235	Diesel	2.7	10
Install Fencing					
Rough Terrain Forklift	2	75	Diesel	1.7	10
Delivery / Work Trucks	3	200	Diesel	1	5
Post Installation					
Delivery / Work Trucks	2	200	Diesel	1	5
Post Machine	7	45	Diesel	8.1	1
Rough Terrain Forklift	2	75	Diesel	6.8	10
Install Support Structure					
Rough Terrain Forklift	6	75	Diesel	6.8	10

TABLE 2-1A ESTIMATED ON-SITE EQUIPMENT FOR SOLAR PANEL ARRAY AND COLLECTION SYSTEM CONSTRUCTION

Equipment Description	Daily Quantity	Horse-power	Fuel Type	Equivalent Full-Load Operating Time (hr/day)	Vehicle Miles (VMT) per Day on Unpaved Surface
Delivery / Work Trucks	2	200	Diesel	1	5

Install Inverters and Switchgear & sub-structure

Crane	2	125	Diesel	4.5	1
Backhoe/Front End Loader	2	120	Diesel	6.8	10
Delivery / Work Trucks	2	200	Diesel	1	5

DC and AC Wire Installation (UG)

Backhoe/Front Loader	4	120	Diesel	6.8	10
Crawling Trencher	2	100	Diesel	4.1	1
Mini-Excavator	4	42	Diesel	6.8	10
Delivery / Work Trucks	2	200	Diesel	1	5

DC and AC Wire Installation (AG)

Rough Terrain Forklift	3	75	Diesel	1.7	10
Delivery / Work Trucks	2	200	Diesel	1	5

Module Installation

Rough Terrain Forklift	15	75	Diesel	1.7	10
Delivery / Work Trucks	5	200	Diesel	1	5

O&M Building

Rough Terrain Forklift	1	75	Diesel	1	1
Manlift	2	110	Diesel	3	1

Misc. (Across Project Site)

Crane, Hydraulic, Rough Terrain	1	125	Diesel	1.5	N/A
Delivery: Truck, Semi, Tractor	1	310	Diesel	0.5	5
Delivery: Truck, Flatbed, 1 Ton	1	180	Diesel	0.5	5
Forklift, less than 5 Ton	3	75	Diesel	3.8	5
Forklift, greater than 5 Ton	2	85	Diesel	3.8	5
Motor, Auxiliary Generator Power for trailers	4	24	Diesel	8	N/A
Trailer, Office, 40'	14	N/A	N/A	N/A	N/A
Trailer, Office, 20'	4	N/A	N/A	N/A	N/A
Skid Steers	5	75	Diesel	1.7	5
AWD Gator/Cart	20	15	Diesel	8.1	10
Water Truck	4	175	Diesel	6.8	N/A
Delivery / Work Trucks	10	200	Diesel	1	5
Electrical Generators/Pumps	4	50	Diesel	8.1	N/A

TABLE 2-1B ESTIMATED ON-SITE EQUIPMENT FOR SUBSTATION CONSTRUCTION

Equipment Description	Daily Quantity	Horse-power	Fuel Type	Equivalent Full-Load Operating Time (hr/day)	Vehicle Miles (VMT) per Day on Unpaved Surface
Steel Structures					
Boom Truck - 33 Ton	2	290	Diesel	1.5	1
Manlift	2	110	Diesel	1.2	1
Material Delivery - Hwy Tractor w 40' Flat	6	220	Diesel	0.2	4
Insulators, Bus, & Electrical Equipment					
Boom Truck	2	220	Diesel	1.5	1
Manlift	4	110	Diesel	1.2	1
Welder Truck	4	210	Diesel	1.2	4
Material Delivery - Hwy Tractor w 40' Flat	8	310	Diesel	0.2	4
Material Delivery - Heavy Haul	2	300	Diesel	1.5	4
Crane	2	500	Diesel	1	N/A
Control Wiring					
Boom Truck	2	220	Diesel	0.6	1
Manlift	4	110	Diesel	0.8	1
1 ton crew vehicle	2	260	Diesel	0.2	4
Fiber Splicer Van	2	180	Gas	0.6	4
Test Equipment Van	2	180	Gas	1.7	4
Rough Terrain Forklift	2	75	Diesel	1.7	6

TABLE 2-1C ESTIMATED ON-SITE EQUIPMENT FOR GEN-TIE LINE CONSTRUCTION

Equipment Description	Daily Quantity	Horse-power	Fuel Type	Equivalent Full-Load Operating Time (hr/day)	Vehicle Miles (VMT) per Day on Unpaved Surface
Steel (Hauling, Shake-Out, Assembly and Erection)					
Crane, Hydraulic, 150/300 Ton	2	250	Diesel	1.8	5
Crane, Hydraulic, Rough Terrain, 25 Ton	2	125	Diesel	1.8	5
Truck, Flatbed w/Boom, 12 Ton	2	235	Diesel	1	10
Truck, Crew Cab, Flatbed, 1 Ton	12	180	Gas	1.1	10
Truck, Semi Tractor	2	310	Diesel	6	10
Trailer, Flatbed, 40'	2	N/A	N/A		10
Water Truck	2	175	Diesel	4.5	N/A
Motor, Auxiliary Power	2	5	Gas	1	0
Compressor, Air	2	75	Gas	2	15
Conductor / Shield Wire / OPGW (Stringing, Sagging, Deadending and Clipping)					
Truck, Flatbed, w/ Bucket	3	235	Diesel	3	15
Tension Machine, Conductor	2	135	Diesel	1.5	1
Tension Machine, Static	2	135	Diesel	0.2	1
Truck, Sock Line, Puller, 3 Drum	2	310	Diesel	2.3	1
Truck, Wire Puller, 1 Drum	2	310	Diesel	2.3	1
Truck, Semi, Tractor	4	310	Diesel	6	10
Water Truck	2	175	Diesel	4.5	N/A
Truck, Crew Cab, Flatbed, 1 Ton	6	180	Gas	1.4	10
Back Hoe, w/ Bucket	2	85	Diesel	3	1
Truck, Mechanics	2	260	Diesel	3	15
Crane, Hydraulic, Rough Terrain	2	125	Diesel	1	10

Motor, Auxiliary Power	4	5	Gas	2.3	N/A
------------------------	---	---	-----	-----	-----

TABLE 2-1C ESTIMATED ON-SITE EQUIPMENT FOR GEN-TIE LINE CONSTRUCTION

Equipment Description	Daily Quantity	Horse-power	Fuel Type	Equivalent Full-Load Operating Time (hr/day)	Vehicle Miles (VMT) per Day on Unpaved Surface
Cleanup					
Truck, Flatbed, w/ Bucket, 5 Ton	2	235	Diesel	2	5
Excavator, Bucket Type	2	165	Diesel	4.5	5
Truck, Semi, Tractor	2	310	Diesel	4.5	10
Truck, Dump, 10 Ton	2	235	Diesel	3	10
Motor Grader	2	110	Diesel	8	20
Truck, Flatbed	2	210	Diesel	2.1	10
Truck, Pick-Up	2	210	Diesel	2.1	10
Motor, Auxiliary Power	2	5	Gas	0.5	N/A

2.10 Construction Traffic

Typical construction traffic would consist of trucks transporting construction equipment and materials to and from the site and vehicles of management and construction employees during the construction period. Most construction staff and workers would commute daily to the jobsite. All traffic would likely use State Route 160 and Tecopa Road to access the site. Prior to the start of construction, the Applicant would prepare a Traffic Management Plan to address Project-related traffic.

2.11 Construction Power

A new distribution line interconnecting to existing NV Energy distribution service would be installed to provide electricity to the substation to serve both the Project during construction and operations. Distribution line poles would be spaced between 55 feet high from ground surface and an average of 300 feet from one another. In addition, a temporary overhead line would be installed during construction to provide power to the laydown areas. Alternatively, generators may be used to provide temporary construction and operation power.

SECTION 3

Related Facilities and Systems

3.1 Transmission System Interconnect

3.1.1 Proposed Transmission System

The overhead 230 kV gen-tie line would be installed as described in Section 2.5.1 and would transmit power generated by the Project from the project substation to the existing Trout Canyon 230 kV substation.

3.1.2 Ancillary Facilities

To be determined.

3.1.3 Status of Power Purchase Agreements

The Applicant intends to sell power from the Project in accordance with a PPA to be negotiated with one or more utilities.

3.1.4 Status of Interconnection Agreement

The project holds an interconnection queue position at the Trout Canyon 230 kV substation.

3.1.5 General Design and Construction Standards

The Project would be designed in accordance with federal and industrial standards including American Society of Mechanical Engineers standards, National Electrical Safety Code, International Energy Conservation Code, International Building Code, Uniform Plumbing Code, Uniform Mechanical Code, and National Fire Protection Association and Occupational Safety and Health Administration standards.

Construction would be in accordance with the federal codes listed above and all applicable state and local codes.

3.2 Gas Supply Systems

The Project would not require a natural gas supply system.

3.3 Other Related Systems

3.3.1 Communication System Requirements

Multiple communication systems would be used for construction and operation. These items would include telephone, fiber optics, and T1 internet. The Applicant expects to utilize existing wired or wireless telecommunications facilities. In the event that these facilities are not available in the Project vicinity, the Applicant would install hard-wired (land-line) systems as part of the electrical construction activities or would supplement with small aperture (less than 1 meter) satellite communications gear.

SECTION 4

Operation and Maintenance

4.1 Operation and Maintenance

The facility will operate 7 days a week. It is expected operations staff would be located off-site, with site visits occurring daily for security, maintenance, and repairs. To maintain generation performance, PV array washing may occur up to 24 hours per day (including nighttime panel washing), with approximately two panel washes anticipated per year. A solar PV project uses no process water, gas, or fuels for the power generation process.

A plant operation and maintenance program, typical of a project this size, will be implemented to control the quality of operations and maintenance. The frequency and type of maintenance is described in **Table 4-1**. During the first year of operation, the frequency of inspections would be increased to address settling and electrical termination torque (e.g., for year 1, inspections shown as semi-annually are performed quarterly, inspections shown as annual are performed semi-annually). At designated intervals, approximately every 10 to 15 years, major equipment maintenance would be performed. Operations and maintenance procedures will be consistent with industry standards practices to maintain useful life of plant components.

Operation and maintenance would require the use of vehicles and equipment including crane trucks for minor equipment maintenance. Additional maintenance equipment would include forklifts, manlifts, and chemical application equipment for weed abatement and soil stabilizer treatment in the bioremediation area. Pick-up trucks would be in periodic on the site. No heavy equipment would be used during normal plant operation.

Golden Currant Solar is expected to have an annual equivalent plant availability of 92 to 98 percent. It will be possible for plant availability to exceed 98 percent for a given 12-month period.

The facility will be operated in one of the following modes:

1. The facility will be operated at its maximum continuous output for as many hours per year as sunlight is available.
2. Small portions of the facility may be temporarily shut down for repairs.
3. Only in the case of a transmission system disconnect would the facility encounter a full shutdown.

Dust during operations and maintenance would be controlled and minimized by applying water and/or BLM-approved palliatives (See Section 2.8, *Site Stabilization, Protection, and Reclamation*).

TABLE 4-1 ROUTINE MAINTENANCE PROTOCOL

Equipment	Maintenance Interval	Task
PV Modules	Quarterly	<ul style="list-style-type: none"> • Visually inspect panels for breakage and secure mounting • Visually inspect modules for discoloration • Visually inspect wiring for connections and secure mounting • Visually inspect mounting structure for rust and erosion around foundations • Manually clean localized debris from bird droppings, etc.
	Semi-Annually	<ul style="list-style-type: none"> • Clean modules if determined necessary
Inverters	Semi-annually	<ul style="list-style-type: none"> • Perform temperature checks on breakers and electrical terminations • Visual inspection of all major components and wiring harnesses for discoloration or damage • Measure all low voltage power supply levels • Inspect/remove any dust/debris inside cabinet • Inspect door seals • Check proper fan operation • Inspect and clean (replace if necessary) filters • Check electrical termination torque • Check the operation of all safety devices (e-stop, door switches, ground fault detection)
	Annually	<ul style="list-style-type: none"> • Check all nuts, bolts and connections for torque and heat discoloration • Calibrate control board and sensors • Inspect air conditioning units for proper operation
Medium voltage transformers	Semi-annually	<ul style="list-style-type: none"> • Perform temperature check • Inspect door seals • Record all gauge readings • Clean any dirt/debris from low voltage compartment
Substation transformers	Semi-annually	<ul style="list-style-type: none"> • Inspect access doors/seals • Inspect electronics enclosure and sensor wiring • Record all gauge readings
	Annually	<ul style="list-style-type: none"> • Inspect fans for proper operation • Calibrate temperature and pressure sensors • Pull oil sample for oil screening and dissolved gas analysis.
Breakers and switchgear	Semi-annually	<ul style="list-style-type: none"> • Inspect for discoloration of equipment and terminations • Inspect door seals

TABLE 4-1 ROUTINE MAINTENANCE PROTOCOL

Equipment	Maintenance Interval	Task
	Annually	<ul style="list-style-type: none"> • Check open/close operation
Overhead transmission lines	Annually (and after heavy rains)	<ul style="list-style-type: none"> • Inspect guy wires and tower angle • Visual inspection of supports/insulators • Visual inspection for discoloration at terminations
Roadways	Annually (and after heavy rain)	<ul style="list-style-type: none"> • Inspect access ways and roads that cross drainage paths for erosion
Vegetation	Semi-annually	<ul style="list-style-type: none"> • Noxious weed inspections would be conducted in accordance with the BLM- approved Integrated Weed Management • Inspect for localized vegetation control to restrict height to less than 12 inches to address faster growth vegetation • Apply herbicides as necessary to control noxious weeds
	Every 3 years	<ul style="list-style-type: none"> • Mowing as required to reduce vegetation height to 9 inches
Water Wells	Annually	<ul style="list-style-type: none"> • Visual inspection • Pressure test
O&M Building	Semi-annually	<ul style="list-style-type: none"> • Check smoke detectors • Apply pesticides as necessary to control rodents and insects
	Annually	<ul style="list-style-type: none"> • Check weather stripping and door/window operation • Check emergency lighting • Inspect electrical service panel
Backup Power	Annually	<ul style="list-style-type: none"> • Visually inspect backup power system • Perform functional test of backup power system
Fencing	Quarterly (and after heavy rain)	<ul style="list-style-type: none"> • Inspect fence or vandalism and erosion at base

SECTION 5

Environmental Considerations

5.1 Site Characteristics and Potential Environmental Issues

The Project site is located within a variance area as analyzed in the Solar PEIS. This indicates that, based on the program-level review in the Solar PEIS, the project site does not contain any major constraints to for utility-scale solar energy development; such development is permitted subject to site-specific conditions of approval.

A detailed analysis of site characteristics and environmental considerations will be provided in the EIS for the project. Topics to be covered in the project's environmental analysis include, but are not limited to:

- Air Resources
- Areas of Critical Environmental Concern
- Cultural Resources; Native American Religious Concerns
- Wildlife; Migratory Birds; Threatened, Endangered, and Candidate Animal Species
- Vegetation; Forestry; Invasive and Noxious Weeds
- Geology and Mineral Resources
- Soil Resources
- Hazards and Hazardous Materials
- Lands/Access
- Military and Civilian Aviation
- Recreation
- Socioeconomics and Environmental Justice
- Transportation
- Visual Resources
- Water Resources

5.1.1 Potential Resource Conflicts

Native American Tribal Resources

A tribal resource is defined as a site, feature, place, cultural landscape, sacred place, or object with cultural value to a Native American Tribe. Federally recognized Native American Tribes are sovereign nations exercising government-to-government relations with the U.S. Government. The presence and location of potential Tribal resources would be determined through the cultural resource records search and through consultations between Tribes and the BLM Field Office manager throughout the NEPA process.

If necessary, a Cultural Resources Inventory would be completed on behalf of the Project. Inventories would be used by the BLM, in conjunction with Tribal consultations, to determine whether Tribal resources are identified within the project area. If Tribal resources are identified within the project area, construction activities would be designed to avoid those areas to the extent feasible, with the aim of resulting in no impacts. If Tribal resources cannot be avoided, mitigation may be required. Mitigation may include the presence of an authorized cultural resources monitor on-site during activities conducted within areas of known cultural resources.

Wildlife; Migratory Birds; Threatened, Endangered, and Candidate Animal Species

There are many reptiles, amphibians, insects, birds, and game and non-game species found in the Mojave Desert ecosystem. Although these species are important to the Mojave Desert ecosystem, they are not afforded any special protection. The following categories of wildlife may be impacted by development of the Project.

Avian Species: Avian species are protected under the Migratory Bird Treaty Act of 1918. Mortality of avian species is not anticipated to occur, though development of the project area may result in a loss of habitat. Impacts to avian species of concern would be addressed as necessary within the Bird and Bat Conservation Strategy (BBCS).

Golden Eagle: Impact to golden eagles would be addressed as necessary in a project-specific BBCS Plan. The development of this Project is not anticipated to have any impact or mortality of the golden eagle (*Aquila chrysaetos*). The development of the Project may result in a loss of foraging habitat. The BBCS would include measures to avoid, minimize, and mitigate impacts to birds, including golden eagles.

Threatened and Endangered Species

The Project is located in habitat for the federally threatened desert tortoise (*Gopherus agassizii*). Project development and operation may kill, injure, or displace individual desert tortoises. The development of the project would require the BLM to prepare a Draft BA in accordance with legal requirements set forth under Section 7 of the Endangered Species Act of 1973. The Draft BA would address the potential effects from implementation of the proposed project on the threatened desert tortoise. Project-specific mitigation measures would be identified within the BA and through consultation with

the USFWS, which would minimize impacts to the desert tortoise, and would be outlined in the Biological Opinion for the project.

Project-specific mitigation measures would include a Desert Tortoise Translocation Plan which provides the Desert Tortoise Safety and Avoidance Measures. Measures to minimize harm to translocated tortoises would be implemented in accordance with the approved BA and through consultation with the USFWS. These measures may include assigning USFWS Authorized Biologists to handle tortoises, translocating during USFWS-specified weather conditions, and taking measures to prevent disease transmission.

Vegetation; Forestry; Invasive and Noxious Weeds

General vegetation found in the project region consists mainly of Sonora-Mojave Creosote Bush (*Larrea tridentata*)-White Bursage (*Ambrosia dumosa*) Desert Scrub and Mojave Mid-Elevation Mixed Desert Scrub (U.S. Geological Survey). The creosote-bursage ecological system is found in broad valleys, lower bajadas, plains, and low hills in the Mojave Desert and lower Sonoran Desert. This system ranges from sparse to moderately dense layer (2%–50% cover). Creosote bush and white bursage are the typical dominant species, but a variety of shrub, dwarf-shrub, and cacti may be present or co-dominant.

Botanical surveys will be conducted on behalf of the project by BLM-approved botanists and biologists. The resulting data would be used to complete a project-specific botanical survey report. The botanical survey report would provide detail on vegetation and soil types and would provide discussion and recommendations for minimizing impacts to vegetation communities.

In addition to general vegetation, the BLM and the State of Nevada have protections in place for cactus, yucca, and Christmas tree species (NRS 527.060–537.120 and NAC Chapter 527). The BLM requires preparation of a Site Restoration and Revegetation Plan, which includes measures to salvage these species.

Invasive Plant Species and Noxious Weeds

The State of Nevada regulates invasive plant species through NRS 555.005–201. These statutes require the State Quarantine Office to determine which non-native species would be defined as invasive or “noxious” and regulated. These species are categorized in accordance with NAC 555.010 and are listed online at the Nevada Department of Agriculture Nevada Noxious Weed List website (Nevada Department of Agriculture 2020).

Botanical surveys will be conducted on behalf of the project by BLM-approved botanists and biologists. This Project area is known to have exotic plant species such as: redbrome (*Bromus madritensis* ssp. *rubens*), cheatgrass (*Bromus tectorum*), and Mediterranean grass (*Schismus barbatus*).

In order to reduce potential colonization of invasive plants and noxious weed species, a Site Restoration and Revegetation Plan, Invasive Plant Species and Noxious Weed Management Plan would be developed for the project and implemented during project construction and restoration activities. These plans would include BLM-approved mitigations and industry-standard best management practices with the intent to avoid impacts of these plant species during project construction and operation. In order to reduce potential impacts to native species, revegetation will occur immediately following construction and replanted and or re-seeded with native plants in order to begin the restoration process and prevent invasive species from dominating the site. New infestations of non- native and invasive species would be treated in accordance with the Invasive Plant Species and Noxious Weed Management Plan.

5.2 Other Uses on the Project Site

There are no other known uses on the project site.

5.2.1 Military Aviation

The Project site is not located under any military airspace or in a DoD Consultation Area. Because the Project would not construct facilities taller than 200 feet, it would not require FAA evaluation of safety hazards. However, as described in the Solar PEIS, the military has indicated that structures higher than 50 feet within the vicinity of any base may present electromagnetic compatibility concerns for test missions. The Project's collector and gen-tie lines would exceed this height. Consultation with DoD would occur during the EIS process. An Obstacle Evaluation analysis will be submitted to the Federal Aviation Administration (FAA) which would include coordination with the DoD.

5.3 Design Features

The BLM's decision in the Solar PEIS ROD includes amending land use plans in the six-state study area with: (1) programmatic design features that would be required for all utility-scale solar energy projects on BLM-administered lands; and (2) SEZ-specific design features that would be required for projects in individual SEZs. The Applicant will incorporate the following management plans to be prepared for BLM approval. These plans will be prepared subsequent to issuance of a ROD supporting the issuance of a ROW grant for the Project:

- Bird and Bat Conservation Strategy
- Decommissioning and Site Reclamation Plan
- Dust Abatement Plan
- Spill Prevention and Emergency Response Plan
- Health and Safety Program
- Groundwater Monitoring and Reporting Plan
- Fire Management Plan
- Lighting Management Plan

- Integrated Weed Management Plan
- Site Rehabilitation and Restoration Plan
- Stormwater Pollution Prevention Plan
- Site Drainage Plan
- Traffic Management Plan
- Surface Water Quality Management Plan
- Worker Environmental Awareness Program (WEAP)

5.4 Mitigation Measures

The following are preliminary Applicant-proposed mitigation measures. These measures are subject to change based on the findings of site-specific technical analyses, the analysis in the EIS, and BLM's decision in the project's ROD.

5.4.1 Migratory Birds

- To prevent undue harm, habitat-altering projects or portions of projects should be scheduled outside bird breeding seasons. In upland desert habitats and ephemeral washes containing upland species, this season generally occurs from March 1 through August 31. During breeding season, a qualified biologist would survey the area for nests prior to commencement of construction activities. This shall include burrowing and ground-nesting species, in addition to those nesting in vegetation. If any active nests (containing eggs or young) are found, an appropriate buffer around the nest must be avoided until the young birds fledge.
- During construction in migratory bird season, the Authorized Biologist would clear ahead of the construction crews and flag and monitor any active nests found. If active nests are found within the construction zone, construction would only occur outside the buffer zone, until the nest is inactive.

5.4.2 Cultural Resources

- Cultural resources are defined as buildings, sites, structures, or objects, each of which has historical, architectural, archaeological, cultural, and/or scientific importance. Numerous laws, regulations, and statutes, on both the federal and State levels, seek to protect and target the management of cultural resources.
- In consultation with BLM and with SHPO concurrence, any areas which contain cultural resources of significance or whose eligibility for inclusion on the National Register of Historic Places (NRHP) is unevaluated, would be avoided, mitigated, or "treated" and recorded as appropriate. Applicant employees, contractors, and suppliers would be reminded that all cultural resources are protected and if uncovered, the resource shall be left in place, work would cease, and notification would be made to the Applicant

representative and the appropriate BLM authorized office, with written confirmation to follow, immediately upon such discovery.

- If construction occurs in proximity to an NRHP-eligible cultural resource site, Applicant would have an authorized cultural monitor on-site during the activity.

5.4.3 Reclamation

- Also refer to Section 1.3.14, Vegetation Management and Section 1.3.14.1, Noxious Weed and Pest Control. For areas that have required clearing and/or grading work, restoration and reclamation procedures would be based on site-specific requirements and techniques commonly employed at the time the area is to be reclaimed and would include regrading, top soiling, and revegetating all disturbed areas. Topsoil from all decommissioning activities shall be salvaged and reapplied during final reclamation. All areas of disturbed soil shall be reclaimed using weed-free native shrubs, grasses, and/or forbs. Vegetation cover, composition, and diversity shall be restored to values commensurate with the ecological setting.
- Reclamation would be conducted on all disturbed areas to comply with BLM requirements. The short-term goal of reclamation would be to stabilize newly disturbed areas as rapidly as possible, thereby protecting sites and adjacent undisturbed areas from degradation. The long-term goal would be to return the land to approximate pre-disturbance conditions.
- After construction is complete, disturbed work areas would be graded to the approximate original contour, and the area would be revegetated with BLM-approved seed mixtures. Most postconstruction work would entail scarifying soils to reduce compaction and reseeding. Since only certain areas along the total Applicant project alignment will be disturbed, a specific Site Restoration/Revegetation and Decommissioning Plan would be prepared that describes the recommendations for each area.

5.5.4 Weed Management

Noxious weeds within the construction area are to be addressed by the initiation of mitigation measures in consultation with the BLM noxious weed management specialists. The BLM would require ROW monitoring and noxious weed abatement prior to and following construction. Applicant would develop a project-specific Weed Management Plan prior to issuing any permits or undertaking construction. The Weed Management Plan would include preventive measures, treatment methods, and monitoring activities. At a minimum, the Weed Management Plan shall include the following preventive measures:

- All contractor vehicles and equipment would arrive at the work site clean and weed free.
- Prior to being allowing access to vehicles and equipment in the ROW or ancillary facilities, an inspector would ensure that vehicles and equipment are free of soil and debris capable of transporting noxious weed seeds, roots, or rhizomes.

- The distribution line ROW and ancillary facilities would be inspected for noxious weeds prior to vegetation clearing on the ROW and ancillary facilities. Any infestations would be recorded for reference in clearing the ROW and ancillary facilities for construction and for post-construction monitoring.
- In areas where infestations have been identified or noxious weeds were noted in the field, the contractor would stockpile cleared vegetation and salvaged topsoil adjacent to the area from which they are stripped to eliminate the transport of soil-borne noxious weed seeds, roots, or rhizomes. During reclamation, the contractor would return topsoil and vegetative material from infestation sites to the areas from which they were stripped.
- The contractor would implement the reclamation of disturbed lands following construction as outlined in the Reclamation Plan.
- Continuing revegetation efforts would ensure adequate vegetative cover to prevent the invasion of noxious weeds.
- The contractor would ensure that straw bales used on the project for sediment barrier installations or mulch distribution are certified weed-free.
- Equipment would not be sprayed with pre-emergent chemicals as a preventive measure, as these chemicals target a wide range of vegetation. As a result, the use of such chemicals could affect the success of revegetation efforts.
- Field wash stations would not be used as a preventive measure, as they have not proven to be an effective means of weed control.

5.5.5 Air Quality

- Water would be applied to the ground during the construction and use of the project area, access roads, and other disturbed areas as necessary to control dust.
- A fugitive dust permit from Clark County for construction activities would be obtained prior to construction, and requisite dust control measures and BMPs would be implemented during the proposed project.

5.5.6 Fire Protection

- All federal, State, and county laws, ordinances, rules, and regulations that pertain to prevention, pre-suppression, and suppression of fire would be strictly adhered to. All personnel would be advised of their responsibilities under the applicable fire laws and regulations. It would be the responsibility of the construction crews to notify the agencies when a project-related fire occurs within or adjacent to the construction area.
- The construction crews would be responsible for any fire started, in or out of the project area, by their employees or operations during construction. The contractor would be responsible for fire suppression and rehabilitation. The crews would take aggressive action

to prevent and suppress fires on and adjacent to the project area and would use their workers and equipment on the project for fighting fires within the project area.

SECTION 6

References

- Avian Power Line Interaction Committee (APLIC), 2006. Suggested Practices for Avian Protection on Power Lines. [[http://www.aplic.org/uploads/files/2643/SuggestedPractices2006\(LR-2\).pdf](http://www.aplic.org/uploads/files/2643/SuggestedPractices2006(LR-2).pdf)].
- BLM, 2014a. Dry Lake Solar Energy Zone Auction Selects Three Potential Developers. June 30, 2014. [http://www.blm.gov/nv/st/en/info/newsroom/2014/june/southern_Nevada_4.html].
- BLM, 2014b. Regional Mitigation Strategy for the Dry Lake Solar Energy Zone. Technical Note 444. March 2014 [http://www.blm.gov/style/medialib/blm/wo/blm_library/tech_notes.Par.29872.File.dat/TN_444.pdf].
- BLM, 2012a. Approved Resource Management Plan Amendments/Record of Decision (ROD) for Solar Energy Development in Six Southwestern States. October 2012. [solareis.anl.gov/documents/docs/Solar_PEIS_ROD.pdf].
- BLM, 2012b. Solar Energy Plan of Development Outline. December 19, 2012.
- BLM, 2010. Record of Decision – Approved Resource Management Plan: Bradshaw-Harquahala. April 22, 2010. [https://eplanning.blm.gov/epl-front-office/projects/lup/1350/13345/13413/Bradshaw-Harquahala_Record_of_Decision_and_Approved_Resource_Management_Plan_pdf.pdf]
- BLM, 2007a. Final Programmatic Environmental Impact Statement (PEIS) for Vegetation Treatments on Bureau of Land Management Lands in 17 Western States. June 29, 2007. [http://www.blm.gov/wo/st/en/prog/more/veg_eis.html].
- BLM, 2007b. Record of Decision (ROD) for Vegetation Treatments on Bureau of Land Management Lands in 17 Western States September 2007. [http://www.blm.gov/style/medialib/blm/wo/Planning_and_Renewable_Resources/veis/dear_reader_letter.Par.95872.File.dat/RecordofDecision.pdf].
- BLM, 2007c. Partners Against Weeds. [http://www.nv.blm.gov/Resources/noxious_weeds.htm].
- BLM, 2006. Noxious Weed Plan. U.S. Bureau of Land Management, Phoenix Field Office.
- BLM and U.S. Department of Energy (DOE), 2012. Final Programmatic Environmental Impact Statement (PEIS) for Solar Energy Development in Six Southwestern States (FES 12-24; DOE/EIS-0403) July 2012 [<http://solareis.anl.gov/Documents/fpeis/index.cfm>].

BLM and DOE, 2011. Supplement to the Draft Programmatic Environmental Impact Statement for Solar Energy Development in Six Southwestern States, DES 11-49, DOE/EIS-0403D-S, Oct.

BLM and DOE, 2010. Draft Programmatic Environmental Impact Statement for Solar Energy Development in Six Southwestern States, Chapter 5. December 2010. [<http://solareis.anl.gov/Documents/dpeis/index.cfm#vol5>].

ATTACHMENT A
Preliminary Site Plan

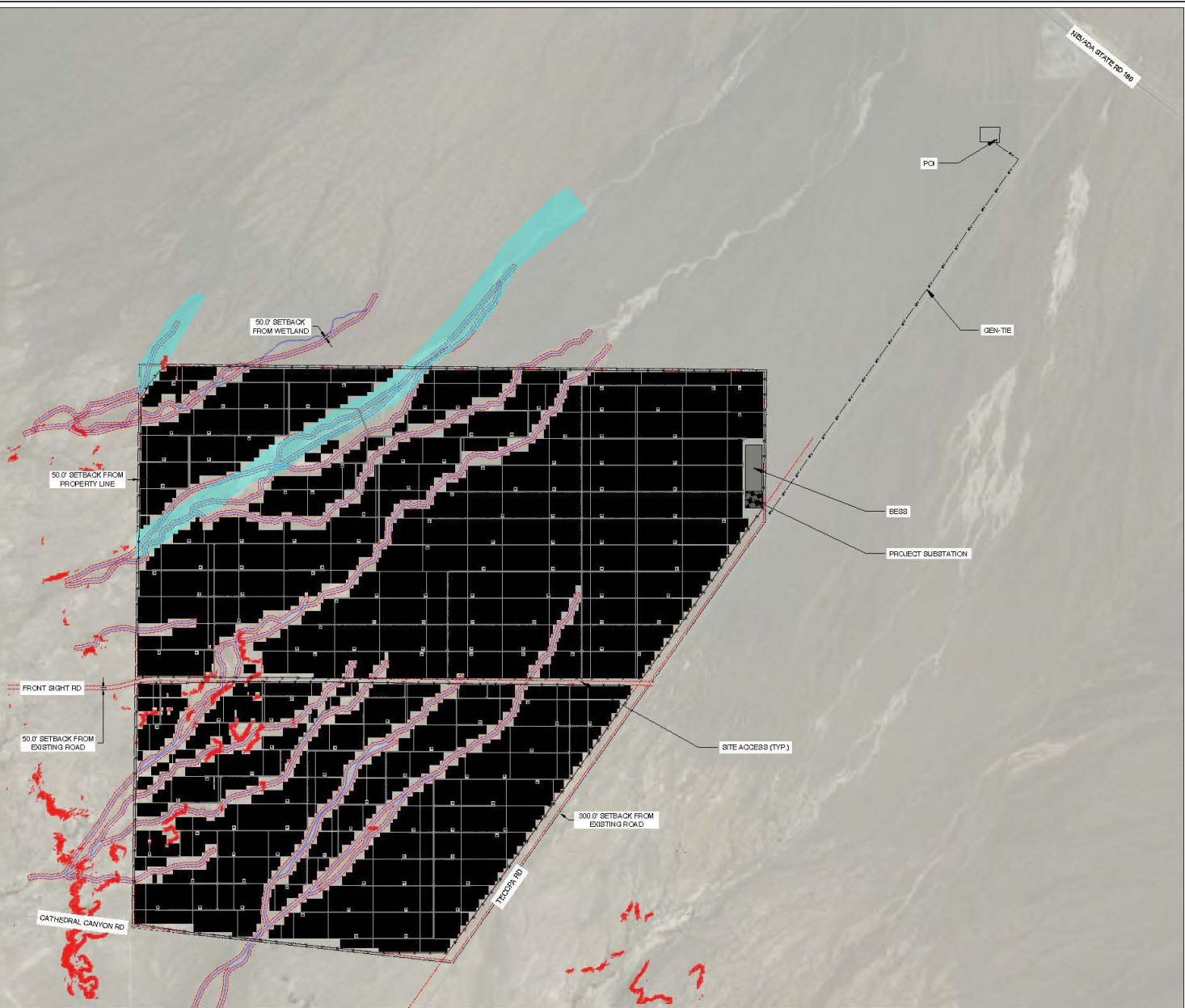

SY
SYSTEM SIZE @ DC
SYSTEM SIZE @ FIELD
SYSTEM SIZE @ PCI
DC/AC RATIO @ FIELD (L/R)
DC/AC RATIO @ PCI
MODULE MANUFACTURER
MODULE MODEL
MODULE RATING
TOTAL MODULE QTY
MODULES PER STRING
TOTAL NO. OF STRINGS
INVERTER MODEL
INVERTER RATING
INVERTER QTY
STEP-UP TRANSFORMER
RACKING
INTER-ROW SPACING
PITCH
GOR
SITE AREA INSIDE FENCE

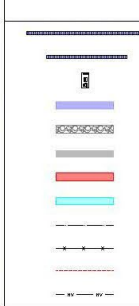

1. INSTALLATION TO COMPLY WITH STATE AND NATIONAL CODES
2. EQUIPMENT SHALL BE LABELED
3. 20' ACCESS ROADS SHALL BE MAINTAINED FOR OPERATIONS, MAINTENANCE
4. DIMENSIONS TO PROPERTY PENDING SURVEY.

PROPERTY BOUNDARY TO FENCE
 WETLAND TO FENCE
 CENTERLINE OF ROAD TO FENCE

1 ARRAY PLAN
 SCALE: 1" = 1,300'