



United States Department of the Interior

BUREAU OF LAND MANAGEMENT

Colorado State Office
2850 Youngfield Street
Lakewood, Colorado 80215-7210
www.co.blm.gov



MAY 19 2014

In Reply Refer To:
3160 (CO-922)

Dear Colorado Oil and Gas Lessee/Operator:

Enclosed is a copy of Colorado Notice to Lessee (NTL-CO) 2014-01 to inform Federal and Indian Lessees/Operators of the Bureau of Land Management (BLM) of the minimum standards for isolating flow conditioners used on the upstream side of a gas meter run to reduce swirl and/or asymmetric flow in the natural gas. Effective immediately, isolating flow conditioners that meet these standards are approved for use on all Federal and Indian oil and gas leases located within the jurisdiction of the BLM Colorado State Office (COSO).

If you have any question please contact Pat Gallagher, Petroleum Engineer, at (303) 239-3756.

Sincerely,



Ruth Welch
State Director

Enclosure

UNITED STATES
DEPARTMENT OF THE INTERIOR
BUREAU OF LAND MANAGEMENT

Notice to Lessees/Operators of Onshore Federal and Indian
Oil and Gas Leases within the Jurisdiction of the
Colorado State Office
NTL CO-2014-01

Standards for the Use of Isolating Flow Conditioners
in Meter Runs for Gas Measurement

This notice is to inform Federal and Indian lessees/operators of the minimum standards for isolating flow conditioners used on the upstream side of the meter run to reduce swirl and/or asymmetric flow in the natural gas. Isolating flow conditioners that meet these standards are approved for use on all Federal and Indian points of royalty settlement (points of measurement) for oil and gas leases located within the jurisdiction of the Colorado State Office (COSO).

For the purpose of this NTL, an “*isolating flow conditioner*” is a device that reduces swirl and/or asymmetric flow in natural gas and is fitted inside a meter run upstream of a flange-tapped orifice meter. Tube bundles or straightening vanes constructed and installed in accordance with American Gas Association (AGA) Committee Report No. 3 (1985) and Onshore Oil and Gas Order No. 5 (OO #5) are not considered isolating flow conditioners and are not addressed in this NTL.

The requirements of this NTL implement the existing requirements in OO #5 specifically section III. C. 3. This NTL does not alter the standards and requirements of OO #5, or applicable variances. Any meter runs installed after the effective date of this NTL that use isolating flow conditioners and meet the standards in this NTL are considered in compliance with OO #5. All meter runs using isolating flow conditioners installed prior to the effective date of this NTL must meet the standards of this NTL within the timeframes specified below to be in compliance with this NTL (all timeframes are from the effective date of this NTL):

- 3 months for isolating flow conditioners installed in meter runs measuring, on average, more than 500 Mcf/day on a monthly basis;
- 6 months for isolating flow conditioners installed in meter runs measuring, on average, equal to or more than 100 Mcf/day but no more than 500 Mcf/day on a monthly basis; and
- 1 year for isolating flow conditioners installed in meter runs measuring, on average, less than 100 Mcf/day on a monthly basis.

This NTL is based on a review by the Bureau of Land Management (BLM) of isolating flow conditioner test data. If the BLM determines that the isolating flow conditioner installed does not perform as claimed by the manufacturer, the BLM may require retrofit of the isolating flow conditioner installation or the installation of a meter run that complies with AGA Committee Report No. 3 (1985).

Minimum Standards

1. Only those makes and models of isolating flow conditioners that comply with the following conditions are approved for use on Federal and Indian leases within Colorado:
 - a. The make and model of isolating flow conditioner has undergone type approval testing in accordance with American Petroleum Institute (API) Chapter 14, Section 3, Part 2, Appendix 2-D (April 2000);
 - b. The flow test data generated as part of the testing in paragraph 1.a. has been provided to the BLM; and
 - c. The make and model of isolating flow conditioner is listed in Attachment 1 to this NTL. Attachment 1 is updated as different types of flow conditioners are allowed by the BLM. For the most up-to-date Attachment 1, please go to the BLM Colorado homepage and select "What We Do" then select "Energy" then select "Oil and Gas" then select "Regulations and Enforcement". Scroll down and select "Standards for the Use of Isolating Flow Conditioners in Meter Runs for Gas Measurement" at http://www.blm.gov/co/st/en/BLM_Programs/oilandgas/leasing_regulations.html.
2. Isolating flow conditioners must be installed per the manufacturer's specifications (see Attachment 1).
3. With the use of isolating flow conditioners, the thermometer well must be placed downstream of the orifice in accordance with AGA Committee Report No. 3 (1985).
4. Information on the make, model, size, and location of the isolating flow conditioner must be maintained on-site. The information must be in an obvious location, so any BLM inspector can verify the installation and meter run lengths.

Variations from Requirements or Minimum Standards

The operator may make a written request for a variance from this NTL to the BLM Field Office. A request for a variance must explain the reason the variance is needed and demonstrate how the operator will satisfy the intent of this NTL. A variance from the requirements of this NTL does not constitute a variance to provisions of other regulations, laws, or orders. The decision whether to grant or deny the variance request is entirely within the BLM's discretion. The decision on a variance request is not subject to administrative appeals either to the State Director or pursuant to 43 C.F.R. part 4.

1 Attachment:

Installation Specifications for Approved Isolating Flow Conditioners,
August 4, 2013 (3 pp)

Installation Specifications¹ for One-Piece Isolating Flow Conditioners

“Pinned” Installations

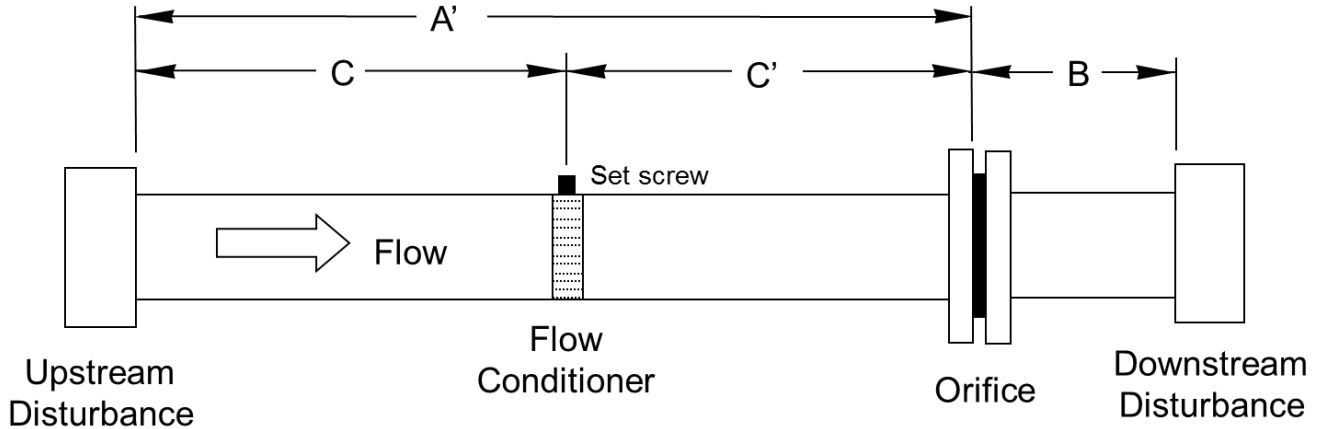

Identifying Information			Installation Requirements			
Manufacturer	Model	A' Min	C Min/max	C' Min/max	B	Comments
CPA	50E - TBR	13	5/-	8/-	AGA 3	
		17	4/-	7/-	AGA 3	$\beta \leq 0.67$
Savant	pFC	10	5/-	5/11	AGA 3	2" - 4"; $\beta \leq 0.67$
		13	8/-	5/11	AGA 3	2" - 4"; $\beta > 0.67$
Canalta	K5P	13	5/-	8/-	AGA 3	
		17	4/-	7/-	AGA 3	$\beta \leq 0.67$

¹Specifications are from the manufacturer and have not been independently verified by BLM as of 8/24/12
 Note: All dimensions are given in internal pipe diameters (D_i); A “-“ indicates that there is no maximum value specified

Flanged Installations

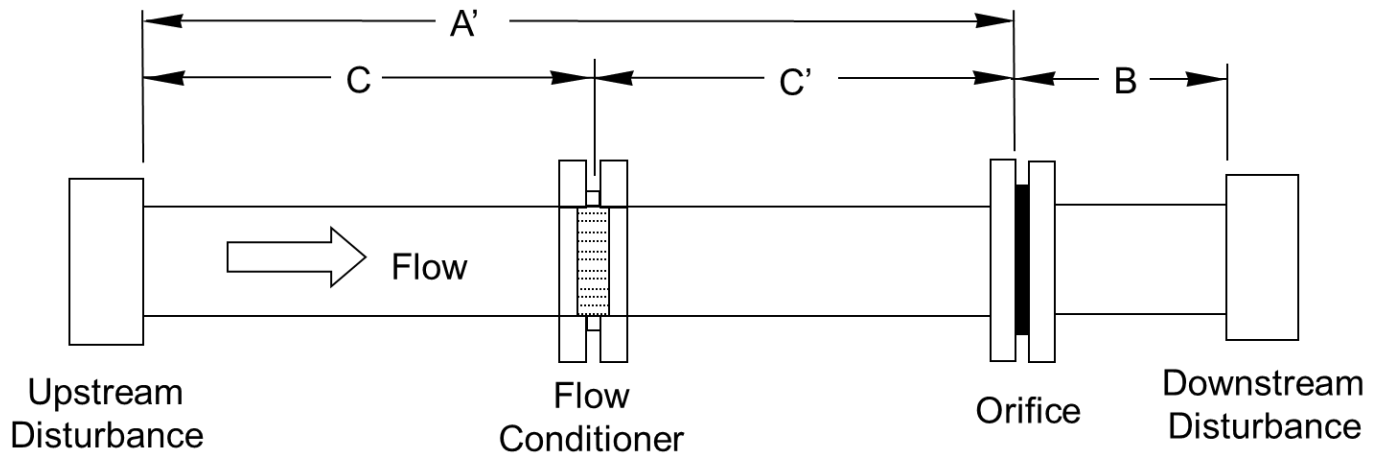

Identifying Information			Installation Requirements			
Manufacturer	Model	A' Min	C Min/max	C' Min/max	B	Comments
CPA	50 E – A/B	13	5/-	8/-	AGA 3	
		17	4/-	7/-	AGA 3	$\beta \leq 0.67$
Daniel	Profiler	17	9.5/-	7.5/-	AGA 3	
Savant	pFC-F and GFC-Paddle	10	5/-	5/11	AGA 3	2" - 4"; $\beta \leq 0.67$
		13	8/-	5/11	AGA 3	2" - 4"; $\beta > 0.67$
Canalta	K5F	13	5/-	8/-	AGA 3	
		17	4/-	7/-	AGA 3	$\beta \leq 0.67$

¹Specifications are from the manufacturer and have not been independently verified by BLM as of 8/24/12
 Note: All dimensions are given in internal pipe diameters (D_i); A “-“ indicates that there is no maximum value specified

Installation Specifications¹ for Two-Piece Isolating Flow Conditioners

Savant GFC Sys I Installations

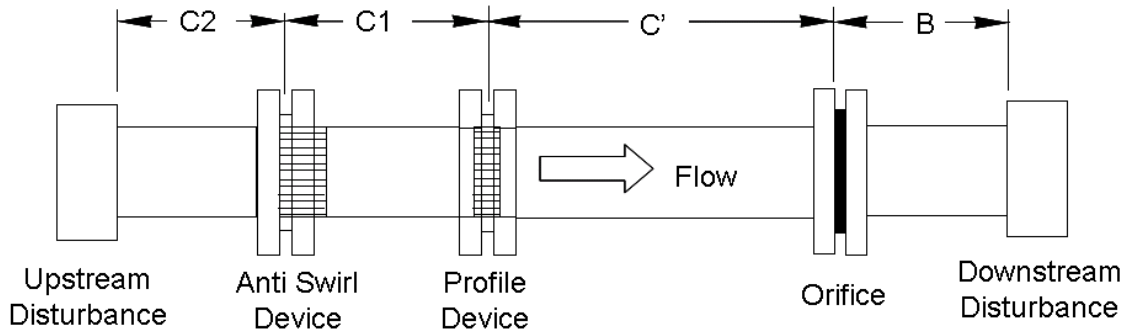

Savant GFC Sys II Installations

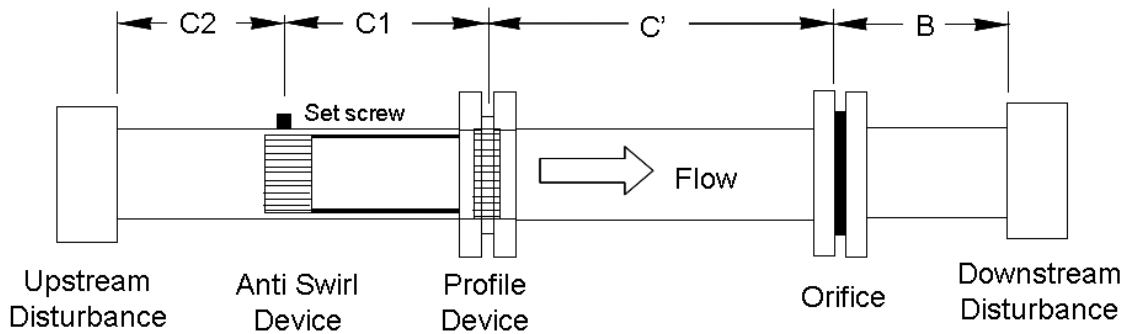

Savant GFC Sys III Installations

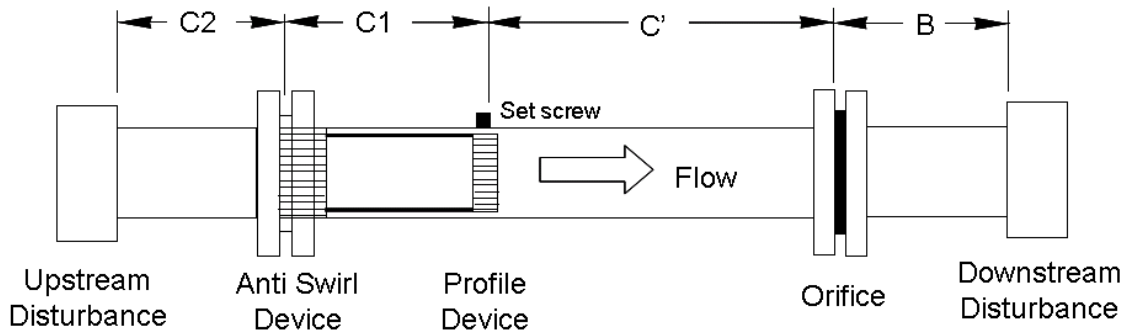

Savant GFC Sys IV Installations

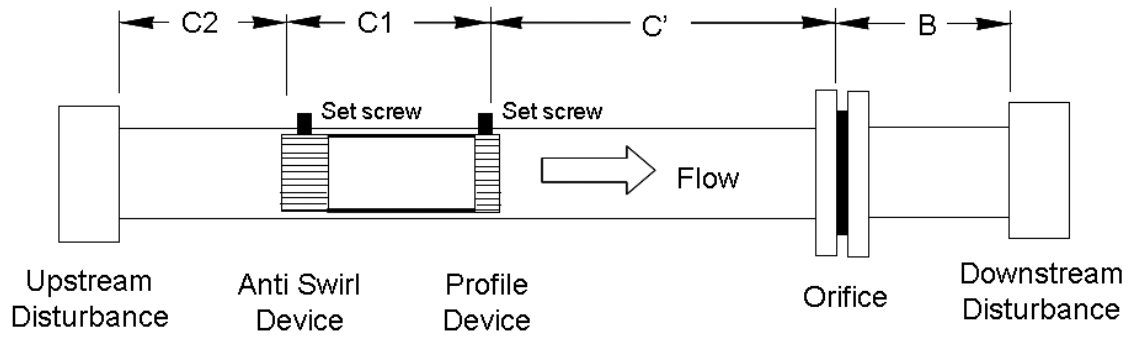

Savant GFC Sys XI Installations

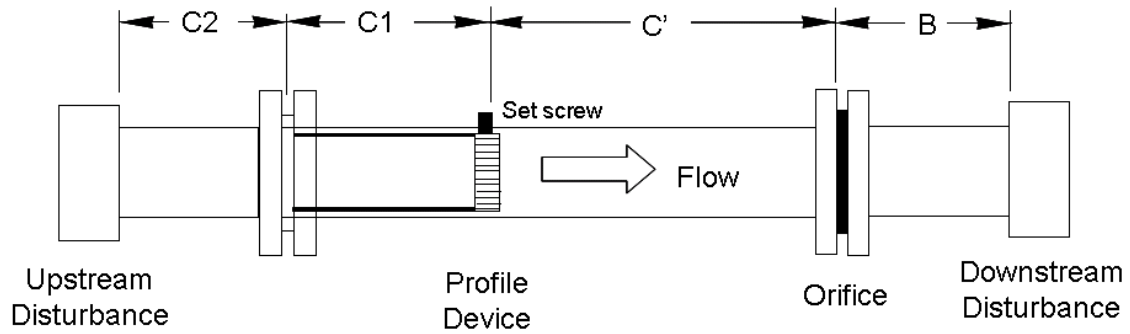

Manu- facturer	Model	C2 Minimum	C1 Minimum	C' Minimum	B	Comments
Savant	GFC Sys I	3	3.5	5	AGA 3	
	GFC Sys II	3	3.25	5	AGA 3	
	GFC Sys III	3	3.5	5	AGA 3	
	GFC Sys IV	3.25	3.25	5	AGA 3	
	GFC Sys XI	3	3.5	5	AGA 3	<1.939" only

¹Specifications are from the manufacturer and have not been independently verified by BLM as of 8/24/12
 Note: All dimensions are given in internal pipe diameters (D_i)