

UNITED STATES  
DEPARTMENT OF THE INTERIOR  
BUREAU OF LAND MANAGEMENT  
Salem District Office  
1717 Fabry Road, S.E.  
Salem, Oregon 97306

ORS040-TS12- 502  
Powermill Timber Sale

Date: May 25, 2012

PROSPECTUS  
SBA SET-ASIDE

THIS IS A PROSPECTUS ONLY. ATTACHMENTS MAY NOT INCLUDE ALL EXHIBITS REFERRED TO IN THE CONTRACT. THE COMPLETE CONTRACT, INCLUDING ALL EXHIBITS, IS AVAILABLE FOR INSPECTION AT THE SALEM DISTRICT OFFICE.

NOTICE IS HEREBY GIVEN that the Bureau of Land Management will offer for sale timber as described herein for oral auction, pursuant to Instructions to Bidders, as stated on Form No. 5440-9 and subject to Notice of Requirement for Certification of Nonsegregated Facilities, Form No. 1140-4, attached. Written and oral bids will be received by the District Manager, or his representative, in the timber sale room at the District Office, 1717 Fabry Road, S.E., Salem, Oregon. The timber sale will commence at 9:00 a.m., on Wednesday, June 27, 2012.

THIS TIMBER SALE NOTICE does not constitute the decision document for purposes of protest and appeal of a forest management decision. Consistent with 43 CFR Subpart 5003-Administrative Remedies, the notice of a timber sale, when published as a legal ad in a newspaper of general circulation shall constitute the decision document for purposes of protest and appeal. Protests may be filed with the Contracting Officer within 15 days of the publication of the aforementioned decision document in the newspaper. It is anticipated that the decision document will be published in the Stayton Mail on or about May 30, 2012. BLM does not warrant publication on this exact date. All parties considering protest of the timber sale decision document are encouraged to review the aforementioned newspaper(s) to ensure accurate knowledge of the exact publication date.

AN ENVIRONMENTAL ASSESSMENT was prepared for each timber sale tract, and a Finding of No Significant Impact has been documented. These documents are available for inspection as background for each timber sale tract at the Salem District Office.

FOR SBA SET-ASIDE TRACTS, the bidder must not have been determined by the Small Business Administration to be ineligible for preferential award for set-aside sales and must accompany his deposit with a self-certification statement that he is qualified as a small business concern as defined by the Small Business Administration in its regulations, Title 13, Chapter I, Part 121 (Revision 7) as amended, of the Code of Federal Regulations. The Form 5430-1 Self Certification Statement is attached hereto. The successful bidder will be required to sign SBA Form 723 "Small Business Certification Required on All Preferential Sales of Set-Aside Timber" at the time he signs the timber sale contract. Section 2(a) of Form 723 requires that successful bidders of SBA set-aside tracts must comply with delivery requirements pertaining to sawtimber volume. No more than 30% of the advertised sawtimber volume from a set-aside sale may be delivered for manufacturing to a business that is not a small business, as defined by the SBA (13 CFR 121.507 (a)). A copy of SBA Form 723 is attached.

A WRITTEN BID on Form 5440-9 at not less than the advertised appraised price on a unit basis per species and the required minimum bid deposit shall be required to participate in oral bidding.

THE SUCCESSFUL BIDDER, as a condition of award, will be required to sign Form 1140-6, a certification that the bid was arrived at by the bidder or offeror independently, and was tendered without collusion with any other bidder or offeror. Form 1140-7, Equal Opportunity Affirmative Action Program Representation, must be completed by the successful bidder for all contracts over \$10,000. Form 1140-8, Equal Opportunity Compliance Report Certification, must also be completed by the successful bidder. Form 5450-17, Export Determination, must be completed by the successful bidder. To expedite procedure, this form should be completed and submitted with the written bid.

THE VOLUMES LISTED herein are estimates only. The sale volumes listed are based on 16-foot taper breaks which must be taken into consideration if comparisons are made with volume predictions based on other standards. The volumes based on 32-foot taper breaks are shown for comparison purposes. No sale shall be made for less than the advertised appraised price. The Purchaser shall be liable for the total purchase price, without regard to the amount bid per unit, even though the quantity of timber

actually cut or removed or designated for taking is more or less than the estimated volume or quantity so listed.

THIS TIMBER SALE has been cruised based upon Eastside Scribner board foot measure. The minimum bid figures shown by species are dollars per thousand board feet (MBF). The minimum bid increment will be \$0.10 per MBF.

A PERFORMANCE BOND in an amount not less than 20 percent of the total purchase price will be required for all contracts of \$2,500 or more. A minimum performance bond of not less than \$500 will be required for all installment contracts less than \$2,500.

QUALIFIED SMALL BUSINESS concerns may apply to SBA for a loan to provide financing for access road construction required under the terms of qualifying timber sale contracts, and necessary contract changes will be made. Approval of loan applications rests with SBA and may be contingent on availability of funds. Applicants for such loans shall notify BLM of their intention to apply for a loan.

PRE-AWARD QUALIFICATIONS. The high bidder may be required to furnish information to determine the ability to perform the obligations of the contract. If the high bidder is determined not qualified, responsible or refuses to respond within fifteen (15) days of a request for information pertaining to qualifications, the contract may be offered and awarded for the amount of the high bid to the highest of the bidders who is qualified, responsible, and willing to accept the contract.

LOG EXPORT AND SUBSTITUTION: All timber sales, including timber from Federal rights-of-ways, shall be subject to the restrictions relating to the export and substitution of unprocessed timber from the United States in accordance with P.L. 94-165 and 43 CFR 5400 and 5420, as amended. The BLM has revised the log export restrictions special provision to reduce the log branding and painting requirements.

LOG EXPORT AND SUBSTITUTION RESTRICTIONS: Excepting Port-Orford-cedar, all timber offered for sale hereunder is restricted from export from the United States in the form of unprocessed timber and is prohibited from being used as a substitute for exported private timber. The BLM has revised the log export restrictions special provision to reduce the log branding and painting requirements. The new requirements include branding of one end of all logs with a scaling diameter of over 10 inches. All loads of 11 logs or more, regardless of the diameter of the logs, will have a minimum of 10 logs branded on one end. All logs will be branded on loads of 10 logs or less. One end of all branded logs will be marked with yellow paint. At the discretion of the Contracting Officer, the Purchaser may be required to brand and paint all logs. The Purchaser shall bear any increased costs for log branding and painting.

CONTRACT TERMINATION: A revised Special Provision has been added to the contract which enables the Contracting Officer to suspend the contract to facilitate protection of certain plant or animal species, and /or to modify or terminate the contract when necessary to:

1. Comply with the Endangered Species Act, or;
2. Comply with a court order, or;
3. Protect occupied marbled murrelet sites in accordance with the Standards and Guidelines of the Salem District Record of Decision (ROD) and Resource Management Plan (RMP), or;
4. Protect species which were identified for protection through survey and manage and/or protection buffer standards and guidelines established in the ROD and RMP.

This contract provision limits the liability of the Government to the actual costs incurred by the Purchaser which have not been amortized by timber removed from the contract area.

ADDITIONAL INFORMATION concerning this timber sale tract is available at the above District Office. A copy of the timber sale contract is also available for inspection at the District Office. The prospectus for this/these sale(s) is also available online at: <http://www.blm.gov/or/districts/salem/timbersales/index.php>. The prospectus includes maps and tables that cannot be made Section 508 compliant. For help with its data or information, please contact the Salem District Office at 503-375-5646.

**Attachments:**

- Form 1140-4
- Form 5450-17
- Form 5430-1
- SBA Form 723
- Form 5440-9

TIMBER SALE NOTICE

**THIS IS A SMALL BUSINESS SET-ASIDE SALE FOR PREFERENTIAL BIDDING BY SMALL BUSINESS CONCERNS AS DEFINED BY THE SMALL BUSINESS ADMINISTRATION.**

SALEM DISTRICT  
CASCADES RESOURCE AREA  
SALEM MASTER UNIT

SALE DATE: June 27, 2012

CONTRACT NO. ORS040-TS12-502, POWERMILL THINNING TIMBER SALE: MARION COUNTY, OREGON: O&C: ORAL AUCTION: BID DEPOSIT REQUIRED: \$152,800.00.

All timber designated for cutting on: Lots 1 and 2, N½NE¼, SW¼NE¼, E½NW¼, Section 11, SW¼NE¼ Section 13, E½NE¼ Section 25, T.9 S., R.2 E., W.M.; SW¼SW¼ Section 17, Lot 3, NE¼SW¼, W½SE¼ Section 19, W½SW¼, SE¼SW¼, Section 21, T. 9 S., R.3 E., W. M.

**THIS TIMBER SALE HAS BEEN CRUISED BASED UPON EASTSIDE SCRIBNER MEASURE.**

Minimum bid figures shown by species are dollars per thousand board feet (MBF). The minimum bid increment will be \$0.10 per MBF.

Approx. No. Merchantable Trees	Est. Vol. MBF 32' Log	Est. Vol. CCF	Species	Est. Vol. MBF 16' Log	Appraised Price Per MBF	Estimated Volume Times Appraised Price
26,737	5,267	10,990	Douglas-fir	6,159	\$234.40	\$1,443,200.80
2,510	395	918	Western hemlock	492	\$140.90	\$69,604.60
282	81	177	Grand fir	100	\$147.20	\$14,720.00
29,529	5,743	12,085	Totals	6,751		\$1,527,525.40

**LOG EXPORT AND SUBSTITUTION RESTRICTIONS:** All timber offered for sale hereunder is restricted from export from the United States in the form of unprocessed timber and also prohibited from substitution of exported private timber.

**CRUISE INFORMATION:** The timber volumes were based on a variable plot cruise of the three hundred fifty-four (354) acres of partial cut which includes variable plot cruise of the six (6) acres of low density thinning patches with the exception of Units 15, 16, and 17 which were 100% cruised. Eight (8) acres of Right of Way was 100% cruised using form class tables for estimating board feet volume of trees in sixteen (16) foot logs. None of the total sale volume is salvage material. With respect to merchantable trees of all species; the average tree is: 14.1 inches DBHOB; the average log contains 50 bd. Ft.; the total gross volume is approximately 6,982 MBF and 97% recovery is expected.

**CUTTING AREA:** Seventeen (17) units totaling approximately three hundred sixty-two (362) acres, of which approximately three hundred fifty-four (354) acres shall be partial cut and approximately eight (8) acres of right-of-way shall be clearcut. Acres shown on Exhibit A have been computed using a Trimble GEO XT Global Positional System receiver. Acreage was calculated based on Global Positioning System traverse procedures including differential correction. Acres of partial cut area are net timbered acres, existing and planned road rights-of-way acres were subtracted from traversed acres.

**DURATION OF CONTRACT:** Will be 36 months for cutting and removal of timber.

## LOCATION:

### To Units in Section 11:

- To Unit 1: From Mehama on Highway 22, travel approximately 0.8 miles and turn NE onto the North Fork road. Travel approximately 2.7 miles on the North Fork road and turn north onto the 9-2E-10.0 road (gated). Travel approximately 1.6 miles north on the 10.0 road to the NW corner of unit 1.
- To Units 2, 3, and 4: From Mehama on Highway 22, travel approximately 0.8 miles and turn NE onto the North Fork road. Travel approximately 4.4 miles and turn NE onto the House Mountain road (9-2E-12.0 road - gated). Travel approximately 0.5 miles on the 12.0 road and turn west onto the 9-2E-12.1 road. You can drive approximately 0.2 miles West on the 12.1 road. The remaining access along the 12.1 road is a walk-in to the southern portions of units 3 and 2, and a long walk (approximately 2 miles) to unit 4. There is a large wash-out along the N/S property line of sections 11 and 12 where Kiel Creek crosses the 12.1 road.
- To Unit 5 From Mehama on Highway 22, travel approximately 0.8 miles and turn NE onto the North Fork Road. Travel approximately 4.4 miles and turn NE onto the House Mountain Road (9-2E-12.0 road - gated). Travel approximately 0.6 miles on the 12.0 road and turn west on the 9-2E-12.3 road. Travel on the 12.3 road for approximately 0.8 miles and turn NW on the 9-2E-12.4 road. Travel another 0.2 miles and turn SW on the 9-2E-1.6 road. After approximately 0.2 miles on the 1.6 road you should find the junction of the 9-2E-12.2 road leading South into unit 5. The 12.2 road is staked, and currently a walk-in.

To Unit in Section 13: From Mill City on Highway 22 turn north on 4<sup>th</sup> Street to Hudel road for approximately 2.1 miles. Turn east through a gate onto the 9-3E-10.0 road. Travel west on 9-3E-19 road for approximately 1.2 miles, to the 9-2E-13.0 road junction. Turn north on the 13.0 road, travel 0.2 mile to access the start of the staked Right-of-Way into unit 6.

To Units in Section 17: From Mill City on Highway 22, turn north on 4<sup>th</sup> Street onto Hudel Road for approximately 2.1 miles. Turn east through a gate onto the 9-3E-10.0 road. Take an immediate right onto the 9-3E-19.1 road. Travel east on 9-3E-19.1 road for approximately 0.6 miles to enter the SW corner of unit 8.

To Units in Section 19: From Mill City on Highway 22, turn north on 4<sup>th</sup> Street onto Hudel Road and travel for approximately 1.4 miles to the staked Right-of-Way for access to unit 14. Another 0.2 miles up Hudel road is the junction of the 9-3-19.3 road (gated) that leads into units 10 and 11. The 19.3 road is drivable for approximately 0.2 miles – the rest of the road is a walk-in.

To Unit in Section 21: From Mill city on Highway 22 turn north on 4<sup>th</sup> Street to Hudel road for approximately 0.7 miles. Turn East on the 9-3E-29.0 road (gated) and travel for approximately 1.2 miles to the western edge of unit 9.

To Units in Section 25: From the Fisherman's Bend turnoff on Highway 22 (West of Mill City) travel approximately 0.6 miles. Turn North on the 9-3E-30.0 road (gated) and travel approximately 0.4 miles to the eastern edge of unit 17.

## ACCESS AND ROAD MAINTENANCE:

Gate keys are required for access. Prospective bidders may obtain a key from the Salem District Office, Monday through Friday from 7:45 a.m. to 4:30 p.m. CREDIT CARD is required at the time of checking out a key. A \$50.00 charge will apply if key is not returned. **The 9-2E-11.1 road has a natural road surface and will be foot traffic only during the bidding period.**

In the use of the Bureau of Land Management controlled roads which the Purchaser is authorized to use, the Purchaser shall pay a rockwear obligation of One thousand seventy-seven and 30/100 dollars, (\$1,077.30) to the Bureau of Land Management. The Purchaser is required to maintain all Bureau of Land Management controlled roads as indicated on Exhibit E map.

In the use of Freres Timber, Inc. controlled roads which the Purchaser is authorized to use, the Purchaser shall enter into a license agreement with Freres Timber, Inc. and pay to Freres a road use fee of Nine thousand eight-hundred eighteen and 00/100 dollars, (\$9,818.00) and a road maintenance and rockwear fee of Four thousand three-hundred sixty-three and 97/100 dollars, (\$4,363.97). The Purchaser is required to carry liability insurance with limits of \$1,000,000/\$2,000,000/\$2,000,000 and a \$5,000.00 performance bond.

In the use of Frank Timber Resources, Inc. controlled roads which the Purchaser is authorized to use, the Purchaser shall enter into a license agreement with Frank Timber Resources, Inc. and pay to Frank a road use fee of Five hundred twenty-seven and 16/100 dollars, (\$527.16), maintain the roads and place 20 cy of truck measure surface rock in lieu of a rockwear fee. The Purchaser is required to carry liability insurance with limits of \$1,000,000/ \$1,000,000/\$1,000,000 and a \$2,000.00 performance bond.

In the use of Weyerhaeuser Company controlled roads which the Purchaser is authorized to use, the Purchaser shall enter into a license agreement with Weyerhaeuser Company and pay to Weyerhaeuser a road use fee of Four hundred seventy and 00/100 dollars, (\$470.00), maintain the roads and place 10 cy of truck measure surface rock in lieu of a rockwear fee. The Purchaser is required to carry liability insurance with limits of \$1,000,000/\$1,000,000/\$1,000,000 and a \$1,000.00 performance bond.

In the use of Oregon Department of Forestry controlled roads which the Purchaser is authorized to use, the Purchaser shall enter into a license agreement with Oregon Department of Forestry and maintain the roads. The Purchaser is required to carry liability insurance with limits of \$1,000,000/ \$1,000,000/ \$1,000,000.

In the use of easement for 9-3E-29 B, D, F2, G road which the Purchaser is authorized to use, the Purchaser is responsible for the maintenance to the road during use under the sale.

Purchaser maintenance shall include frequent blading and shaping of road surface; spot rocking; ditch, culvert, and catch basin cleaning; removal of minor slides and other debris. Roads shall be left in a condition to withstand adverse weather at the end of the seasonal operations.

Alternate access is available but will require a contract modification. Contact District personnel for more detailed information.

**ROAD CONSTRUCTION AND RENOVATION:** The Purchaser will be required to do all work set forth below. The Purchaser shall supply all materials unless otherwise indicated.

a. **Road Construction:**

Road P1 thru P12 = 128+34 stations of subgrade, insloped and outsloped,  
Surfacing – dirt, Usable width 12 feet.

b. **Renovation:**

Renovate 7.38 miles of BLM, State Forestry and Private road. Renovation will include but not be limited to reshaping of roadway, removing merchantable trees from rights-of-way, roadside brushing,

blading, spot rocking, compaction, spot ditch cleaning where needed, and cleaning inlet and outlet barrel of existing culverts as needed.

c. Estimated Quantities:

Clearing:

5.89 acres of new construction

0.50 acres of grubbing on new construction and reopening of existing

Excavation:

5900 cubic yards of common

Culvert and Flume:

30 feet of 18 inch corrugated-polyethylene or aluminized steel

252 feet of 24 inch corrugated-polyethylene or aluminized steel

20 feet of 24 inch corrugated-polyethylene single wall, or aluminized steel as down spout

190 feet of 36 inch corrugated-polyethylene or aluminized steel

30 feet of 48 inch aluminized steel

12 culvert markers

Aggregate Material:

Quantity

1695 cubic yards (truck measure)

Description

1½" minus crushed rock

Rock Source: Commercial Source X-Rock

e. Miscellaneous Items:

Right-of-way Debris Disposal:

Debris shall be disposed of by scattering on BLM

OTHER:

- Contact 811 to locate buried utilities along Hudel County Road.
- In water work for culvert installation is June 1 – October 15 with the exception of culverts #5, 6 and 7 which will be July 15 – August 31.
- Remove old gate and install new gate on 9-3E-19.3.
- Construct 10 barricades as shown on Exhibit E.
- Waterbar 3.91 miles of road as shown on Exhibit E.
- Decompect, waterbar and place slash on 0.87 miles of road as shown on Exhibit E.
- Remove culverts on road P12 as shown on Exhibit C.
- Dust control on road 9-3E-30 for 0.11 mile.

**SPECIAL ATTENTION ITEMS:**

- Sec. 40. Reserve trees
- Sec. 41.j-k. Special Yarding Requirements
- Sec. 41.l. Seasonal Restrictions

**DESIGNATION AND SALE OF ADDITIONAL TIMBER (Sec. 41.d.)**

This contract contains provisions for the sale and removal of additional timber necessary to facilitate safe and efficient purchaser operations. These provisions include:

- The designation and sale of additional timber, such as corridor and guylines trees, at contract price, as necessary to facilitate safe and efficient logging. Such trees may be felled and removed when they are painted by the Authorized Officer;
- Sale of additional timber volume at current fair market value where the species and/or size of trees are not representative of the forest stand(s) being thinned;
- Government reservation of trees previously marked for cutting (replacement) when the Authorized Officer determines that it is necessary in order to maintain stand densities consistent with objectives set forth in management prescriptions;
- The use of unilateral modifications executed by BLM for such additional timber and replacement timber;
- Revocation of the purchaser's right to cut additional timber if the Authorized Officer determines that trees have been cut and removed that were not previously marked and approved for cutting and removal by the Authorized Officer; and,
- It is estimated that approximately 675 MBF of such additional timber may be removed under the contract, but is not included in the advertised sale volume nor was it included in the timber sale appraisal

## Seasonal Restriction Matrix

\*Restricted Times are Shaded

Seasonal Restriction		Reason	Jan	Feb	Mar	Apr	May	Jun	Jul	Aug	Sep	Oct	Nov	Dec
9S-2E-sec. 13 All operation and hauling		Spotted Owl												
Falling and yarding		Bark slippage												
Hauling		Water quality and sedimentation, fish habitat												
Ground-based yarding		Soil damage/erosion control												
Skyline yarding		Soil damage/erosion control												
Road Construction / Decommissioning		Soil damage/erosion control												
In-water work: stream crossings/ culvert work		Protect fish and aquatic habitat												
Logging operations		Fire season, ODF closed fire season												
Key	Operations allowed.	Operations restricted, modified or allowed depending on conditions.					Operations restricted							



## TIMBER SALE CONTRACT SPECIAL PROVISIONS

### Sec. 40.

#### RESERVED

- a. All timber within the Reserve Area shown on Exhibit A and all painted orange or posted trees which are on or mark the boundaries of the Reserve Area and/or Rights-of-Way for Roads to be Constructed shown on Exhibit A.
- b. All trees marked with orange paint above and below stump height in the Partial Cut Area shown on Exhibit A.
- c. All snags fifteen (15) inches and larger DBH (diameter breast height) and taller than fifteen (15) feet in the Partial Cut Area shown on Exhibit A, except as otherwise provided in this contract.
- d. All existing down logs twenty (20) inches diameter and larger on the large end and at least twenty (20) feet long within the Partial Cut Area shown on Exhibit A, except as otherwise provided in this contract.
- e. All hardwood trees seven (7) inches and larger DBH in the Contract Area shown on Exhibit A, except as otherwise provided in this contract.

### Sec. 41. Special Provisions –

#### LOGGING

##### a. Periodic Payment and First Installment Adjustment

1. Notwithstanding the provisions of Sec. 3(b), the amount of the first installment may be reduced by the Government when the Contracting Officer requests the Purchaser to interrupt or delay operations for a period expected to last more than thirty (30) days during the operating season. Such interruption or delay must be beyond the Purchaser's control. Operating Season shall be defined, for this purpose, as the time of year in which operations of the type required are normally conducted and not specifically restricted under the contract. The first installment may be reduced to five (5) percent of the installment amount listed in Sec. 3 (b), during the delay period. The Purchaser must request such a reduction in writing. When the Contracting Officer notifies the Purchaser that operations may proceed, the Purchaser shall have fifteen (15) days after such notification to return the first installment to the full value specified in Sec. 3(b). Failure to return the first installment to the full value within the allotted time will be considered a material breach of contract. No timber shall be cut or removed from the Contract Area until the first installment is restored to the full amount.

2. Notwithstanding the provisions of Sec. 3(b), adjustments in the due dates for periodic payments may be made by the Government if the Contracting Officer interrupts or delays contract operations for a period expected to last at least thirty (30) days and the interruption or delay is beyond the Purchaser's control. Any adjustment made shall provide the Purchaser with an equal amount of operating time as would have been available without the delay. The Purchaser shall request such adjustment in writing before the due date for a periodic payment contained in Sec. 3(b).

b. Prior to the commencement of operations, the Purchaser shall obtain from the Authorized Officer written approval of a written operations and logging plan commensurate with the terms and conditions of the contract which shall include measures needed to assure protection of the environment and watershed. A prework conference between the Purchaser's authorized representative and the Authorized Officer's representative must be held at a location designated by the Authorized Officer before the logging plan will be approved. The Purchaser shall provide a minimum of seven (7) days' notice when requesting the scheduling of a prework conference.

c. Before beginning operations on the Contract Area for the first time or after a shutdown of fourteen (14) or more days, the Purchaser shall notify the Authorized Officer in writing of the date the Purchaser plans to begin operations. This written notification must be received by the Authorized Officer no less than seven (7) days prior to the date the Purchaser plans to begin or resume operations. The Purchaser shall also notify the Authorized Officer in writing if the Purchaser intends to cease operations for any period of seven (7) or more days.

d. Before cutting and removing any trees necessary to facilitate logging in the Partial Cut Area shown on Exhibit A, the Purchaser shall identify the locations of skid trails; skyline corridors; tailhold, tieback, guyline, lift, intermediate support and danger trees; and the clearing limits of landings on the ground in a manner approved by the Authorized Officer at the pre-work conference and documented in the logging plan required in Sec. 41.b. Said Purchaser identification of trees to be cut and removed does not constitute authority to proceed with cutting and removal. In addition, before proceeding the following conditions must be met:

1. All skid trails and skyline corridors upon which timber is identified by the Purchaser to be cut and removed in accordance with this special provision must be necessary for the safe and expeditious removal of timber sold under this contract and shall be limited to the minimum width necessary for yarding of logs with a minimum of damage to reserve trees, however, unless otherwise approved in writing by the Authorized Officer, the width of each skid trail and/or skyline corridor shall be limited to twelve (12) feet.

2. The Purchaser may immediately cut and remove additional timber to clear skid trails, skyline corridors and landings and cut danger trees when the trees have been marked with a paint color to be designated by the Authorized Officer above and below stump height by the Authorized Officer and thereby approved for cutting and removal by the Authorized Officer. The volume of the timber to be sold will be determined by the Authorized Officer in accordance with Bureau of Land Management prescribed procedures. No timber may be cut or removed under terms of this provision unless sufficient installment payments have been made in accordance with Sec. 3.(b) of the contract or sufficient bonding has been provided in accordance with Sec. 3.(d) of the contract.

3. The Purchaser agrees that sale of this additional timber shall be accomplished by a unilateral modification of the contract executed by the Contracting Officer and that such timber shall be sold at the unit prices shown in Exhibit B of this contract unless: the value of the timber must be reappraised subject to the terms for contract extension set forth in Sec. 9 of the contract; or, the Authorized Officer determines that the trees otherwise reserved in Sec. 40 of the contract or any tree that exceeds twenty-nine (29) inches diameter at breast height shall be appraised and sold by bilateral modification of the contract at current fair market value in accordance with Sec. 8 of the contract.

4. This authorization for the Purchaser to cut and remove additional timber prior to the execution of a modification may be withdrawn by the Contracting Officer if the Authorized Officer determines that the Purchaser has cut and removed any tree not previously marked and approved for cutting by the Authorized Officer, which under Sec. 10 of the contract constitutes a violation of the contract and under Sec. 13 of the contract may constitute a trespass rendering the Purchaser liable for damages under applicable law.

5. If authorization is withdrawn, the Contracting Officer shall issue a written notice to the Purchaser that the sale of additional timber under this special provision is no longer approved. In this case, the Purchaser shall inform the Authorized Officer at least one (1) working day prior to the need for cutting and removing any additional timber and execute a bilateral modification prior to cutting for such additional approved timber at the unit prices shown in Exhibit B of the contract or in accordance with Sec. 8 or Sec. 9 of the contract as determined by the Authorized Officer in accordance with this provision. The Contracting Officer may issue a written order to the Purchaser to suspend, delay or interrupt any or all contract work for the period of time deemed necessary and appropriate for the Government to safely measure and mark additional timber.

e. All hazardous trees and snags located in the Contract Area shown on Exhibit A that must be felled to comply with Sec. 15, Fire Prevention and Slash Disposal and Sec. 28, Safety and Health of this contract shall be felled by the Purchaser.

f. No trees may be felled across or into the Reserve Area shown on Exhibit A or adjacent private land unless expressly authorized by other provisions of this contract. Tops, limbs, and other logging debris entering the Reserve Area or adjacent private land from felling operations shall be pulled back into the Partial Cut Area shown on Exhibit A, unless otherwise directed by the Authorized Officer.

g. In the Partial Cut Area shown on Exhibit A, all trees designated for cutting and removal shall be felled and cut into log lengths not to exceed forty-two (42) feet before being yarded unless otherwise approved in writing by the Authorized Officer.

h. In the Partial Cut Area and Right-of-Way Area shown on Exhibit A, hardwood trees seven (7) inches and larger DBH, and snags fifteen (15) inches and larger DBH may be cut to facilitate logging operations, but not removed, when the trees have been marked with a paint color to be designated by the Authorized Officer above and below stump height by the Authorized Officer and thereby approved for cutting without removal. The felled tree shall be left in place unless otherwise approved by the Authorized Officer.

i. Existing down logs twenty (20) inches diameter and larger on the large end and at least twenty (20) feet long within the Partial Cut Area shown on Exhibit A and trees and snags felled as authorized in Sec. 41.e. and Sec.41.h., shall not be bucked into lengths less than twenty (20) feet or moved more than is necessary to facilitate logging unless otherwise approved by the Authorized Officer. Merchantable logs bucked from these down logs and felled trees shall be cut on a forty-five (45) degree angle to the axis of the tree.

j. In the Partial Cut Area – Ground-Based Yarding, shown on Exhibit A, skidding shall be done by a skidder equipped with a winch capable of winching logs seventy-five (75) feet unless otherwise agreed by the Authorized Officer. The minimum distance between skid trails shall be one hundred fifty (150) feet unless otherwise approved by the Authorized Officer. Such skid trails shall be limited to the minimum width necessary for skidding of logs with minimum damage to reserve trees. All trees that must be removed to facilitate construction of these skid trails shall be felled and skidded prior to falling operations in the remainder of these areas unless otherwise agreed by the Authorized Officer. The Purchaser shall directionally fall trees into lead with the winching or skidding direction and winch to these skid trails. The leading end of all logs shall be transported free of the ground during skidding. No skidding equipment shall be permitted to operate off these skid trails.

k. In the Partial Cut Area – Skyline Yarding, shown on Exhibit A, logs shall be yarded with the leading end of all logs transported free of the ground during in-haul yarding. The rigging of tail or lift trees or the use of tailholds outside the Partial Cut Area shown on Exhibit A shall be required where necessary to meet this requirement. Lift trees and skyline corridors shall be selected and flagged by the Purchaser and approved by the Authorized Officer prior to commencement of falling operations.

l. The following seasonal restrictions shall be observed:

1) No falling, ground based skidding, yarding, road construction or road decommissioning operations shall be conducted in Sec.13, T.9 S, R.2 E, from March 1 to July 15 of each year, both days inclusive, during Northern Spotted Owl nesting season unless waived in writing by the Authorized Officer.

2) No falling or yarding operations shall be conducted within the Contract Area as shown on Exhibit A from May 1 to June 30 of each year both days inclusive due to bark slippage, unless waived in writing by the Authorized Officer.

3) No hauling shall be conducted on the Contract Area shown on Exhibit A between November 1 of one calendar year and May 31 of the following year, both days inclusive.

4) No skidding or cable yarding shall be conducted on the Contract Area shown on Exhibit A between December 1 of one calendar year and May 31 of the following year both days inclusive unless individually waived annually by the Authorized Officer or during other periods of wet soil conditions as determined by the Authorized Officer.

5) No machine piling, road construction, renovation or road stabilization shall be conducted on the Contract Area shown on Exhibit A between November 1 of one calendar year and April 30 of the following year both days inclusive unless individually waived annually by the Authorized Officer or during other periods of wet soil conditions as determined by the Authorized Officer.

6) No in-stream work shall be conducted on the Contract Area shown on Exhibit A between October 16 of one calendar year and May 31 of the following year, both days inclusive to protect water quality and aquatic habitat.

m. No winching, skidding or yarding is permitted across any stream shown on Exhibit A unless waived in writing by the Authorized Officer.

n. Prior to attaching any logging equipment to a reserve tree designated in Sec. 40., the Purchaser shall obtain written approval from the Authorized Officer and shall take precautions to protect the tree from damage as directed in writing by the Authorized Officer.

**ROAD CONSTRUCTION, IMPROVEMENT, RENOVATION, MAINTENANCE AND USE**

o. The Purchaser shall construct and renovate roads in strict accordance with the plans and specifications shown on Exhibit C, which is attached hereto and made a part hereof.

p. Any required construction or renovation of roads shall be completed and accepted prior to the removal of any timber, except right-of-way timber, over that road.

q. The Purchaser shall not commence work until receipt of written notice to do so from the Authorized Officer.

r. The Purchaser is authorized to use the roads listed below and shown on Exhibit C which are under the jurisdiction of the Bureau of Land Management, for the removal of Government timber sold under the terms of this contract provided that the Purchaser comply with the conditions set forth in Section 41.t. The Purchaser shall pay current Bureau of Land Management rockwear fees for the sale of additional timber under modification of the contract.

Road No. and Segment	Length Miles Used	Road Control	Road Surface Type
9-2E-12.1 C2 -D2	1.78	BLM	Aggregate
9-2E-12.2 D	0.36	BLM	Aggregate
9-2E-12.4 A-B	0.55	BLM	Aggregate
9-2E-13 A-B	0.27	BLM	Aggregate
9-2E-25.2 A	0.07	BLM	Aggregate
9-2E-25.3 B	0.05	BLM	Aggregate
9-3E-17.3	0.07	BLM	Natural
9-3E-19 B1	0.33	BLM	Aggregate
9-3E-19.1 B	0.19	BLM	Aggregate
9-3E-19.3	0.42	BLM	Natural
9-3E-20 A-B	0.22	BLM	Aggregate
9-3E-30 B -C1	0.38	BLM	Aggregate

s. The Purchaser shall also pay to the Government a road maintenance obligation for rockwear in the amount of one thousand seventy-seven and 30/100 dollars (\$1,077.30) for the transportation of timber included in the contract price over road or roads listed in Section 41.r. The amount of the rockwear shown above shall be paid prior to removal of timber from the contract area; provided, however, that if the total of such amount exceeds five hundred dollars (\$500.00), the Purchaser may elect to make the payment in installments in the same manner as and together with payments required in Section 3 of this contract.

t. The Purchaser shall perform any road repair and maintenance work on roads used by him, under the terms of Exhibit D, "Purchaser Road Maintenance Specifications," of this contract which is attached hereto and made a part hereof.

u. In the use of roads listed below and shown on Exhibit C, the Purchaser shall comply with the conditions of Right-of-Way and Road Use Agreement No. S-407 (OR047128) dated April 30, 1959 between the United States of America and Freres Timber, Inc. These conditions include: Payment to Freres Timber, Inc., a road use obligation of Nine thousand eight-hundred eighteen and 00/100 (\$9,818.00) and a road maintenance and rockwear obligation of Four thousand three-hundred sixty-three and 97/100 (\$4,363.97) payable at the time indicated in the license agreement. This document is available for inspection at the office of the Authorized Officer. Prior to the use of said roads, the Purchaser shall furnish the Authorized Officer a copy of the executed license agreement. Default by the Purchaser of said Right-of-Way and Road use Agreement or any license agreement executed pursuant thereto, for failure to pay appropriate road use fees shall be considered a violation of this contract. The amount of unpaid fees shall be considered as the amount of damage suffered by the Government as a result of the violation of this provision. The Purchaser will be required to carry liability insurance with limits of \$1,000,000/\$2,000,000/\$2,000,000 and a performance bond of \$5,000.

Road No. and Segment	Length Miles Used	Road Control	Road Surface Type
9-2E-1.6 A -B	0.20	Freres	Aggregate
9-2E-10 A - C	1.55	Freres	Aggregate
9-2E-11.1 A- C	0.74	Freres	Natural
9-2E-12 A-C	0.62	Freres	Aggregate
9-2E-12.2 A-B, E	0.77	Freres	Aggregate
9-2E-12.3 A1	0.24	Freres	Aggregate
9-3E-29 A, C, I-L	0.75	Freres	Aggregate

v. In the use of roads listed below and shown on Exhibit C, the Purchaser shall comply with the conditions of Right-of-Way and Road Use Agreement No. S-799C (OR045586) dated May 7, 1973 between the United States of America and Frank Timber Resources, Inc. These conditions include: Payment to Frank Timber Resources, Inc., a road use obligation of Five hundred twenty-seven and 16/100 (\$527.16) payable at the time indicated in the license agreement, maintain roads and in lieu of a rockwear obligation place 20 cy truck measure of surface rock on roads as directed by the Authorized Officer. This document is available for inspection at the office of the Authorized Officer. Prior to the use of said roads, the Purchaser shall furnish the Authorized Officer a copy of the executed license agreement. Default by the Purchaser of said Right-of-Way and Road Use Agreement or any license agreement executed pursuant thereto, for failure

to pay appropriate road use fees shall be considered a violation of this contract. The amount of unpaid fees shall be considered as the amount of damage suffered by the Government as a result of the violation of this provision. The Purchaser will be required to carry liability insurance with limits of \$1,000,000/\$1,000,000/\$1,000,000 and a performance bond of \$2,000.

Road No. and Segment	Length Miles Used	Road Control	Road Surface Type
9-3E-10 O-P	0.15	Frank	Aggregate
9-3E-19 A	0.87	Frank	Aggregate
9-3E-19.1 A1-A2	0.65	Frank	Aggregate
9-3E-29 E, F1, H	0.13	Frank	Aggregate

w. In the use of roads listed below and shown on Exhibit C, the Purchaser shall comply with the conditions of Right-of-Way and Road Use Agreement No. S-975 (OR045540) dated November 2, 1987 between the United States of America and Weyerhaeuser Company. These conditions include: Payment to Weyerhaeuser Company a road use obligation of Four hundred seventy and 00/100 (\$470.00) payable at the time indicated in the license agreement, maintain roads, and in lieu of a rockwear obligation place 10 cy truck measure surface rock on roads as directed by the Authorized Officer. This document is available for inspection at the office of the Authorized Officer. Prior to the use of said roads, the Purchaser shall furnish the Authorized Officer a copy of the executed license agreement. Default by the Purchaser of said Right-of-Way and Road Use Agreement or any license agreement executed pursuant thereto, for failure to pay appropriate road use fees shall be considered a violation of this contract. The amount of unpaid fees shall be considered as the amount of damage suffered by the Government as a result of the violation of this provision. The Purchaser will be required to carry liability insurance with limits of \$1,000,000/\$1,000,000/\$1,000,000 and a performance bond of \$1,000.

Road No. and Segment	Length Miles Used	Road Control	Road Surface Type
9-2E-25.3 A	0.06	Weyerhaeuser	Aggregate
9-3E-30 A, C2	0.45	Weyerhaeuser	Aggregate

x. In the use of road listed below and shown on Exhibit C, the Purchaser shall comply with the conditions of Access Road Easement RE S-1232 (OR066627) dated August 9, 2011 between the United States of America and Robert Ward and Alfred Ward. The condition for this easement is: maintain and repair the road, and leave it in as good a condition as prior to use.

Road No. and Segment	Length Miles Used	Road Control	Road Surface Type
9-3E-29 B, D, F2, G	0.17	Ward	Aggregate

y. In the renovation and use of the 9-3E-19.1 segment C as shown on Exhibit C, the Purchaser shall comply with the terms and conditions of the Cooperative Right-of-Way Agreement, State of Oregon and the United States, dated April 19, 1960, which requires that the Purchaser obtain and enter into a license agreement with the Oregon State Department of Forestry. Prior to commencement of operations, the Purchaser shall furnish to the Authorized Officer a copy of the required executed license agreement. These conditions include: maintain and repair the road, and leave it in as good condition as prior to use.

z. The Purchaser also agrees that if they elect to use any other private road which is the subject of a right-of-way agreement with the Government for the removal of Government timber sold under the terms of this contract, Purchaser shall request and agree to the modification of this contract to provide for such use and for allowances for amortization of the Government's share of the capital investment of any such road.

aa. In the construction of Roads P1, P8 and P10, as shown on Exhibit C, the Purchaser shall comply with the conditions of the Right-of-Way and Road Use Agreement No. S-407 dated April 30, 1959 between the United States and Freres Timber Inc. This document is available for inspection at the office of the Authorized Officer.

bb. In the construction of Road P5, as shown on Exhibit C, the Purchaser shall comply with the conditions of the Right-of-Way and Road Use Agreement No. S-799C dated May 7, 1973 between the United States and Frank Timber Resources. This document is available for inspection at the office of the Authorized Officer.

cc. The Purchaser shall be required to secure written approval to use vehicles or haul overweight equipment over Government-owned or controlled and/or private bridges/structures when such vehicles or equipment exceed the maximum allowable weights or dimensions established by the State for vehicles operating without a permit.

Tracked-type equipment shall not be allowed to cross over concrete-bridge decks, other concrete surfaced structures, or asphalt surfaced roads without the proper protection of that surface. Prior approval shall be obtained from the Authorized Officer when crossing with protective devices.

Details of such equipment shall be furnished to the Authorized Officer for evaluation of load characteristics at least fifteen (15) days prior to proposed move in.

Details shall include:

- A. Axle weights when fully loaded.
- B. Axle spacing.
- C. Transverse wheel spacing.
- D. Tire size.
- E. Outside width of vehicles.
- F. Operating speed.
- G. Frequency of use.
- H. Special features (e.g., running tracks, overhang loads, etc.).

The Purchaser shall be responsible for repair of any damage to roads or structures caused by the use of overweight or overdimension or tracked vehicles or equipment: (1) without written approval, or (2) in



violation of the conditions of a written approval, or (3) in a negligent manner. The amount of actual damage shall be determined by the Authorized Officer following technical inspection and evaluation.

### ENVIRONMENTAL PROTECTION

dd. In addition to the requirements set forth in Sec. 25 of this contract, the Purchaser shall clean all plant parts and soil from all earth disturbing equipment prior to entry onto and departure from lands managed by the BLM unless otherwise agreed by the Authorized Officer to reduce or prevent the spread of noxious weeds to and from the Contract Area shown on Exhibit A. Equipment shall be inspected by the Authorized Officer at a site approved by the Authorized Officer to verify that the equipment had been reasonably cleaned prior to entry onto lands managed by the BLM.

ee. In addition to the requirements set forth in Sec. 25 of this contract, the Purchaser shall cover skid trails with logging slash and debris and block entrances or other created access points on the Contract Area shown on Exhibit A as directed by the Authorized Officer.

ff. If in connection with operations under this contract the Purchaser, his contractors, subcontractors or the employees of any of them, discover, encounter or become aware of any objects or sites of cultural value on the contract area such as historical or prehistorical ruins, graves or grave markers, fossils or artifacts, the Purchaser shall immediately suspend all operations in the vicinity of the cultural value and notify the Authorized Officer of the findings. Operations may resume at the discovery site upon receipt of written instructions and authorization by the Authorized Officer.

gg. The Purchaser shall immediately discontinue specified construction or timber harvesting operations upon written notice from the Contracting Officer that:

- (1) threatened or endangered plants or animals protected under the Endangered Species Act of 1973, as amended, may be affected by the operation, and a determination is made that consultation or reinitiation of consultation is required concerning the species prior to continuing operation, or;
- (2) when, in order to comply with the Endangered Species Act the Contracting Officer determines it may be necessary to modify or terminate the contract, or;
- (3) federal proposed, federal candidate, Bureau sensitive or State listed species protected under BLM Manual 6840 - Special Status Species Management - have been identified, and a determination is made that continued operations would affect the species or its habitat, or;
- (4) other active raptor nests have been discovered, and a determination is made that continued operations under this contract would adversely affect the present use of the discovered nesting area by the raptor, or;
- (5) when, in order to comply with a court order which enjoins operations on the sale or otherwise requires the Bureau of Land Management to suspend operations, or;

- (6) when, in order to comply with a court order, the Contracting Officer determines it may be necessary to modify or terminate the contract, or;
- (7) species have been discovered which were identified for protection through survey and manage and/or protection buffer standards and guidelines established in the ROD and RMP, and the Contracting Officer determines that continued operations would affect the species or its habitat, or;
- (8) when, in order to protect species which were identified for protection through survey and manage and/or protection buffer standards and guidelines established in the ROD and RMP, the Contracting Officer determines it may be necessary to modify or terminate the contract.

Those operations necessary for a safe removal of personnel and equipment from the contract area and those directed by the Contracting Officer which are required in order to leave the contract area in an acceptable condition will be permitted. Discontinued operations may be resumed upon receipt of written instructions and authorization by the Contracting Officer.

During any period of suspension, the Purchaser may withdraw performance and payment bond coverage aside from that deemed necessary by the Authorized Officer to secure cut and/or removed timber for which the Bureau of Land Management has not received payment, and/or unfulfilled contract requirements associated with harvest operations that have already occurred and associated post-harvest requirements.

In the event of a suspension period or a combination of suspension periods that exceed a total of 30 days, the First Installment held on deposit may be temporarily reduced upon the written request of the Purchaser. For the period of suspension extending beyond 30 days, the First Installment on deposit may be reduced to five (5) percent of the First Installment amount listed in Section 3.b. of the contract. Any First Installment amount temporarily reduced may be refunded or transferred to another BLM contract at the request of the Purchaser. However, if the Purchaser has outstanding debt owing the United States, the Contracting Officer must first apply the amount of First Installment that could be refunded to the debt owed in accordance with the Debt Collection Improvement Act, as amended (31 USC 3710, *et seq.*). Upon Purchaser's receipt of a bill for collection and written notice from the Contracting Officer lifting the suspension, the Purchaser shall restore the First Installment to the full amount shown in Section 3.b. of the contract within 15 days after the bill for collection is issued, subject to Section 3.h. of the contract. The Purchaser shall not resume contract operations until the First Installment amount is fully restored.

In the event of a suspension period or a combination of suspension periods that exceed a total of 30 days, the unamortized Out-of-Pocket Expenses for road or other construction required pursuant to Exhibit C of the contract shall be refunded or transferred to another BLM contract at the request of the Purchaser. Upon written notice from the Contracting Officer lifting the suspension, the Purchaser shall reimburse the Government the amounts refunded or transferred. The Purchaser may choose to pay this reimbursement at once or in installments payable at the same time as payments are due for the timber under the contract and in amounts approximately equal to the expenses associated with the timber for which payment is due.

In the event that operating time is lost as a result of the incorporation of additional contract requirements, or delays due to Endangered Species Act consultation with the U.S. Fish and Wildlife Service or U.S. National Marine Fisheries Service, or court-ordered injunctions, the Purchaser agrees that an extension of time, without reappraisal, will constitute a full and complete remedy for any claim that delays due to the suspension hindered performance of the contract or resulted in damages of any kind to the Purchaser.

The Contracting Officer may determine that it is necessary to terminate the cutting and removal rights under the contract in order to comply with the Endangered Species Act, protect species that have been discovered which were identified for protection through survey and manage and/or protection buffer standards and guidelines established in the ROD and RMP, or comply with a court order. Following the issuance of a written notice that cutting and removal rights will be terminated, the Purchaser will be permitted to remove timber cut under the contract, if allowed by the Endangered Species Act, survey and manage and/or protection buffer standards and guidelines established in the ROD and RMP, or court order requirements necessitating the modification or termination.

In the event cutting and removal rights are terminated under this subsection, the Purchaser agrees that the liability of the United States shall be limited to the actual costs incurred by the Purchaser which have not been amortized by timber removed from the contract area. This calculation of liability shall utilize actual Purchaser costs and Government estimates of timber volumes. At the Authorized Officer's request, the Purchaser agrees to provide documentation of the actual costs incurred in the performance of the contract. In addition, the Purchaser shall be released from the obligation to pay the contract price for any timber which is not authorized to be removed from the contract area.

The Purchaser specifically and expressly waives any right to claim damages, other than those described in the preceding paragraphs, based on an alleged breach of any duty to the Purchaser, whether express or implied, in regard to the manner in which the Government defended the litigation which resulted in the court order affecting the operation of the contract. This waiver also extends to any claims based on effects on the operation of the contract that arise from litigation against another agency. Furthermore, the Purchaser specifically acknowledges and agrees that a court ruling that the Government violated the Administrative Procedures Act cannot be interpreted, in itself, to mean that the Government had not acted reasonably in regard to its duties to the Purchaser under this contract.

### FIRE PROTECTION

hh. Primarily for purposes of fire prevention and control, the Purchaser shall comply with the following provisions when operating at Oregon Department of Forestry (ODF) Industrial Fire Precaution Level (IFPL) I (Closed Fire Season). At IFPL II and III, additional fire prevention and control provisions may be added as determined by the Authorized Officer and specified in written instructions to the Purchaser to mitigate dry fuel and weather conditions:

1. Prior to the operation of power driven equipment in construction or logging operations under this contract during the closed fire season or periods of fire danger, prepare a fire prevention and control plan to the satisfaction of the Authorized Officer.

2. Provide and maintain in good working order, and immediately available on the Contract Area shown on Exhibit A, the following equipment for use during closed fire season or periods of fire danger:

(a) Firefighting tools shall be kept at each landing or at such other place as the Authorized Officer shall designate whenever people are working on the contract area. All firefighting tools shall be kept in a sturdily constructed box which shall be painted red and lettered on the front or top in large letters "For Fire Only." The box shall have a hinged lid and a hasp by which the lid can be sealed. One (1) box may serve two landings, not over six hundred (600) feet apart. When filled, the box shall not weigh over two hundred (200) pounds. The fire tools shall be in good condition, be tight on strong handles, and have sharp cutting edges. There shall be not less than four (4) tools in each box or less than one (1) tool for each person working on the contract area. Three-fourths (3/4) of all fire tools shall be shovels, hazel hoes, or other scraping tools. The fire tools shall be used only for fighting fire.

(b) At each landing or such other place as the Authorized Officer shall designate during periods of operation, one fire engine/tank truck of one thousand (1,000) gallons or more capacity with five hundred (500) feet of 1 ½ inch hose, five hundred (500) feet of 1 inch hose, one (1)-1½ inch gated wye, one (1) - 1 inch gated wye, two (2) - 1½ to 1 inch reducer adapters and three (3) - 1 inch nozzles. The fire engine/tank truck shall be equipped with a pump capable of delivering a minimum of forty (40) gallons per minute (gpm) water flow at one hundred fifty (150) pounds per square inch (psi) engine pressure through fifty (50) feet of 1½ inch fire hose. The pump may be either PTO driven or truck mounted auxiliary engine driven. All equipment shall be acceptable to and approved by the Authorized Officer and shall conform to the standards set forth in Oregon Revised Statutes 477.645 through 477.670 and any rule promulgated pursuant to these statutes. All hose couplings shall have the standard thread adopted by the BLM (1½ inch National Hose Thread (NH), 1 inch National Pipe Straight Hose Thread (NPSH)) or be provided with suitable adapters. At the close of each working day, all fire engines/tank trucks shall be filled with water and made available for immediate use. This includes the keys or similar starting device to the fire engine/tank truck.

(c) Two (2) backpack pumps at each landing and one (1) at each tail block, or any other block, all to be kept full of water and in good operating condition.

(d) A chemical fire extinguisher of at least eight (8) ounces minimum capacity of a type approved by the Oregon State Forester and a size 0 or larger shovel shall be carried during the closed fire season or periods of fire danger by each falling crew and each buckler using a power saw on the Contract Area shown on Exhibit A. Such fire extinguisher shall be filled and in effective operating condition and shall at all times be immediately available to the operator when the saw is being fueled or the motor of the saw is running. Any fueling of a power saw shall be done in an area which has first been cleared of all flammable material. Power saws shall be moved at least twenty (20) feet from the place of fueling before the engine is started. Each power saw shall be equipped with an exhaust system and a spark arresting device which are of types approved by the Oregon State Forester.

3. During Oregon Department of Forestry (ODF) Closed Fire Season no smoking shall be permitted outside of closed vehicles.

## LOGGING RESIDUE REDUCTION

ii. Within thirty (30) feet of the edge of each landing, all tops, broken pieces, limbs and debris more than one (1) inch in diameter at the large end and longer than three (3) feet in length shall be piled within fifteen (15) days of completion of hauling logs from that landing. Landing piles shall be kept free of dirt and located adjacent to roads at least twenty (20) feet from any reserve tree and/or as directed by the Authorized Officer. Upon completion of landing piling, the Purchaser shall prepare the landing piles for burning by securely covering each landing pile by securely covering each pile with polyethylene plastic film a minimum of .004 inch thick. Landing piles shall be covered with enough plastic to keep pile dry enough to ensure pile consumption. Woody debris shall then be placed on top of the plastic so that both sides and the middle are held in place during strong wind conditions. The Purchaser is required to furnish the covering materials. The timing of this covering work shall be in accordance with instructions from the Authorized Officer. If, in the opinion of the Authorized Officer, the structure of the landing piles will not permit adequate consumption of piled debris by burning, the Purchaser shall re-pile them at the direction of the Authorized Officer.

jj. In the LD Areas shown on Exhibit F, which is attached hereto and made a part hereof, all slash and debris created by Purchaser's operations shall be machine piled and covered in accordance with Exhibit G which is attached hereto and made a part hereof. The required work shall consist of up to six (6) acres of machine piling logging slash and covering the piles. Piling and covering operations shall be completed within thirty (30) days after completion of skidding or yarding on the LD Areas in each Unit shown on Exhibit F, or as directed by the Authorized Officer. In the Slash pull back areas as shown on Exhibit F, all slash and debris created by Purchaser's operations shall be removed at least 50 feet from the from the edges of designated property lines. All work shall be done as directed by the Authorized Officer in accordance with the specifications described on Exhibit G.

kk. Notwithstanding the provisions of Sec. 15 of this contract, the Government shall assume all obligations for the disposal or reduction of the fire hazards caused by slash created by the Purchaser's operations on Government lands, except for logging residue reduction operations and except for the burning, fire control and patrol assistance of landing piles as required herein. In accordance with written instructions to be issued by the Authorized Officer at least ten (10) days in advance of earliest date of required performance, the Purchaser shall, under supervision of the Authorized Officer or his designated representative, assist in the burning, fire control and patrol assistance of landing piles by furnishing, at his own expense, the services of personnel and equipment on each Unit Area shown on Exhibit A as specified below:

1. One (1) work leader (Firefighter Type 1 (FFT1) qualified according to National Wildfire Coordinating Group (NWCG) Wildland Fire Qualification System Guide, PMS 310-1) to supervise crew and equipment operators and to serve as Purchaser's representative.
2. Three (3) person crew (Firefighter Type 2 (FFT2) qualified according to National Wildfire Coordinating Group (NWCG) Wildland Fire Qualification System Guide, PMS 310-1) for burning preparation, ignition and holding and mop-up operations with hand tools on the day of ignition.
3. Four (4) drip torches with forty (40) gallons of slash fuel (4:1 ratio of diesel to gasoline).
4. One (1) fire engine of four hundred (400) gallon capacity. The engine shall comply with all Oregon State Department of Motor Vehicle regulations, be filled with water and equipped with an operator and the following:

subsection, liability shall be borne by the Purchaser, unless such injury or damage is caused by Government negligence.

9. Time is of the essence in complying with this provision. In the event the Purchaser fails to provide the personnel and equipment required herein, the Purchaser shall be responsible for all additional cost incurred by the Government in disposing of slash including but not limited to the wages and other costs of providing federal employees and others as substitute labor force, the cost of providing substitute equipment and appropriate additional overhead expenses. If the Purchaser's failure results in a deferral of burning and new conditions necessitate additional site preparation work and/or the use of additional personnel and equipment to accomplish the planned burn, the Purchaser also shall be responsible for such additional costs.

### CONTRIBUTED FUNDS

11. The Purchaser shall assist the Government in burning piles in accordance with Sec. 41.kk. The Purchaser shall have the option of completing this work, or in lieu of pile burning operations only, may make a contribution to the Bureau of Land Management in the amount of One thousand, nine hundred fifty and 05/100 dollars (\$1,950.05). Upon making such contribution, the Purchaser shall be relieved of the pile burning obligations set out in Sec. 41.11. The Purchaser shall notify the Authorized Officer in writing of the Purchaser's intention to make this contribution prior to approval of this contract. If the Purchaser elects to make a contribution, the Authorized Officer shall establish an installment schedule of payments of the contribution.

### LOG EXPORT RESTRICTIONS

mm. All timber sold to the Purchaser under the terms of the contract, except exempted species, is restricted from export under the United States in the form of unprocessed timber and is prohibited from being used as a substitute for exported private timber. For the purpose of this contract, unprocessed timber is defined as: (1) any logs, except those of utility grade or below, such as sawlogs, peeler logs and pulp logs; (2) cants or squares to be subsequently remanufactured exceeding eight and three-quarters (8-3/4) inches in thickness; (3) split or round bolts or other roundwood not processed to standards or specifications or suitable for end-product uses; or (4) western red cedar lumber which does not meet lumber of American Standards Grades of Number 3 dimension or better, or Pacific Lumber Inspection Bureau R-List Grades of Number 3 Common or better. Thus, timber manufactured into the following will be considered processed: (1) lumber and construction timbers regardless of size, manufactured to standards and specifications suitable for end-product uses; (2) chips, pulp, and pulp products; (3) green or dry veneer and plywood; (4) poles and piling cut or treated for use as such; (5) cants, squares, and lumber cut for remanufacturing of eight and three-quarters (8-3/4) inches in thickness or less; (6) shakes and shingles.

Substitution will be determined under the definition found in 43 CFR 5400.0-5(n).

The Purchaser is required to maintain and upon request to furnish the following information:

1. Date of last export sale.
2. Volume of timber contained in last export sale.
3. Volume of timber exported in the past twelve (12) months from the date of last export sale.

4. Volume of Federal timber purchased in the past twelve (12) months from the date of last export sale.
5. Volume of timber exported in succeeding twelve (12) months from date of last export sale.
6. Volume of Federal timber purchased in succeeding twelve (12) months from date of last export sale.

In the event the Purchaser elects to sell any or all of the timber sold under this contract in the form of unprocessed timber, the Purchaser shall require each party buying, exchanging or receiving such timber to execute a "Certificate as to Nonsubstitution and the Domestic Processing of Timber". The original of such certification shall be filed with the Authorized Officer. Additionally, when the other party is an affiliate of the Purchaser, the Purchaser will be required to update information under item (2) of Form 5450-17 (Export Determination) and file the form with the Authorized Officer.

In the event an affiliate of the Purchaser has exported private timber within twelve (12) months prior to purchaser or otherwise acquiring Federal timber sold under this contract, the Purchaser shall, upon request, obtain from the affiliate information in the form specified by the Authorized Officer and furnish the information to the Authorized Officer.

Prior to the termination of this contract, the Purchaser shall submit to the Authorized Officer Form 5460-15 (Log Scale and Disposition of Timber Removed Report) which shall be executed by the Purchaser. In addition, the Purchaser is required under the terms of this contract, to retain for a three-year period from the date of termination of the contract the records of all sales or transfer of logs involving timber from the sale for inspection and use of the Bureau of Land Management.

Unless otherwise authorized in writing by the Contracting Officer, the Purchaser shall brand clearly and legibly one end of all logs with a scaling diameter (small end inside bark) of over ten (10) inches, prior to the removal of timber from the contract area. All loads of eleven (11) logs or more will have a minimum of ten (10) logs clearly and legibly branded on one end regardless of the diameter of the logs. All logs will be branded on loads of ten (10) logs or less. One end of all branded logs to be processed domestically will be marked with a three (3) square inch spot of highway yellow paint. The Purchaser will stop trucks for accountability monitoring at mutually agreed upon locations when notified by the Authorized Officer.

If multiple trailers (mule trains) are used, each bunked load shall be considered an individual load and these guidelines will apply to each bunked load. If a flatbed stake trailer is used, each bundle will be treated as a separate load.

At the discretion of the Contracting Officer, the Purchaser may be required to brand and paint all logs. Any increased cost for log branding and painting shall be the responsibility of the Purchaser.

In the event of the Purchaser's noncompliance with this subsection of the contract, the Authorized Officer may take appropriate action as set forth in Sec. 10 of this contract. In addition, the Purchaser may be declared ineligible to receive future awards of Government timber for a period of one year.

#### EQUAL OPPORTUNITY IN EMPLOYMENT

nn. Certification of Nonsegregated Facilities, Form 1140-3, is attached hereto and made a part hereof.

UNITED STATES  
DEPARTMENT OF THE INTERIOR  
BUREAU OF LAND MANAGEMENT

Bid, offer, or contract number  
or other identification

ORS000-TS12-502

EQUAL OPPORTUNITY IN EMPLOYMENT  
CERTIFICATION OF NONSEGREGATED FACILITIES

By the submission of this bid or offer and/or by entering into this contract, the bidder, offeror, lessee, subcontractor, or applicant certifies that he does not maintain or provide for his employees any segregated facilities at any of his establishments, and that he does not permit his employees to perform their services at any location, under his control, where segregated facilities are maintained. He certifies further that he will not maintain or provide for his employees any segregated facilities at any of his establishments, and that he will not permit his employees to perform their services at any location, under his control, where segregated facilities are maintained. The bidder, offeror, applicant, or subcontractor agrees that a breach of this certification is a violation of the Equal Opportunity clause in this contract. As used in this certification, the term "segregated facilities" means, but is not limited to, any waiting rooms, work areas, rest rooms and wash rooms, restaurants and other eating areas,

time clocks, locker rooms and other storage or dressing areas, parking lots, drinking fountains, recreation or entertainment areas, transportation, and housing facilities provided for employees which are segregated by explicit directive or are in fact segregated on the basis of race, color, religion, sex, or national origin, because of habit, local custom, or otherwise. He further agrees that (except where he has obtained identical certifications from proposed subcontractors for specific time periods) he will obtain identical certifications from proposed subcontractors prior to the award of subcontractors exceeding \$10,000 which are not exempt from the provisions of the Equal Opportunity clause; that he will retain such certifications in his files; and that he will forward the following notice to such proposed subcontractors (except where the proposed sub-contractors have submitted identical certifications for specific time periods):

NOTICE TO PROSPECTIVE SUBCONTRACTORS OF REQUIREMENT  
FOR CERTIFICATIONS OF NONSEGREGATED FACILITIES

A Certification of Nonsegregated Facilities, as required by the May 9, 1967, order (32 F.R. 7439, May 19, 1967) on Elimination of Segregated Facilities, by the Secretary of Labor, must be submitted prior to the award of a sub- contract exceeding \$10,000 which is

not exempt from the provisions of the Equal Opportunity clause. The certification may be submitted either for each subcontract or for all subcontracts during a period (i.e., quarterly, semiannually, or annually).

In accordance with 41 CFR 60, as amended May 19, 1967, and Executive Order No. 11246 of September 24, 1965, as amended, this certification is applicable to all bids, offers, contracts and subcontracts as well as agreements with applicants who are themselves performing federally assisted contracts, which may exceed \$10,000 and are not exempt from the provisions of the Equal Opportunity clause of the Order.



United States Department of the Interior  
 BUREAU OF LAND MANAGEMENT  
 Salem District - Oregon  
**TIMBER SALE CONTRACT MAP - Contract No. ORS040-TS12-502**  
 T.9S., R2E., sections 11,13 & 25 & T.9S., R.3E., Sections 17, 19 & 21 W. M.

Power Mill Thinning  
 Timber Sale  
 Exhibit A  
 Page 1 of 6

May 15, 2012

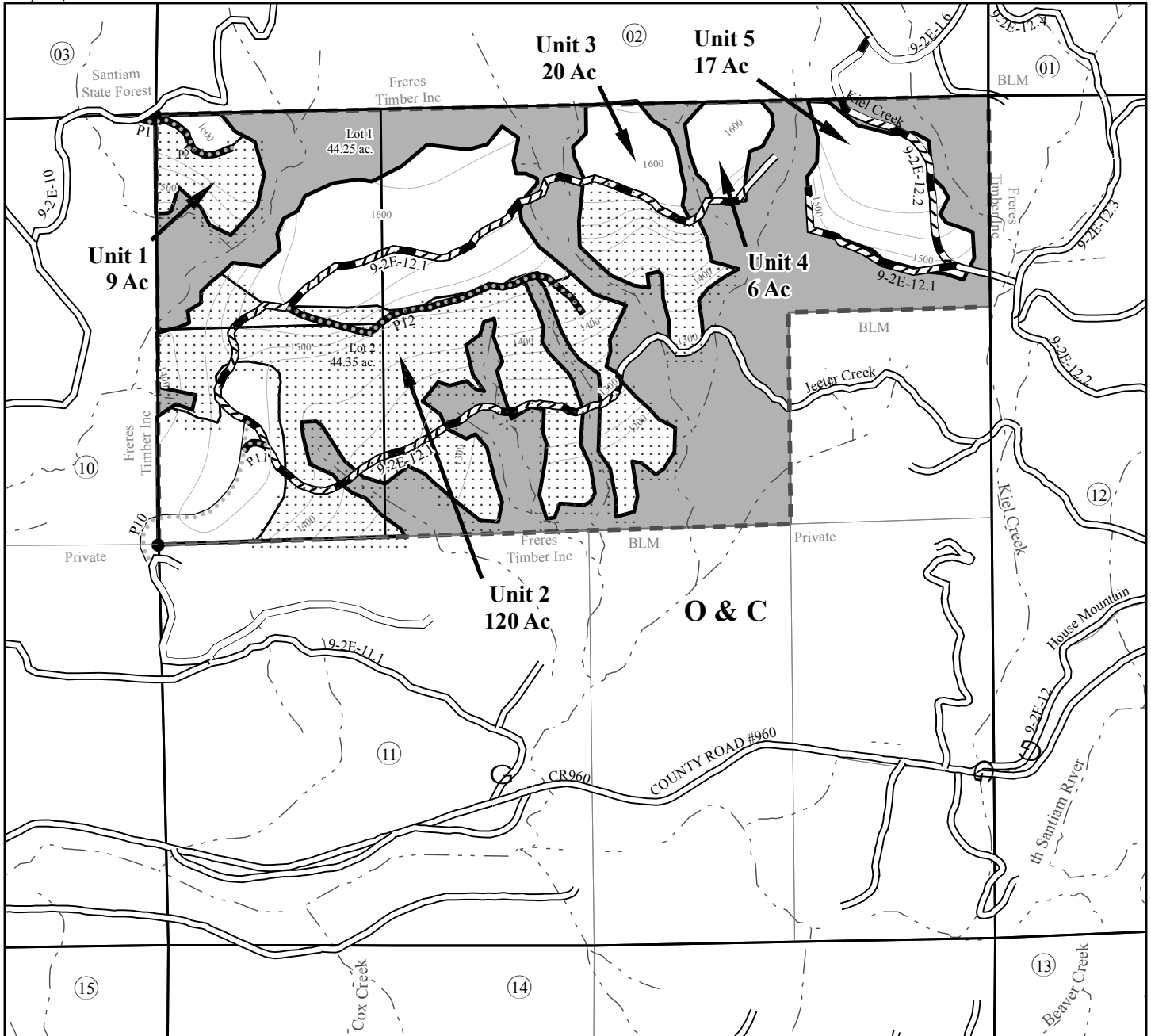

1,000 500 0 Feet



- Corner Found
- Existing Road
- == Highway
- - Stream
- Right-of-Way  
 Road to be Constructed
- Right-of-Way  
 Road to be Renovated

- G Gate
- Contract Area
- Reserve Area
- Partial Cut Area Unit Boundary
- Partial Cut Area - Skyline Yarding
- Partial Cut Area - Ground-Based Yarding

Partial Cut Area	354 Acres
Road Right of Way	8 Acres
Reserve Area	323.75 Acres
<b>Contract Area</b>	<b>691.75 Acres</b>

Contour Interval : 20'



Note: Boundaries of Partial Cut Area are painted orange and posted.

Note: Unit acres do not include existing or new roads. Acres shown on Exhibit A have been computed using a Trimble Geo XT global positioning system receiver. Acreage was calculated based on global positioning system traverse procedures including differential correction.

United States Department of the Interior  
 BUREAU OF LAND MANAGEMENT  
 Salem District - Oregon  
**TIMBER SALE CONTRACT MAP - Contract No. ORS040-TS12-502**  
 T.9S., R2E., sections 11,13 & 25 & T.9S., R.3E., Sections 17, 19 & 21 W. M.

Power Mill Thinning  
 Timber Sale  
 Exhibit A  
 Page 2 of 6

May 15, 2012

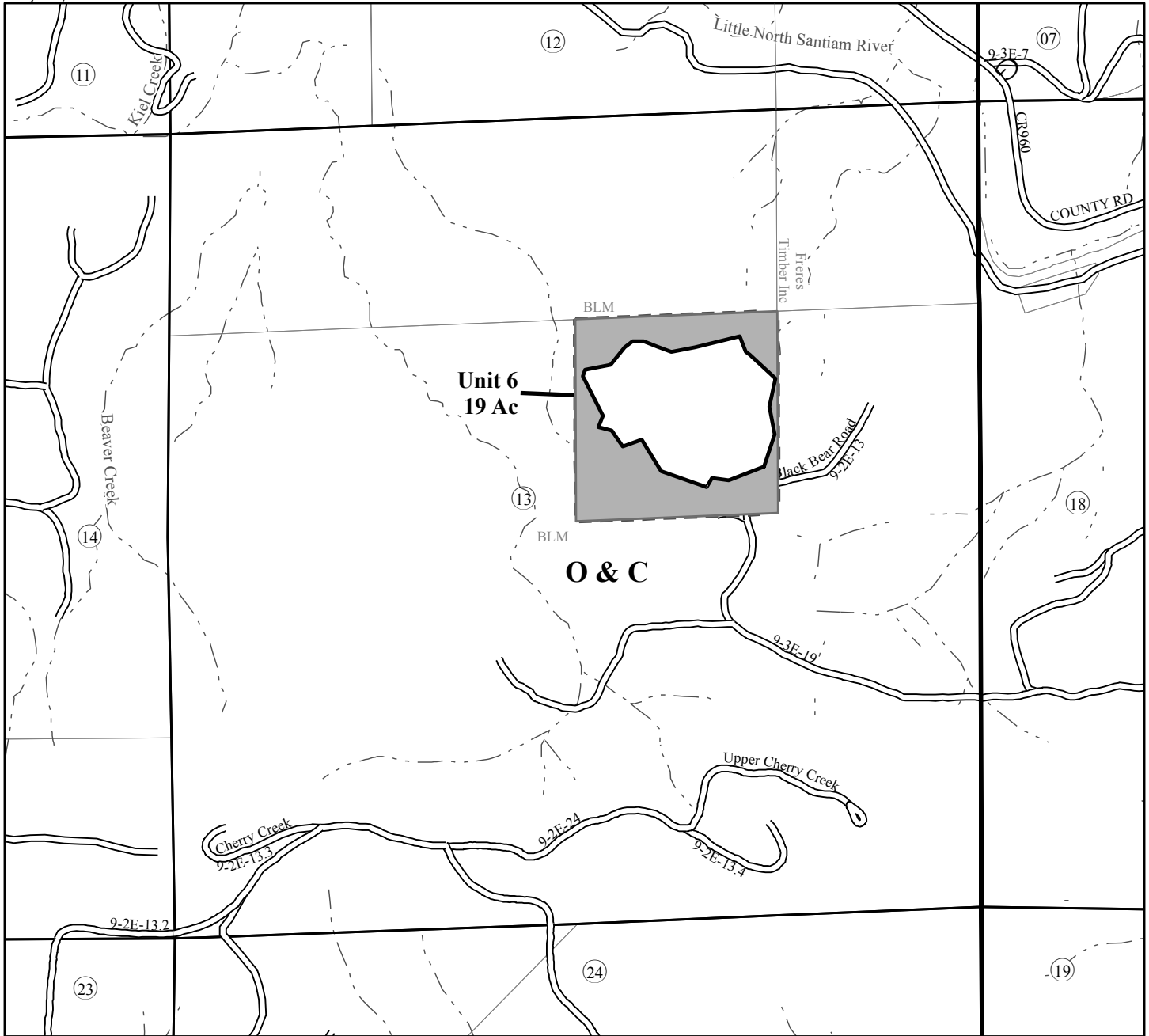

1,000 500 0 Feet

- Corner Found
- Existing Road
- == Highway
- - Stream
- Right-of-Way Road to be Constructed
- Right-of-Way Road to be Renovated

- G Gate
- Contract Area
- Reserve Area
- Partial Cut Area Unit Boundary
- Partial Cut Area - Skyline Yarding
- Partial Cut Area - Ground-Based Yarding

Partial Cut Area	354 Acres
Road Right of Way	8 Acres
Reserve Area	323.75 Acres
<b>Contract Area</b>	<b>691.75 Acres</b>

Contour Interval : 20'



Note: Boundaries of Partial Cut Area are painted orange and posted.

Note: Unit acres do not include existing or new roads. Acres shown on Exhibit A have been computed using a Trimble Geo XT global positioning system receiver. Acreage was calculated based on global positioning system traverse procedures including differential correction.

United States Department of the Interior  
 BUREAU OF LAND MANAGEMENT  
 Salem District - Oregon  
**TIMBER SALE CONTRACT MAP - Contract No. ORS040-TS12-502**  
 T.9S., R2E., sections 11,13 & 25 & T.9S., R.3E., Sections 17, 19 & 21 W. M.

May 15, 2012

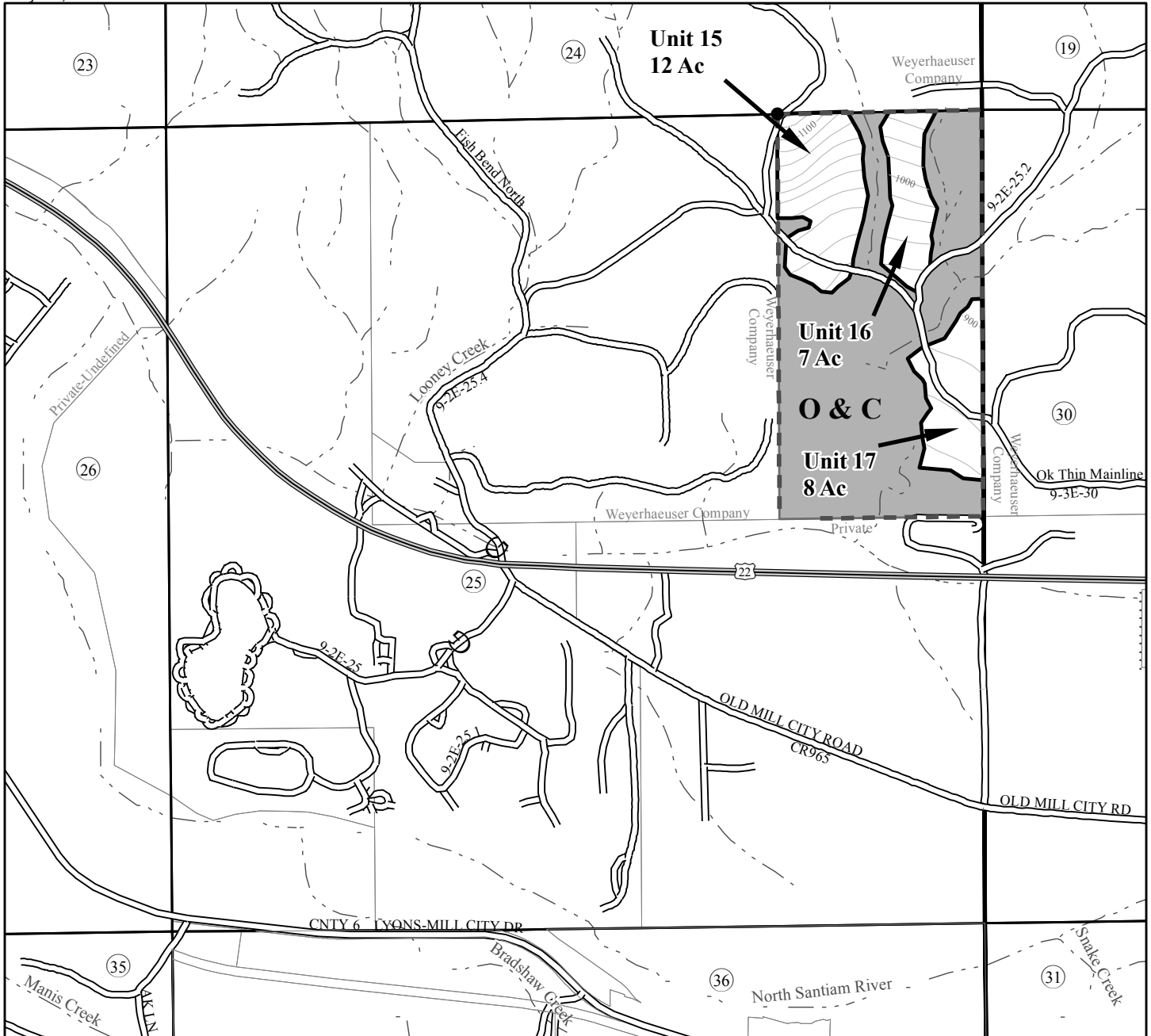

1,000 500 0 Feet

- Corner Found
- Existing Road
- == Highway
- - Stream
- Right-of-Way
- ⋯ Road to be Constructed
- Right-of-Way
- ⋯ Road to be Renovated

- G Gate
- Contract Area
- Reserve Area
- Partial Cut Area Unit Boundary
- Partial Cut Area - Skyline Yarding
- Partial Cut Area - Ground-Based Yarding

Partial Cut Area	354 Acres
Road Right of Way	8 Acres
Reserve Area	323.75 Acres
<b>Contract Area</b>	<b>691.75 Acres</b>

Contour Interval : 20'



Note: Boundaries of Partial Cut Area are painted orange and posted.

Note: Unit acres do not include existing or new roads. Acres shown on Exhibit A have been computed using a Trimble Geo XT global positioning system receiver. Acreage was calculated based on global positioning system traverse procedures including differential correction.

United States Department of the Interior  
 BUREAU OF LAND MANAGEMENT  
 Salem District - Oregon  
**TIMBER SALE CONTRACT MAP - Contract No. ORS040-TS12-502**  
 T.9S., R2E., sections 11,13 & 25 & T.9S., R.3E., Sections 17, 19 & 21 W. M.

Power Mill Thinning  
 Timber Sale  
 Exhibit A  
 Page 4 of 6

May 15, 2012

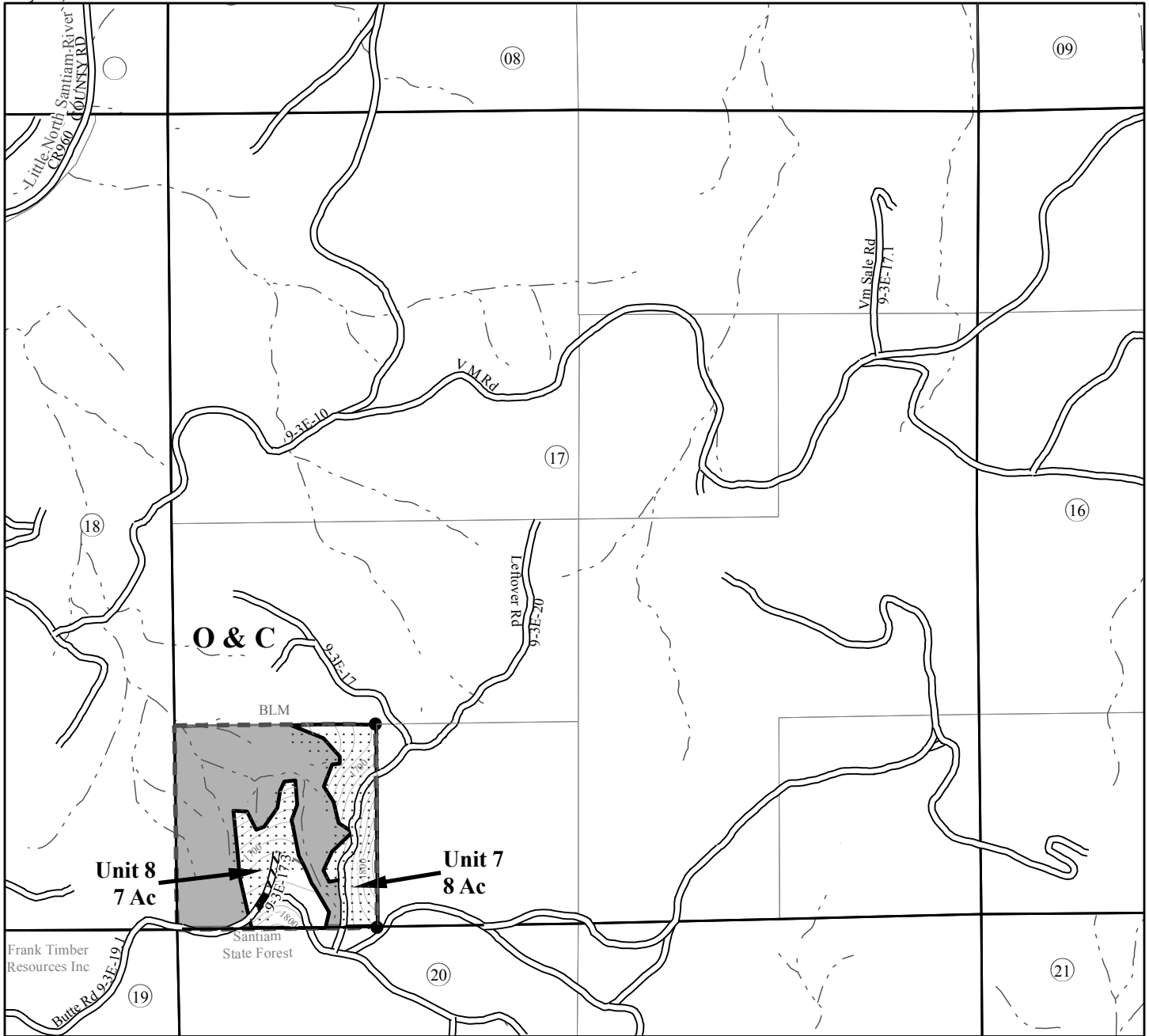

1,000 500 0 Feet

- Corner Found
- Existing Road
- == Highway
- - Stream
- Right-of-Way
- Road to be Constructed
- Right-of-Way
- /— Road to be Renovated

- G Gate
- Contract Area
- Reserve Area
- Partial Cut Area Unit Boundary
- Partial Cut Area - Skyline Yarding
- Partial Cut Area - Ground-Based Yarding

Partial Cut Area	354 Acres
Road Right of Way	8 Acres
Reserve Area	323.75 Acres
<b>Contract Area</b>	<b>691.75 Acres</b>

Contour Interval : 20'



Note: Boundaries of Partial Cut Area are painted orange and posted.

Note: Unit acres do not include existing or new roads. Acres shown on Exhibit A have been computed using a Trimble Geo XT global positioning system receiver. Acreage was calculated based on global positioning system traverse procedures including differential correction.

United States Department of the Interior  
 BUREAU OF LAND MANAGEMENT  
 Salem District - Oregon  
**TIMBER SALE CONTRACT MAP - Contract No. ORS040-TS12-502**  
 T.9S., R2E., sections 11,13 & 25 & T.9S., R.3E., Sections 17, 19 & 21 W. M.

May 15, 2012

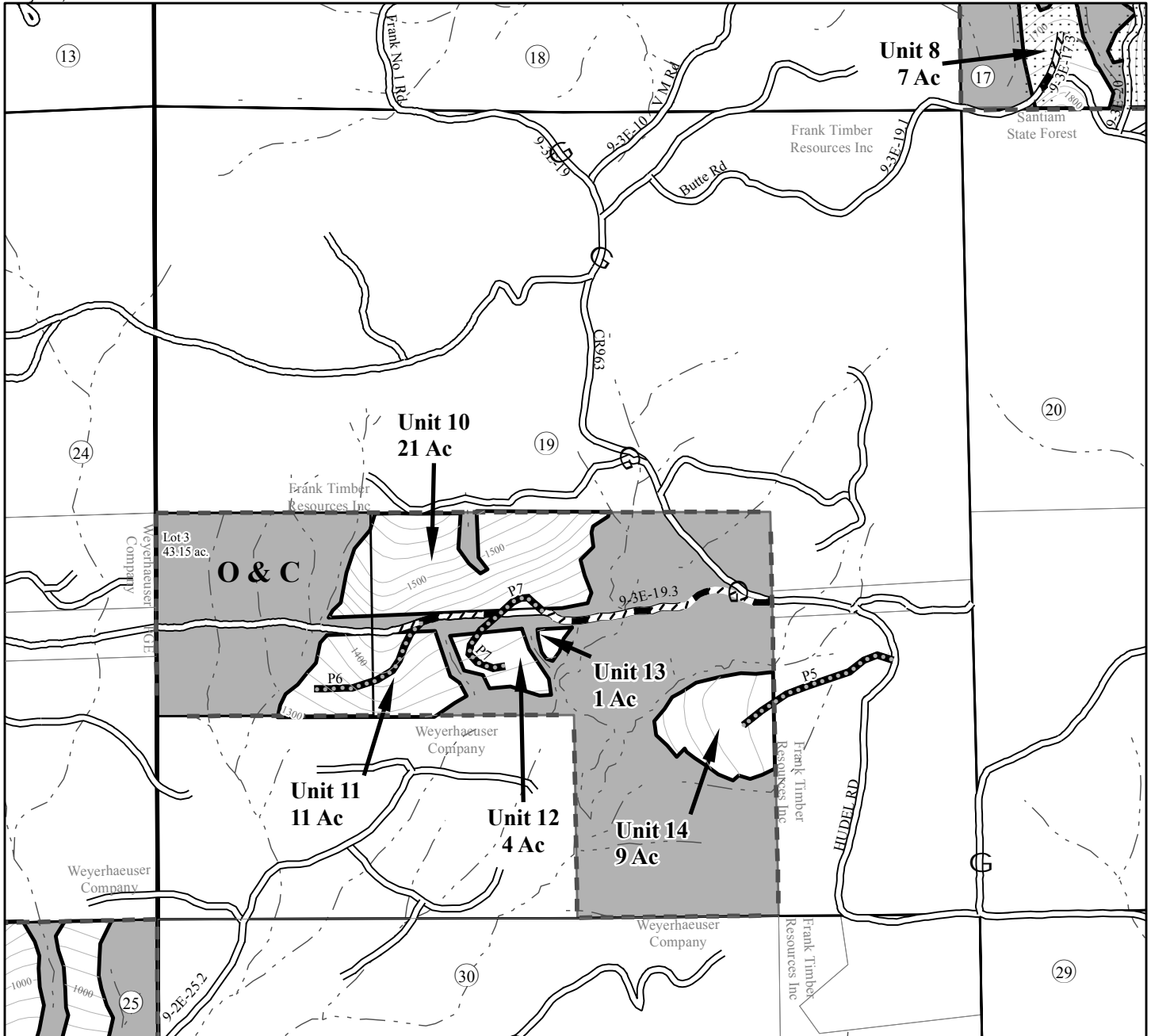

1,000 500 0 Feet

- Corner Found
- Existing Road
- == Highway
- - Stream
- Right-of-Way
- Right-of-Way Road to be Constructed
- Right-of-Way Road to be Renovated

- G Gate
- Contract Area
- Reserve Area
- Partial Cut Area Unit Boundary
- Partial Cut Area - Skyline Yarding
- Partial Cut Area - Ground-Based Yarding

Partial Cut Area	354 Acres
Road Right of Way	8 Acres
Reserve Area	323.75 Acres
<b>Contract Area</b>	<b>691.75 Acres</b>

Contour Interval : 20'



Note: Boundaries of Partial Cut Area are painted orange and posted.

Note: Unit acres do not include existing or new roads. Acres shown on Exhibit A have been computed using a Trimble Geo XT global positioning system receiver. Acreage was calculated based on global positioning system traverse procedures including differential correction.

United States Department of the Interior  
 BUREAU OF LAND MANAGEMENT  
 Salem District - Oregon  
**TIMBER SALE CONTRACT MAP - Contract No. ORS040-TS12-502**  
 T.9S., R2E., sections 11,13 & 25 & T.9S., R.3E., Sections 17, 19 & 21 W. M.

May 15, 2012

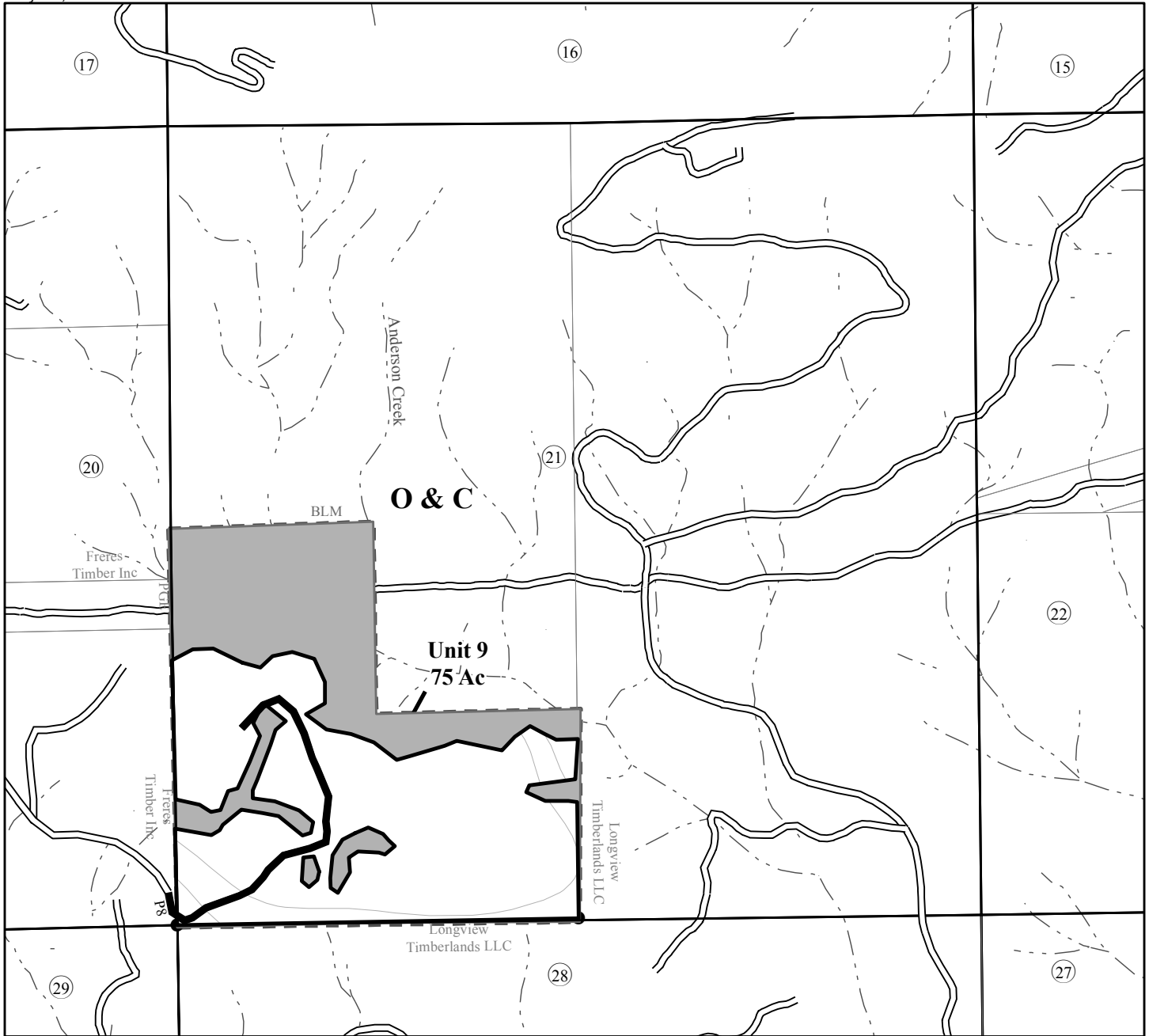

1,000 500 0 Feet

- Corner Found
- Existing Road
- == Highway
- - Stream
- Right-of-Way
- Road to be Constructed
- Right-of-Way
- Road to be Renovated

- G Gate
- Contract Area
- Reserve Area
- Partial Cut Area Unit Boundary
- Partial Cut Area - Skyline Yarding
- Partial Cut Area - Ground-Based Yarding

Partial Cut Area	354 Acres
Road Right of Way	8 Acres
Reserve Area	323.75 Acres
<b>Contract Area</b>	<b>691.75 Acres</b>

Contour Interval : 20'



Note: Boundaries of Partial Cut Area are painted orange and posted.

Note: Unit acres do not include existing or new roads. Acres shown on Exhibit A have been computed using a Trimble Geo XT global positioning system receiver. Acreage was calculated based on global positioning system traverse procedures including differential correction.

**UNITED STATES  
DEPARTMENT OF THE INTERIOR  
BUREAU OF LAND MANAGEMENT**

Salem  
Power Mill  
TS12-502

**Exhibit B**

The following estimates and calculations of timber sold are made solely as an administrative aid for determining: (1) Adjustments made or credits given in accordance with Sections 6, 9, or 11; (2) When payments are due; and (3) Value of timber subject to any special bonding provisions. The value of timber will be determined by multiplying the value per acre as shown below, times the amount of acreage as determined by the authorized officer, which has been cut or removed or designated for taking.

Except provided in Section 2, Purchaser shall be liable for the total purchase price even though the quantity of timber actually cut or removed or designated for taking is less than the estimated volume or quantity shown. Cutting areas are shown on the Exhibit A.

**Sale Totals (16' MBF)**

Species	Net Volume	Bid Price	Sale SubTotal
Douglas-fir	6,157		
Western Hemlock	494		
Grand Fir	100		
<b>Sale Totals</b>	<b>6,751</b>		

**Unit Details (16' MB)**

Unit PC U#t                      9 Acres                      Value per Acre : \$0.00

Species	Net Volume	Bid Price	Species Value
Douglas-fir	152		
Grand Fir	3		
Western Hemlock	13		
<b>Unit Totals</b>	<b>168</b>		

Unit PC U#10                      2t Acres                      Value per Acre : \$0.00

Species	Net Volume	Bid Price	Species Value
Douglas-fir	355		
Grand Fir	7		
Western Hemlock	31		
<b>Unit Totals</b>	<b>393</b>		

Unit PC U#tt                      tt Acres                      Value per Acre : \$0.00

Species	Net Volume	Bid Price	Species Value
Douglas-fir	186		
Grand Fir	3		
Western Hemlock	16		
<b>Unit Totals</b>	<b>205</b>		





**UNITED STATES  
DEPARTMENT OF THE INTERIOR  
BUREAU OF LAND MANAGEMENT**

Salem  
Power Mill  
TS12-502

**Unit PC U#2 120 Acres Value per Acre : \$0.00**

Species	Net Volume	Bid Price	Species Value
Douglas-fir	2,045		
Grand Fir	38		
Western Hemlock	179		
<b>Unit Totals</b>	<b>2,262</b>		

**Unit PC U#3 20 Acres Value per Acre : \$0.00**

Species	Net Volume	Bid Price	Species Value
Douglas-fir	338		
Grand Fir	6		
Western Hemlock	29		
<b>Unit Totals</b>	<b>373</b>		

**Unit PC U#4 6 Acres Value per Acre : \$0.00**

Species	Net Volume	Bid Price	Species Value
Douglas-fir	101		
Grand Fir	2		
Western Hemlock	9		
<b>Unit Totals</b>	<b>112</b>		

**Unit PC U#5 17 Acres Value per Acre : \$0.00**

Species	Net Volume	Bid Price	Species Value
Douglas-fir	316		
Grand Fir	5		
Western Hemlock	28		
<b>Unit Totals</b>	<b>349</b>		

**Unit PC U#6 19 Acres Value per Acre : \$0.00**

Species	Net Volume	Bid Price	Species Value
Douglas-fir	321		
Grand Fir	6		
Western Hemlock	28		
<b>Unit Totals</b>	<b>355</b>		





# CULVERT LIST

CULVERT LOCATIONS										DOWNSPOUT					REMARKS
DESIGNED						AS BUILT									
ROAD NO. STATION OR M.P.	SIZE	MATL	LENGTH	SKEW ANGLE	INSTAL-LATION TYPE	ROAD NO. STATION OR M.P.	SIZE	GAGE	LENGTH	TYPE	SIZE	LENGTH	TYPE OF ELBOW	CULVERT MARKERS	
9-2E-12.1															
C2-D1															
#1	36	CMP	34		3									1	Live - build ditch on both sides
#2	36	CMP	34		3									1	Remove Log Fill
#3	36	CMP	50		3									1	Remove Log Fill
#4	36	CMP	36		1									1	Live - Pond
#5	36	CMP	36		1									1	Live - Remove log fills - drop outlet 6ft.
#6	24	CPP	32		1									1	Live
#7	24	CPP	30		1									1	Live
9-2E-13															
#13 (0,10)	24	CPP	40		3									1	Cross drain
9-3E-19															
#14 (1.09)	24	CPP	30		1					CPP	24	20	2	1	Live
#15 (1.20)	24	CPP	40		3									1	Cross drain
9-3E-19.3															
#9	18	CPP	30		3									1	Cross drain
#10	48	CMP	30		1									1	Live
P12															
#11 (8+90)	24	CPP	40		1									1	Live
#12 (10+65)	24	CPP	40		1									1	Live

**NOTE:**

- DESIGNED CULVERT LENGTHS AND LOCATIONS ARE APPROXIMATE.
- ALL CULVERTS HAVE 2 2/3" X 1/2" CORRUGATIONS UNLESS OTHERWISE NOTED.
- SEE CULVERT INSTALLATION SHEET.
- DOWNSPOUT TYPES;
  - FULL ROUND
  - HALF ROUND
  - RECTANGULAR FLUME
- ELBOW TYPES;
  - CONVENTIONAL OR FABRICATED
  - TURNER TYPE
  - SLIP JOINT.
- INCLUDE SPECIAL SECTIONS, STRUCTURES, HEADWALLS, FOOTINGS, AND OTHER DATA.

GAGE CHART STEEL & ALUM.		
GAGE	DEC. EQUIV. INCHES	
	STEEL	ALUM.
10	.138	.135
12	.109	.105
14	.079	.075
16	.064	.060

ALWAYS THINK SAFETY

UNITED STATES DEPARTMENT OF THE INTERIOR Bureau of Land Management SALEM DISTRICT - OREGON	
<b>CULVERT SUMMARY</b>	
DESIGN & REVISION BY: _____	SCALE: not to scale
DATE: 1990	SHEET 1 of 1

PIPE ARCH CULVERT				
MATL	SIZE	GAGE	CORRUGATIONS	LENGTH

STRUCTURAL PLATE CULVERT				
MATL	SIZE	GAGE	CORRUGATIONS	LENGTH

ROUND PIPE CULVERT				
MATL	SIZE	GAGE	CORRUGATIONS	LENGTH
CPP	18			30
CPP	24			252
CMP	36			190
CMP	48	12		30

DOWNSPOUTS		
TYPE	SIZE	LENGTH
CPP	24	20

U.S. DEPT. OF THE INTERIOR  
Bureau of Land Management  
SALEM DISTRICT - OREGON

Contract No.  
ORS040-TS12-502

Site  
Power Mill  
Thinning

Sheet 19 of 35

# GATE CONSTRUCTION DETAIL

## DETAIL SHEET

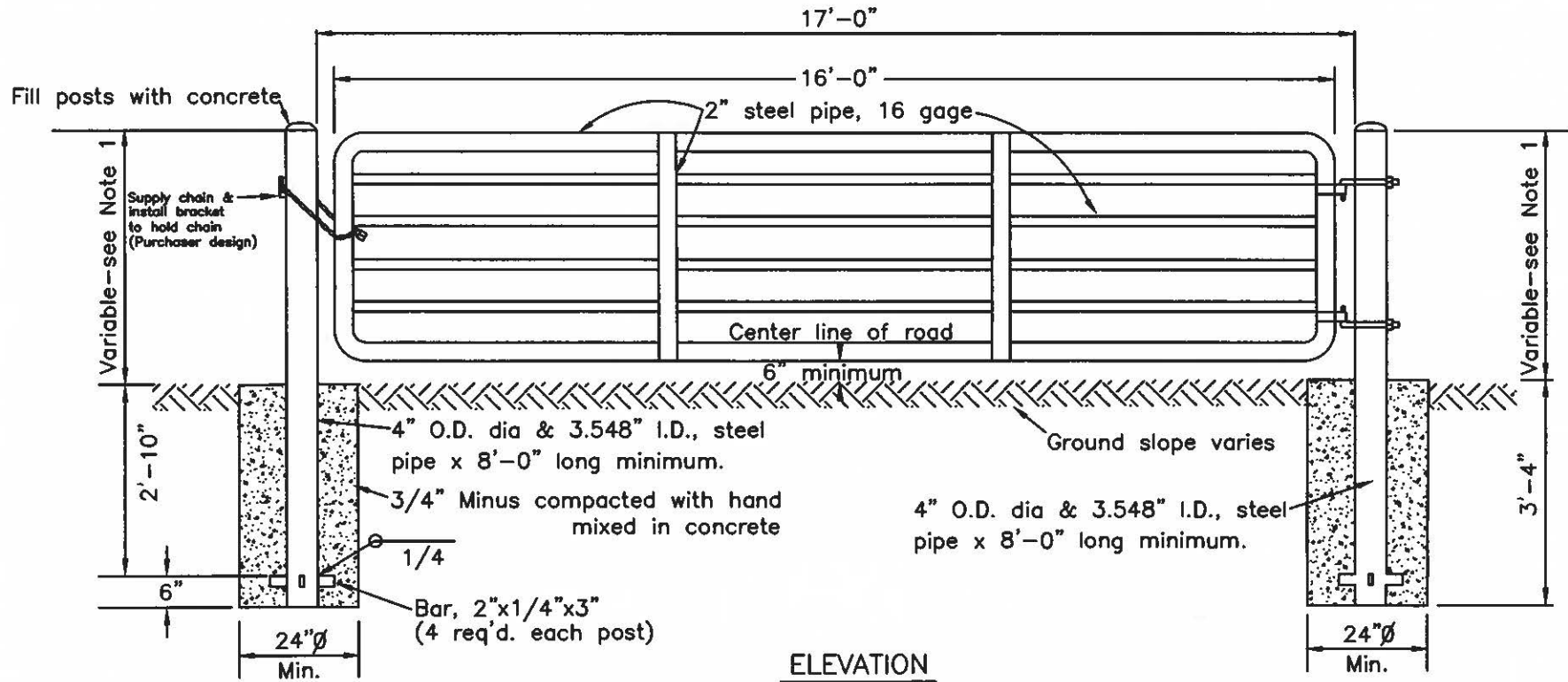

### NOTES:

1. Post height dimension shall be the same as required for the gate height
2. Supply sufficient amount of 1 3/4" X 1 1/4" case harden chain to lock gate
3. Threads on hinges shall be jammed to prevent removal.
4. All exposed surface of the crushed rock shall be crowned to shed water.
5. Paint posts same color as gate, use a steel primer paint before final finish paint is applied.

### WELDING SYMBOL LEGEND



Sheet 30 of 35

Sale Power Mill  
Thinning

Contract No.  
ORS040-TS12-502

U.S. DEPT. OF THE INTERIOR  
Bureau of Land Management  
SALEM DISTRICT - OREGON

UNITED STATES  
 DEPARTMENT OF THE INTERIOR  
 ROAD PLAN MAP  
 Sections 1, 2, 10, 11, and 12, T. 9 S., R. 2 E., W.M.

EXHIBIT C  
 ORS040-TS12-502  
 Power Mill Timber Sale  
 Sheet 34 of 35

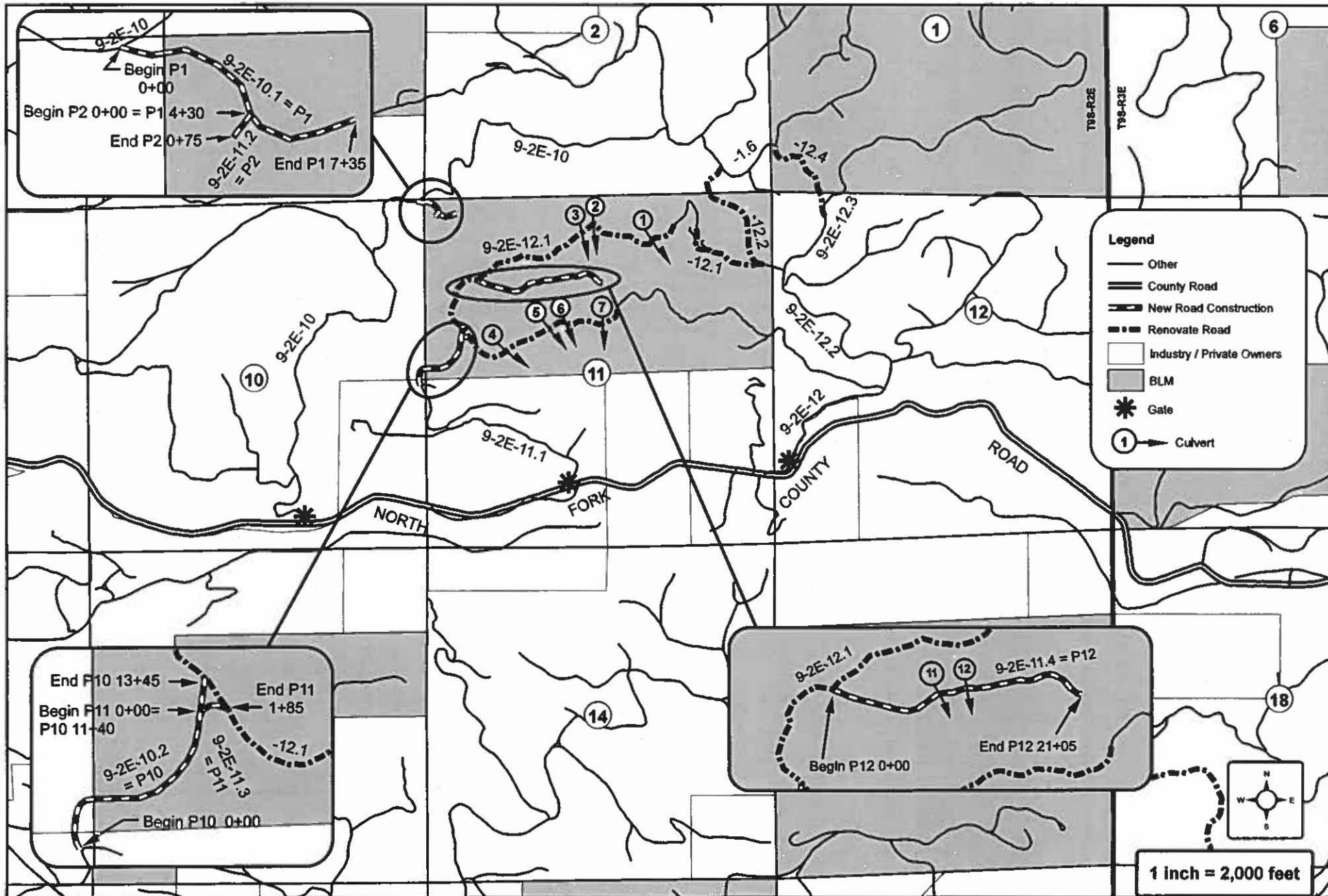

UNITED STATES  
 DEPARTMENT OF THE INTERIOR  
 ROAD PLAN MAP  
 Sections 1, 2, 10, 11, and 12, T. 9 S., R. 2 E., W.M.

EXHIBIT C  
 ORS040-TS12-502  
 Power Mill Timber Sale  
 Sheet 35 of 35

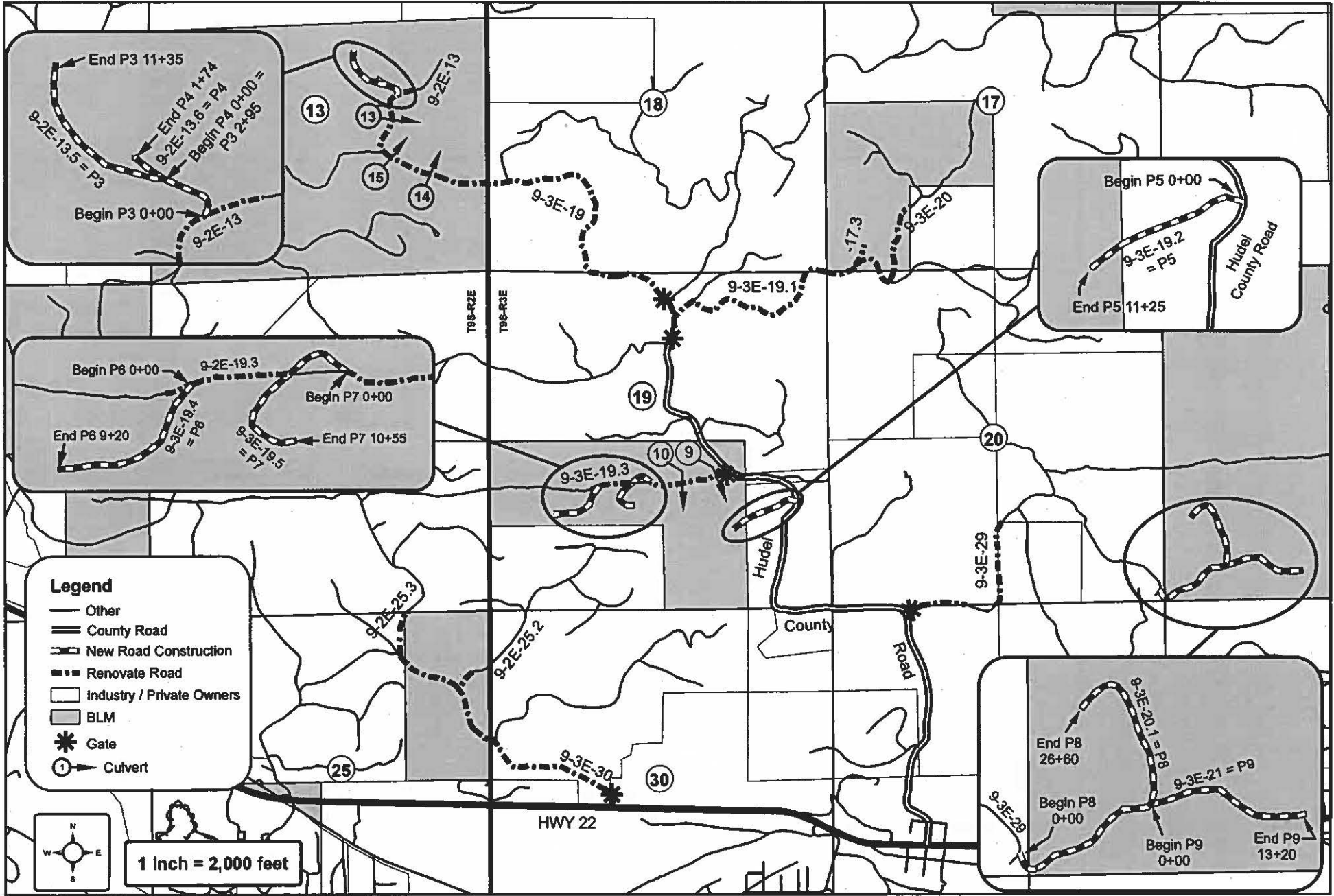

UNITED STATES  
 DEPARTMENT OF THE INTERIOR  
 ROAD USE AND MAINTENANCE MAP  
 Sections 1, 2, 10, 11, and 12, T. 9 S., R. 2 E., W.M.

EXHIBIT E  
 ORS040-TS12-502  
 Power Mill Timber Sale  
 Sheet 1 of 2

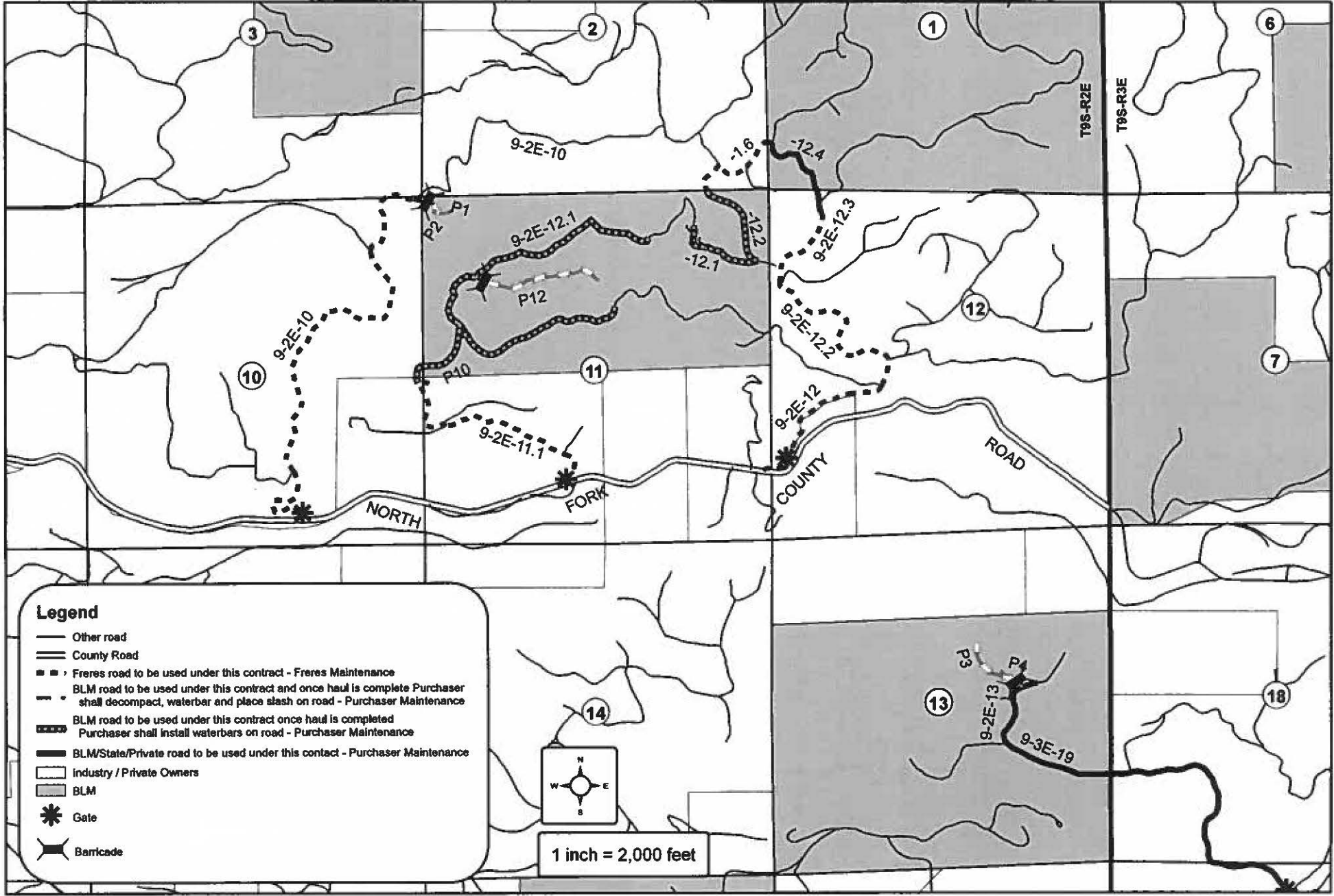

**Legend**

- Other road
- == County Road
- ▣ Freres road to be used under this contract - Freres Maintenance
- ▣ BLM road to be used under this contract and once haul is complete Purchaser shall decompact, waterbar and place slash on road - Purchaser Maintenance
- ▣ BLM road to be used under this contract once haul is completed Purchaser shall install waterbars on road - Purchaser Maintenance
- ▣ BLM/State/Private road to be used under this contact - Purchaser Maintenance
- Industry / Private Owners
- ▣ BLM
- \* Gate
- ▣ Barricade

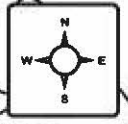

1 inch = 2,000 feet



UNITED STATES  
 DEPARTMENT OF THE INTERIOR  
 ROAD USE AND MAINTENANCE MAP  
 Sections 1, 2, 10, 11, and 12, T. 9 S., R. 2 E., W.M.

EXHIBIT E  
 ORS040-TS12-502  
 Power Mill Timber Sale  
 Sheet 2 of 2

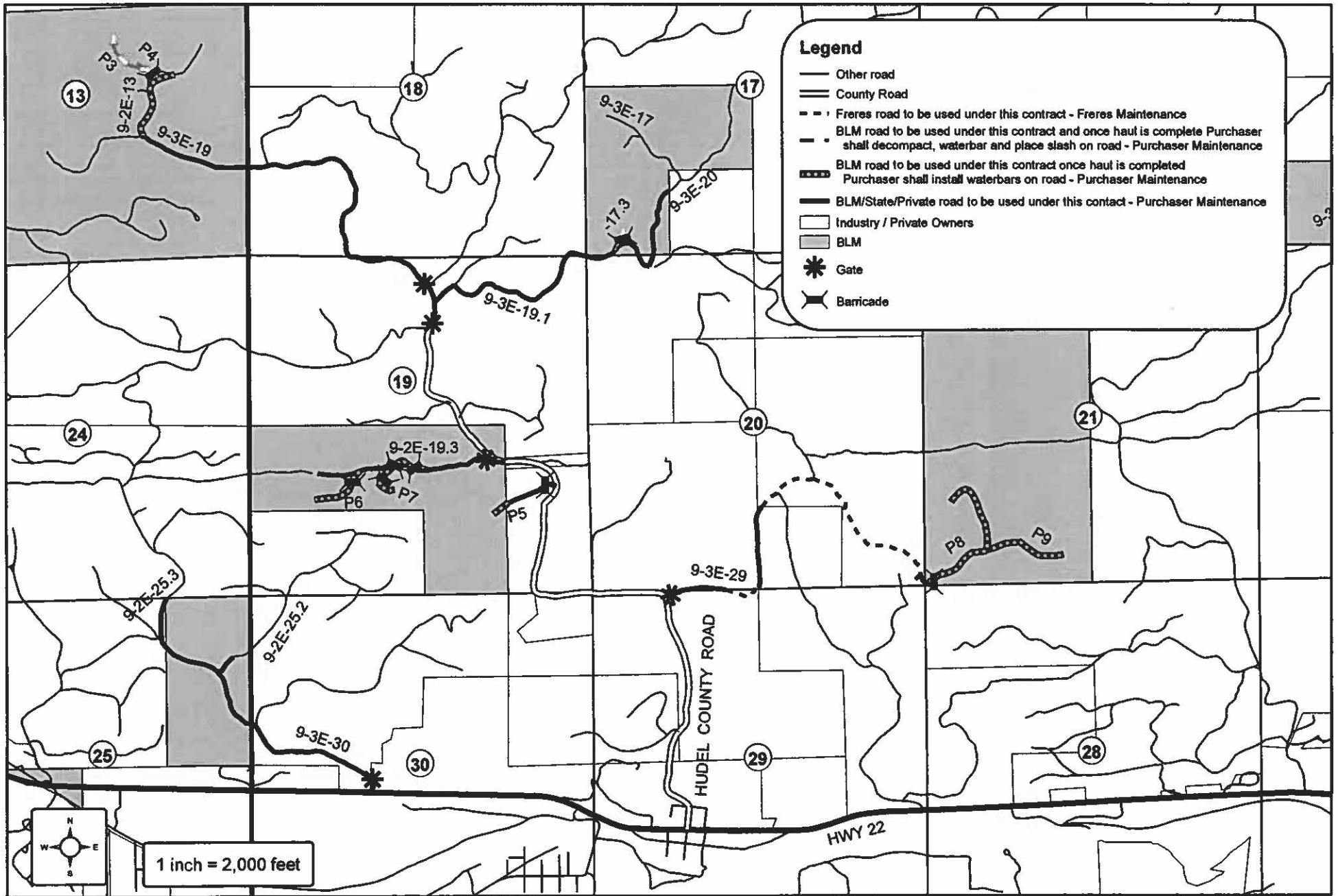

United States Department of the Interior  
**BUREAU OF LAND MANAGEMENT**  
 Salem District - Oregon  
**TIMBER SALE CONTRACT MAP - Contract No. ORS040-TS12-502**  
 T.9S., R2E., section 11 & T.9S., R.3E., Section 21 W. M.

Power Mill Thinning  
 Timber Sale  
 Exhibit F  
 Page 1 of 2

May 03, 2012

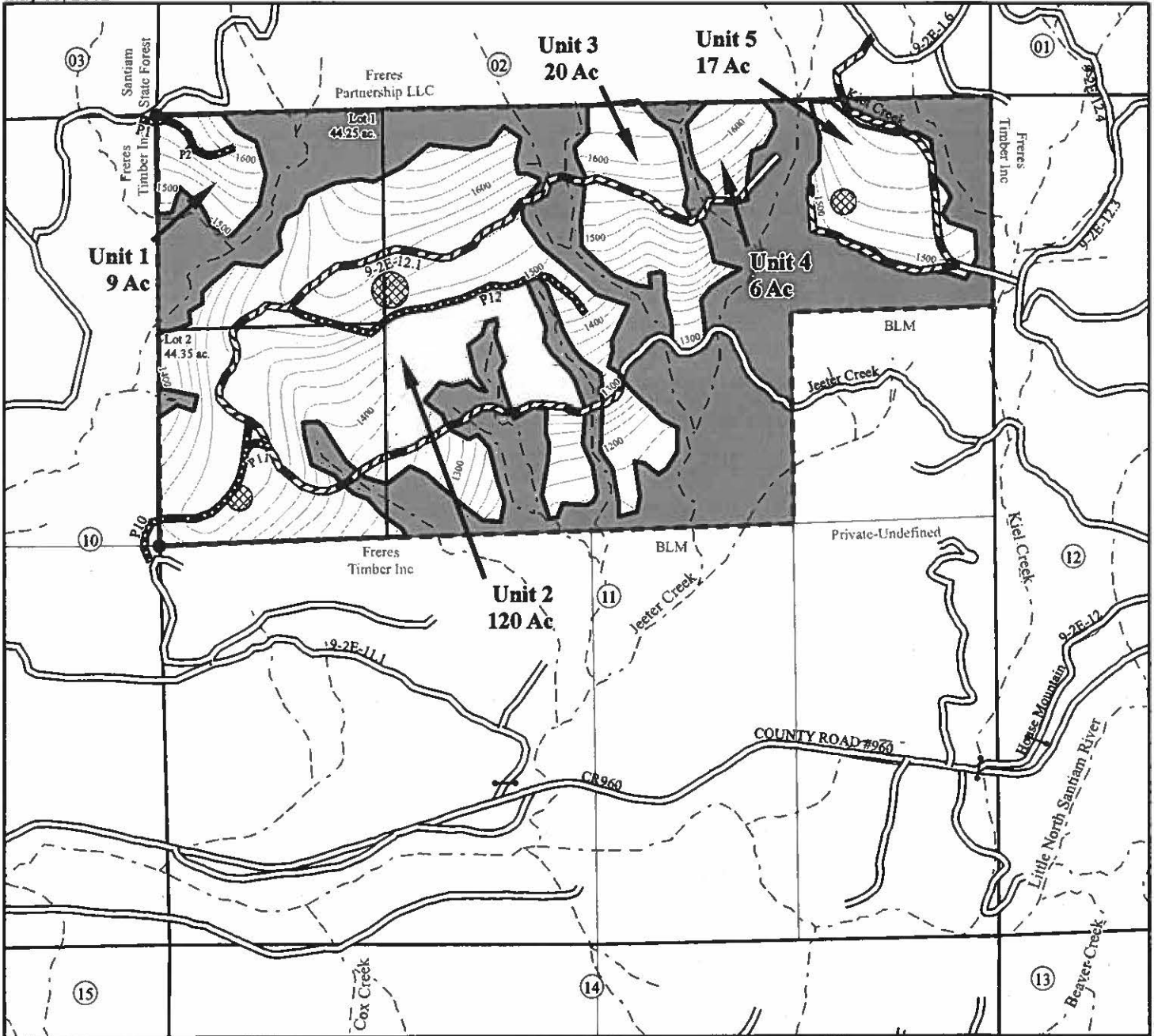

- Corner Found
- ⊗ LD Area
- ══ Existing Road
- ══ Highway
- - - Stream
- ⊢ Right-of-Way
- ⊢⊢ Road to be Constructed
- ⊢⊢ Right-of-Way
- ⊢⊢ Road to be Renovated
- ⊢ Gate
- ⊢⊢ Contract Area
- ⊢ Reserve Area
- ⊢ Partial Cut Area Unit Boundary

Contour Interval : 20'



Note: Boundaries of Partial Cut Area are painted orange and posted.

Note: Unit acres do not include existing or new roads. Acres shown on Exhibit A have been computed using a Trimble Geo XT global positioning system receiver. Acreage was calculated based on global positioning system traverse procedures including differential correction.

United States Department of the Interior  
 BUREAU OF LAND MANAGEMENT  
 Salem District - Oregon  
**TIMBER SALE CONTRACT MAP - Contract No. ORS040-TS12-502**  
 T.9S., R2E., section 11 & T.9S., R.3E., Section 21 W. M.

Power Mill Thinning  
 Timber Sale  
 Exhibit F  
 Page 2 of 2

May 03, 2012

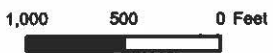
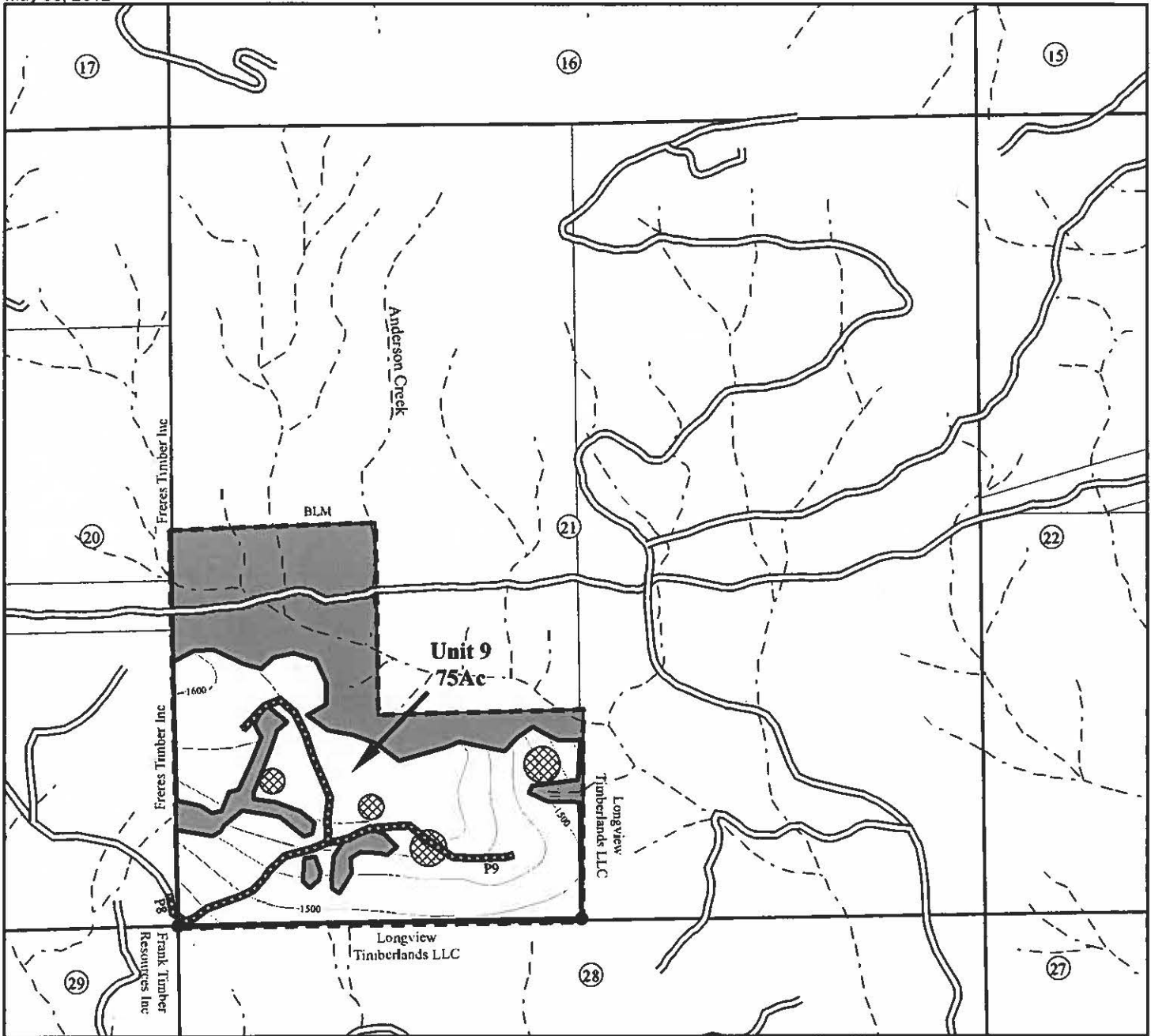

- Corner Found
- ⊗ LD Area
- Existing Road
- Gate
- Highway
- - - Contract Area
- - - Stream
- █ Reserve Area
- Right-of-Way
- ▬ Road to be Constructed
- ▬ Right-of-Way
- ▬ Road to be Renovated
- Partial Cut Area Unit Boundary

Contour Interval : 20'



Note: Boundaries of Partial Cut Area are painted orange and posted.

Note: Unit acres do not include existing or new roads. Acres shown on Exhibit A have been computed using a Trimble Geo XT global positioning system receiver. Acreage was calculated based on global positioning system traverse procedures including differential correction.

**SPECIAL PROVISIONS FOR MACHINE PILING AND PILE COVERING**

1. Piling of brush and logging debris shall be performed with a track mounted hydraulic excavator referred to as a "shovel" in this contract. The shovel shall be equipped with a controllable grapple head or hydraulic thumb capable of picking up logging slash and debris without also picking up more than minimal soil. The shovel shall have a minimum reach of twenty (20) feet. Prior to commencement of piling work, all equipment shall meet the approval of the Authorized Officer. The shovel shall be cleaned in accordance with section 41.dd.
2. The shovel shall not operate on slopes greater than thirty-five (35) percent.
3. The Purchaser shall operate the shovel so as to keep the tracks of the shovel on top of unpiled slash and/or brush and to make no more than one pass over any single spot on the ground. Areas receiving more than one pass shall be tilled in accordance with the instructions of the Authorized Officer if, in the opinion of the Authorized Officer, compaction has occurred.
4. Logging slash and debris smaller than six (6) inches diameter, large end, and longer than four (4) feet, shall be piled so that the remaining slash and debris shall average less than four (4) inches deep and shall not have any concentration of slash and debris more than eight (8) inches deep. Remaining slash and debris shall not be matted so that it would, in the opinion of the Authorized Officer, be continuous enough to carry fire during the dry season.
5. Logging slash and debris and brush shall be piled as directed by the Authorized Officer. Piles shall be tight, free of dirt, and free of projecting limbs or slash which would interfere with adequate pile covering. If, in the opinion of the Authorized Officer, the structure of the piles will not permit adequate consumption of piled debris by burning, the Purchaser shall re-pile them at the direction of the Authorized Officer.
6. Piles shall be located in areas suitable for burning as determined by the Authorized Officer. The piles shall not be closer than thirty (30) feet from the unit boundary or in locations which, in the opinion of the Authorized Officer, would endanger reserve trees.
7. Upon completion of piling, the Purchaser shall prepare the landing piles for burning by securely covering each landing pile by securely covering each pile with polyethylene plastic film a minimum of .004 inch thick. Landing piles shall be covered with enough plastic to keep pile dry enough to ensure pile consumption. Woody debris shall then be placed on top of the plastic so that both sides and the middle are held in place during strong wind conditions. The Purchaser is required to furnish the covering materials. The timing of this covering work shall be in accordance with instructions from the Authorized Officer.

**SLASH PULLBACK**

All logging slash greater than two (2) feet long and between one (1) inch and six (6) inches in diameter at the large end should be completely removed at least fifty (50) feet (horizontal distance) from the edges of designated property lines to reduce the fire hazard. Larger material which has a portion meeting this specification must be bucked at the six (6) inch diameter and that portion pulled back. Slash shall not be piled, or windrowed. Slash shall be scattered over the site so that the slash is no more than one-foot in depth, measured from mineral soil.

U.S. DEPARTMENT OF THE INTERIOR  
 Bureau of Land Management  
 Salem District

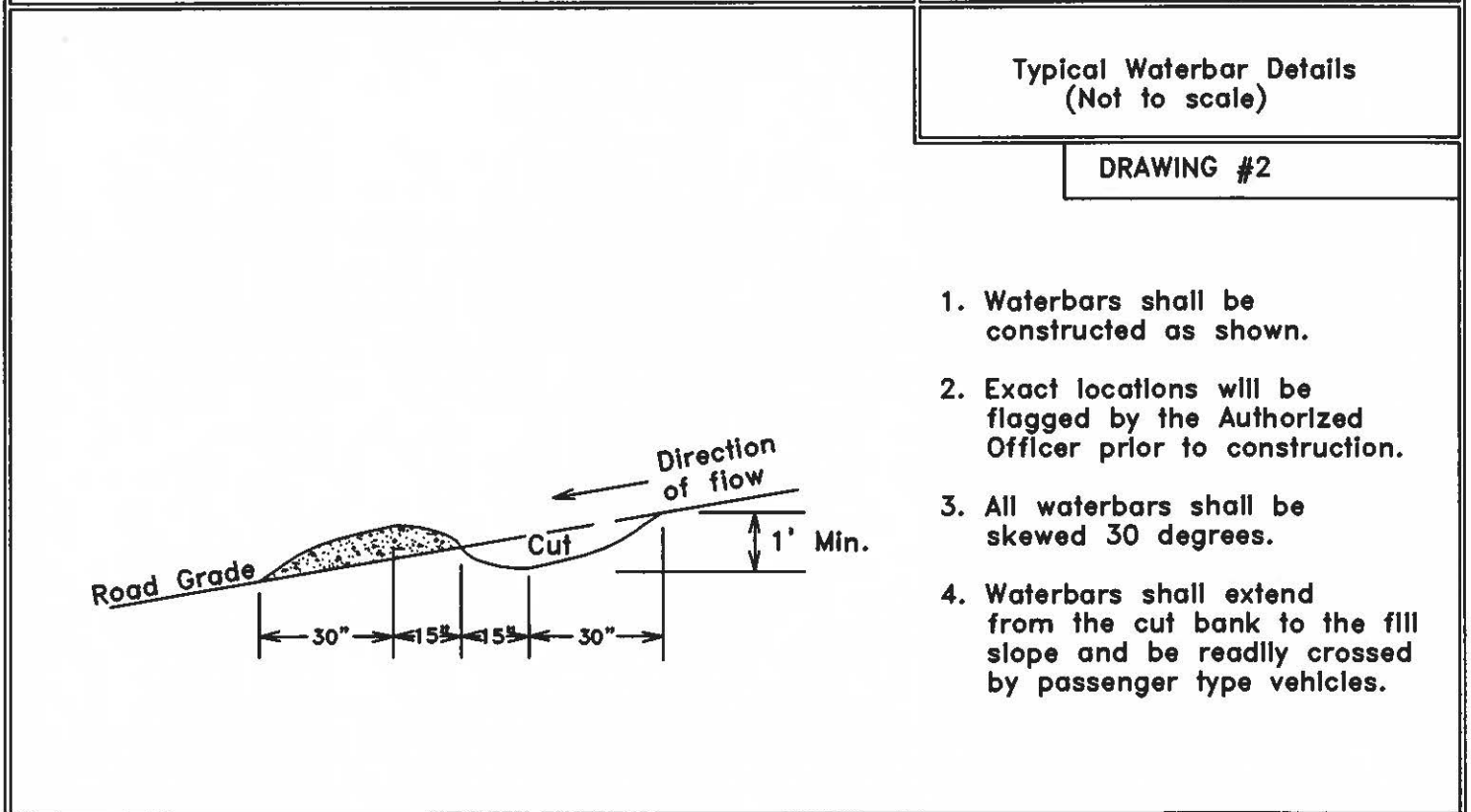
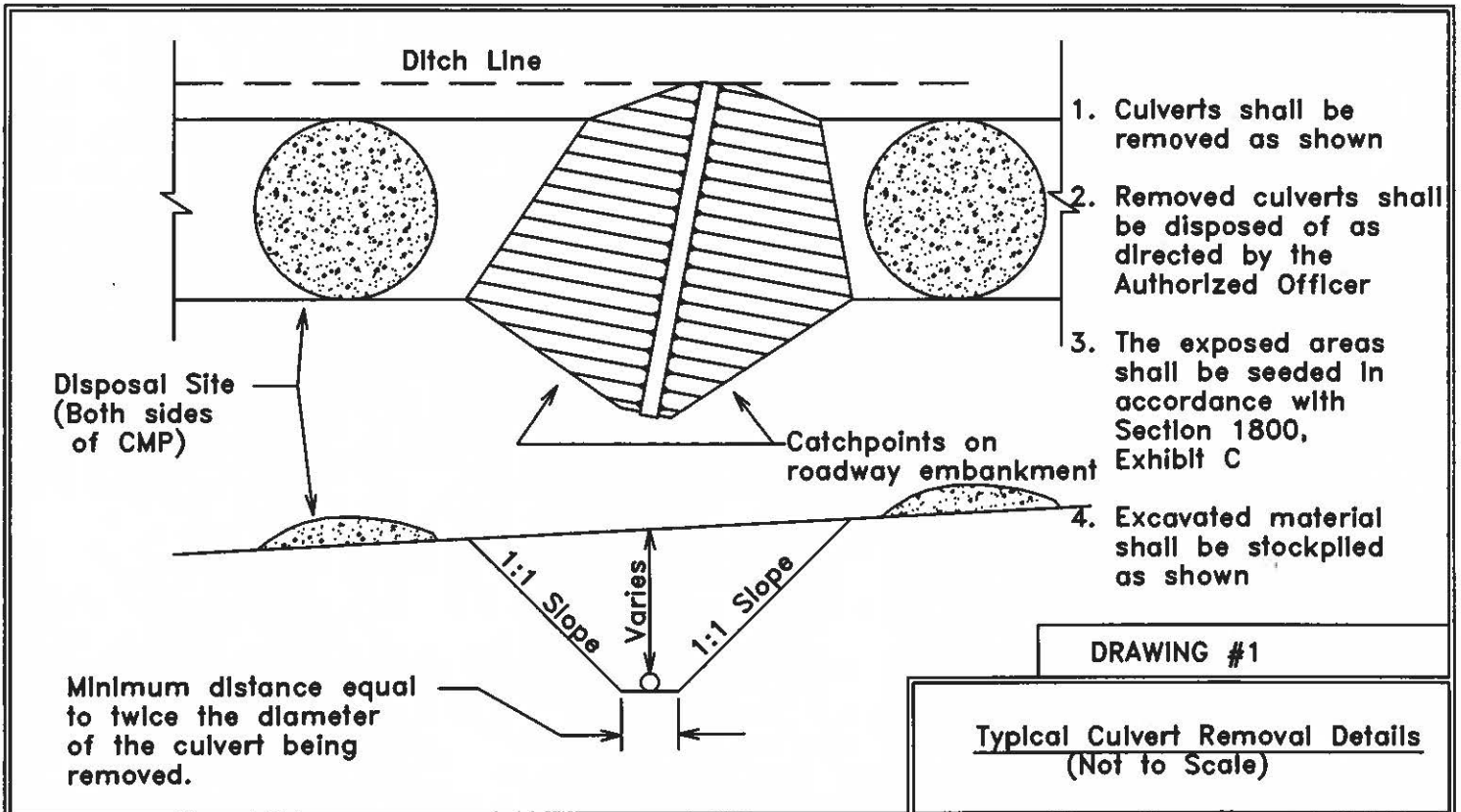

U.S. DEPARTMENT OF THE INTERIOR  
 Bureau of Land Management  
 Salem District

1. Roads shall be blocked as shown
2. All excavated material shall be stockpiled at the entrance of the road to be blocked
3. Exact locations will be flagged by the Authorized Officer prior to construction
4. The barricade shall span the entire width of the roadway and shall sufficiently block all vehicular access to the road

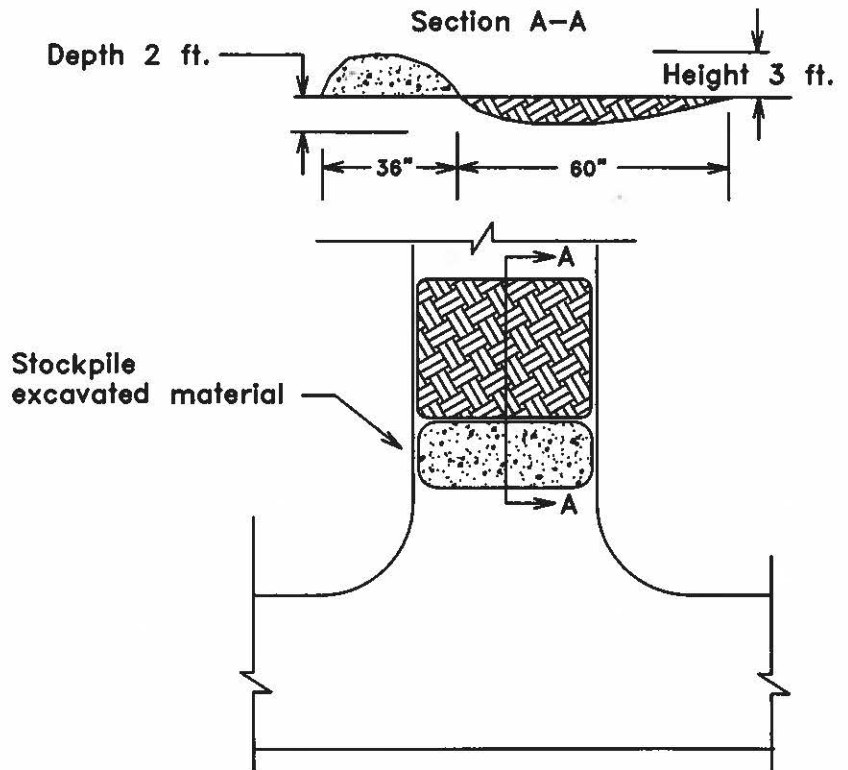

DRAWING #3

Typical Earth Barricade Details  
 (Earth berm)  
 (Not to Scale)

Typical Debris Barricade Details  
 (Debris & Earth berm)  
 (Not to Scale)

DRAWING #4

1. Roads shall be blocked as shown using available debris
2. All barricade material shall be stock piled in a large configuration of stumps, logs, large rocks, woody material and earth. Earth will be used to aid debris from being cut, stolen or moved from site.
3. Barricade locations will be flagged by the Authorized Officer prior to construction
4. The barricade shall span the entire width of the roadway and shall sufficiently block all vehicular access to the road

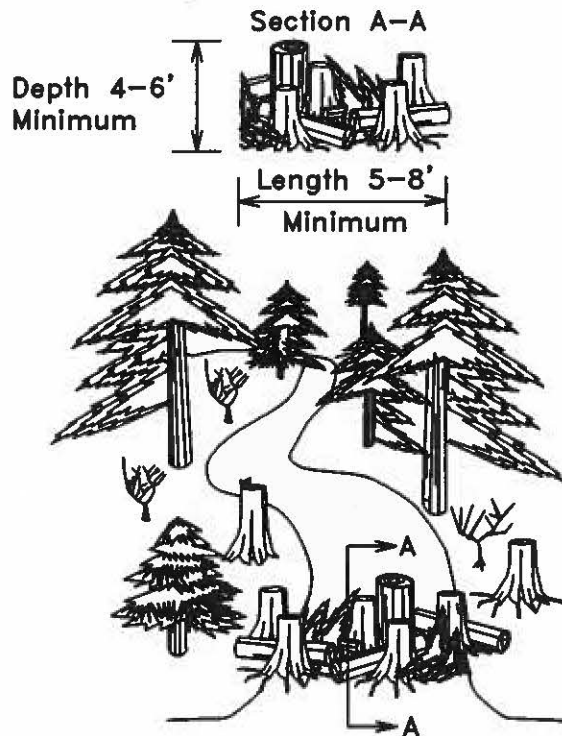

UNITED STATES  
DEPARTMENT OF THE INTERIOR  
BUREAU OF LAND MANAGEMENT  
Timber - Sale - Summary

Salem  
Power Mill  
TS12-502

**Legal Description**

Forest Type	Township	Range	Section	Subdivision
O&C	09S	02E	11	Lots 1 & 2, N1/2NE1/4, SW1/4NE1/4, E1/2NW1/4, WM
O&C	09S	02E	13	SW1/4NE1/4, WM
O&C	09S	02E	25	E1/2NE1/4, WM
O&C	09S	03E	17	SW1/4SW1/4, WM
O&C	09S	03E	19	Lot 3, NE1/4SW1/4, W1/2SE1/4, WM
O&C	09S	03E	21	W1/2SW1/4, SE1/4SW1/4, WM

**Cutting Volume (16' MBF)**

Unit	DF	WH	GF						Total	Regen	Partial	ROW
PC U#1	152	13	3						168	0	9	0
PC U#2	2,045	179	38						2,262	0	120	0
PC U#3	338	29	6						373	0	20	0
PC U#4	101	9	2						112	0	6	0
PC U#5	316	28	5						349	0	17	0
PC U#6	321	28	6						355	0	19	0
PC U#7	135	12	2						149	0	8	0
PC U#8	118	10	2						130	0	7	0
PC U#9	1,297	113	22						1,432	0	75	0
PC U#10	355	31	7						393	0	21	0
PC U#11	186	16	3						205	0	11	0
PC U#12	68	6	1						75	0	4	0
PC U#13	17	1	0						18	0	1	0
PC U#14	152	13	3						168	0	9	0
PC U#15	111								111	0	12	0
PC U#16	47								47	0	7	0
PC U#17	77								77	0	8	0
ROW	321	6							327	0	0	8
<b>Totals</b>	<b>6,157</b>	<b>494</b>	<b>100</b>						<b>6,751</b>	<b>0</b>	<b>354</b>	<b>8</b>



**UNITED STATES  
DEPARTMENT OF THE INTERIOR  
BUREAU OF LAND MANAGEMENT**

Salem  
Power Mill  
TS12-502

**Logging Costs per 16' MBF**

Stump to Truck	\$	142.36
Transportation	\$	28.13
Road Construction	\$	13.78
Road Amortization	\$	1.60
Road Maintenance	\$	4.26

Other Allowances :

Equipment Washing	\$ 0.05
Misc	\$ 0.24
Piling	\$ 1.14
Water Bars/ Berms	\$ 0.09
<b>Total Other Allowances :</b>	<b>\$ 1.52</b>

Total Logging Costs per 16' MBF

**\$ 191.65**

**Utilization Centers**

Center #1 : Mill City	8 Miles
Center #2	0 Miles
Weighted distance to Utilization Centers	8

**Length of Contract**

Cutting and Removal Time	36 Months
Personal Property Removal Time	1 Months

**Profit & Risk**

Total Profit & Risk		11 %
Basic Profit & Risk	11 % + Additional Risk	0 %
Back Off		0 %

**Tract Features**

Avg Log	Douglas-fir : 49 bf	All : 50 bf
Recovery	Douglas-fir : 97 %	All : 97 %
Salvage	Douglas-fir : 0 %	All : 0 %
Avg Volume ( 16' MBF per Acre)		19
Avg Yarding Slope		35 %
Avg Yarding Distance (feet)		500
Avg Age		75
Volume Cable		35 %
Volume Ground		65 %
Volume Aerial		0 %
Road Construction Stations		128.34
Road Improvement Stations		0.00
Road Renovation Stations		538.56
Road Decommission Stations		222.32

**Cruise**

Cruised By	P. Hazen
Date	10/01/2011
Type of Cruise	V-Plot, 100%, Sample Tree
County, State	Marion, OR

**Net Volume**

Green (16' MBF)	6,751
Salvage (16' MBF)	0
Douglas-fir Peeler	0
Export Volume	0
Scaling Allowance (\$0.00 per 16' MBF)	\$0.00

**UNITED STATES  
DEPARTMENT OF THE INTERIOR  
BUREAU OF LAND MANAGEMENT**

Salem  
Power Mill  
TS12-502

**Stumpage Summary**

**Stumpage Computation (16' MBF)**

Species	Trees	Net Volume	Pond Value	(-) Profit & Risk	(-) Logging Cost	(+) Marginal Log Value	(-) Back Off	Appraised Price	Appraised Value
DF	26,737	6,157	\$ 478.74	\$ 52.66	\$ 191.65			\$ 234.40	\$ 1,443,200.80
WH	2,510	494	\$ 373.67	\$ 41.10	\$ 191.65			\$ 140.90	\$ 69,604.60
GF	282	100	\$ 380.73	\$ 41.88	\$ 191.65			\$ 147.20	\$ 14,720.00
<b>Totals</b>	<b>29,529</b>	<b>6,751</b>							<b>\$ 1,527,525.40</b>

**Log Code by Percent**

Species	Code #1	Code #2	Code #3	Code #4	Code #5	Code #6
Douglas-fir				41.0	51.0	8.0
Western Hemlock				49.0	44.0	7.0
Grand Fir				53.0	44.0	3.0

**Marginal Log Volume**

Species	Grade #7	Grade #8
Douglas-fir		
Western Hemlock		
Grand Fir		

**Appraised By :** Hazen, Pete

**Date :** 03/07/2012

**Area Approval By :**

**Date :**

**District Approval By :**

**Date :**

UNITED STATES  
DEPARTMENT OF THE INTERIOR  
BUREAU OF LAND MANAGEMENT

Salem  
Power Mill  
TS12-502

**Prospectus**

Appraisal Method : (16' MBF)

Species	Trees	Net Volume 16' MBF	Net Volume 32' MBF	Net Volume CCF
Douglas-fir	26,737	6,157	5,267	10,990
Western Hemlock	2,510	494	395	918
Grand Fir	282	100	81	177
<b>Total</b>	<b>29,529</b>	<b>6,751</b>	<b>5,743</b>	<b>12,085</b>

**All Species**

Gross Volume	Number Trees	Avg bf Volume Per Tree	DBH	Gross Merch Volume	Merch Logs	Avg bf Gross Merch Log
6,982	29,529	236	14.1	6,982	140,667	50

Merch Logs	Cull Logs	Total Logs	Logs per Tree	Net Volume	Gross Volume	Recovery
140,667	0	140,667	4.8	6,751	6,982	97 %

**Douglas-fir**

Gross Volume	Number Trees	Avg bf Volume Per Tree	DBH	Gross Merch Volume	Merch Logs	Avg bf Gross Merch Log
6,372	26,737	238	14.0	6,372	129,010	49

Merch Logs	Cull Logs	Total Logs	Logs per Tree	Net Volume	Gross Volume	Recovery
129,010	0	129,010	4.8	6,157	6,372	97 %

United States Department of the Interior  
 BUREAU OF LAND MANAGEMENT  
**TIMBER SALE CONTRACT LOCATION MAP**

Power Mill Thinning  
 Timber Sale  
 Location Map  
 Page 1 of 1

Contract No. ORS040-TS12-502  
 T.9S., R2E., sections 11,13 & 25 & T.9S., R.3E., Sections 17, 19 & 21  
 W. M. - SALEM DISTRICT - OREGON

5/1/2012

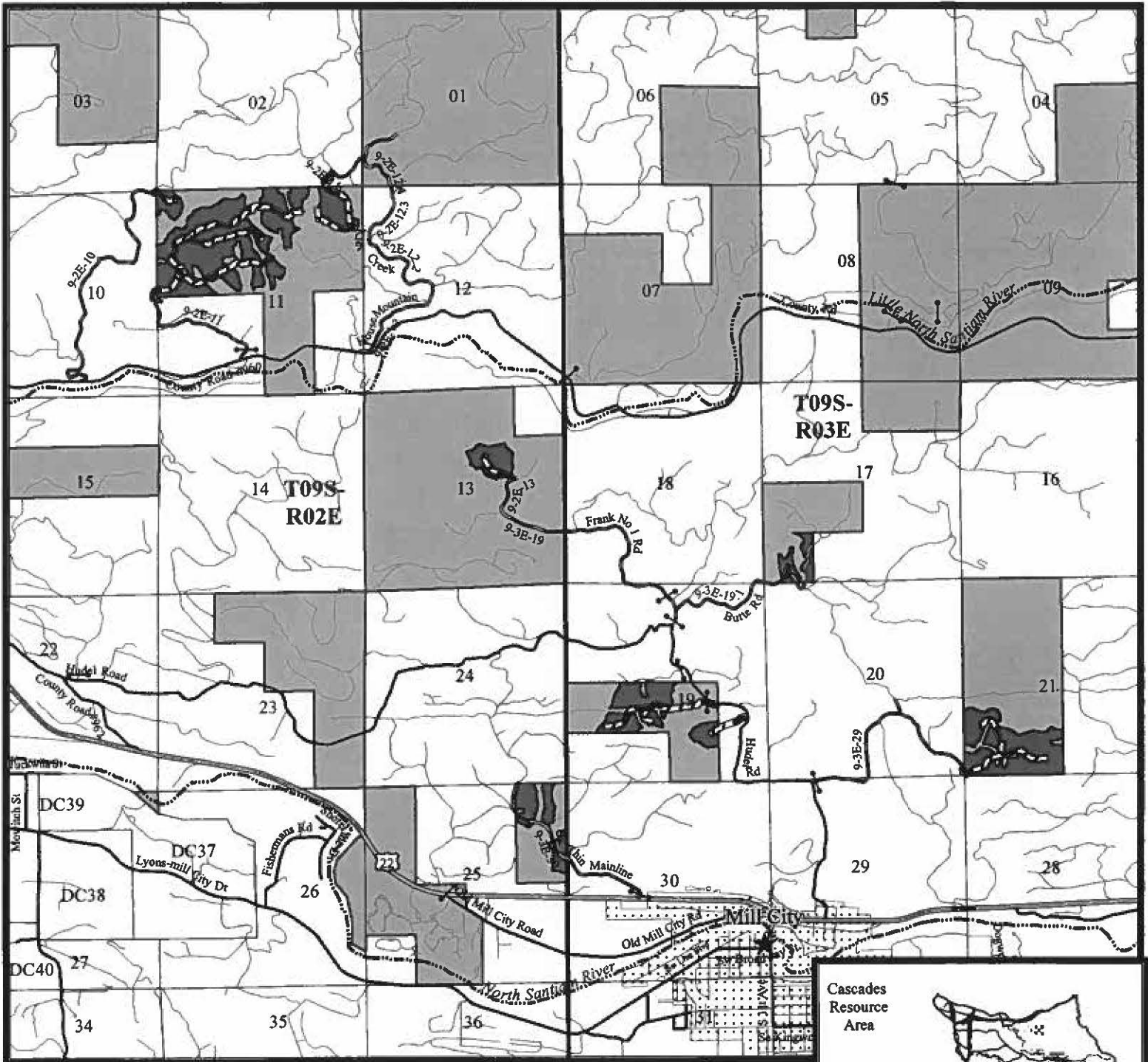

No warranty is made by the Bureau of Land Management as to the accuracy, reliability, or completeness of these data for individual or aggregate use with other data. Original data were compiled from various sources and may be updated without notification.



2 1 0 Miles



- Gate
- City
- Access Route
- Other Road
- County Road
- Road Work
- State Hwys
- Major Streams
- Partial Cut Area Unit Boundary
- Bureau of Land Management

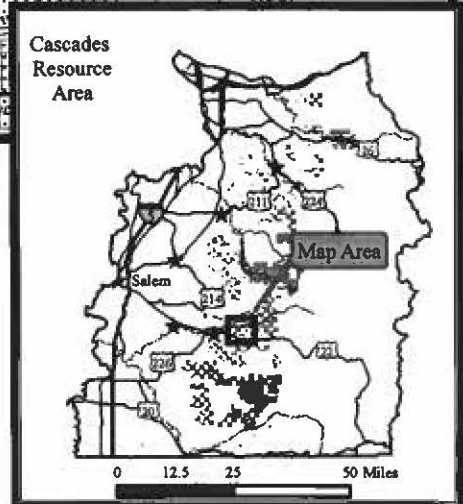

UNITED STATES  
DEPARTMENT OF THE INTERIOR  
BUREAU OF LAND MANAGEMENT

NOTICE OF REQUIREMENT FOR CERTIFICATION  
OF NONSEGREGATED FACILITIES

Bidders and offerors are cautioned as follows: by signing this bid or offer or entering into this contract or lease, as the case may be, the bidder, offeror, or contractor will be deemed to have signed and agreed to the provisions of the Certification of Nonsegregated Facilities in this solicitation. The certification provides that the bidder or offeror does not maintain or provide for his employees facilities which are segregated on a basis of race, color, religion, sex, or national origin, whether such facilities are segregated by directive or on a de facto basis. The certification also provides that he will not maintain such segregated facilities. Failure of a bidder or offeror to agree to the Certification of Nonsegregated Facilities will render his bid or offer nonresponsive to the terms of solicitations involving awards of contract exceeding \$10,000 which are not exempt from the provisions of the Equal Opportunity clause.

---

In accordance with 41 CFR 60, as amended May 19, 1967, and Executive Order No. 11246 of September 24, 1965, as amended, this notification will be included in all notices of invitations for bid, lease, offers, and requests for proposal where prospective nonexempt contracts may exceed \$10,000.

UNITED STATES  
DEPARTMENT OF THE INTERIOR  
BUREAU OF LAND MANAGEMENT

OMB CLEARANCE  
NO. 1004-0058 EXPIRES MAY 31, 1983

Location of facility where Federal Timber is expected to be processed.

**EXPORT DETERMINATION**

**INSTRUCTIONS**

Timber sale applicant forwards information to authorized officer.

In compliance with requirements of 43 CFR 5424,  I  We hereby submit the following information:

(1) Have you exported private timber from lands tributary to the above processing facility within the last 12 months?

Yes  No (If Yes, give date of last export sale.)

a. Export (date) \_\_\_\_\_

(2) Provide names of affiliates\* who have exported private timber from lands tributary to the above processing facility within the last 12 months and date of last export sale.

a. Affiliate \_\_\_\_\_ Export date \_\_\_\_\_

b. Affiliate \_\_\_\_\_ Export date \_\_\_\_\_

c. Affiliate \_\_\_\_\_ Export date \_\_\_\_\_

\*See 43 CFR 5424.0-5

Name of Firm

Signature of Signing Officer

Title

Date

(See statement on reverse)

Form 5450-17 (June 1981)

The Bureau of Land Management collects this information pursuant to the law(see 43 CFR 5400.0-3(c)).

The Bureau of Land Management uses the information to determine whether Federal timber has been substituted for exported private timber (see 43 CFR 5400.0-5(n) and 5424.0-6(c)(2)).

A Bureau of Land Management timber purchaser is obligated to report this information under provisions of the above-numbered contract (see 43 CFR 5424.1).

UNITED STATES  
DEPARTMENT OF THE INTERIOR  
BUREAU OF LAND MANAGEMENT

SELF CERTIFICATION CLAUSE  
BIDDERS STATEMENT

---

The bidder represents that he  is  is not a small business concern as defined by Title 13, Chapter 1, Part 121 of the Code of Federal Regulations, as amended.

---

(Date)

---

(Signature of Bidder)

---

Title 18 USC, sec. 1001, makes it a crime for any person knowingly and willfully to make to any department or agency of the United States any false, fictitious or fraudulent statements or representations as to any matter within its jurisdiction.

---

INSTRUCTIONS

In order to qualify for a set-aside sale, all bidders must certify to being a small business concern by submitting an executed Self Certification Clause.

The date on the Self Certification Clause and the sale date must be the same.

A Self Certification Clause must accompany the deposit to qualify for each set-aside sale. After a sale award is made,

the Self Certification Clause will be immediately returned, with the deposit, to the unsuccessful bidders but may be resubmitted to qualify for other set-aside sales offered on the same date.

The Self Certification Clause submitted by the successful bidder will be retained by the Bureau of Land Management.

Agency Forest  Bureau of Land Management	Sale Name  Powermill
--	----------------------------

**SMALL BUSINESS CERTIFICATION REQUIRED ON  
ALL PREFERENTIAL SALES OF SET-ASIDE TIMBER**

The purchaser certifies, at the time of executing timber sale Contract No. ORS040-TS12-502, Powermill, to which this statement is annexed, that in accordance with the Rules and Regulations (13 CFR 121) of the Small Business Administration (SBA):

1. His firm (a) is primarily engaged in the logging or forest products industry; (b) is independently owned and operated; (c) is not dominant in its field of operation; and (d) employs, together with its affiliates, 500 or fewer persons.
2. (a) He agrees not to sell and/or exchange more than 30 percent (50 percent in the case of Alaska) of the timber of log volume from this preferential sale to concerns not meeting SBA's small business size standard. Such timber and log volume comprises logs, bolts and pieces that are suitable for manufacture into lumber dimension and/or veneer and normally appraised as such. Timber and log volume of the preferential sale includes the contract rights, standing and down trees or portions thereof.  
  
(b) Whenever he does sell and/or exchange timber or logs from this preferential sale, records of such transactions will be maintained for a period of three years showing the name, address, and SBA size status (i.e., whether large or small) of each concern to whom the timber or logs were sold or disposed and the species, grades and volumes involved. In the event of such sale or sales, purchaser shall also require other purchasers to maintain similar records for a period of three years (OMB Approval No. 0596-0021). A signed certificate similar to this one will be obtained from each party buying such timber and will be retained for review in event of investigation.  
  
(c) If his concern is purchased by, becomes controlled by, or merged with a large business, so much of such timber and log volume from this preferential sale as is necessary will be sold (not bartered) to one or more small businesses for compliance with the 30 percent (50 percent in the case of Alaska) restriction.
3. He agrees that if he utilizes log volume from this preferential sale in the manufacture of a product, such manufacture will be done with his own facilities or those of another concern that qualifies as a small business.
4. He understands that in addition to other penalties which may be imposed for violating the foregoing, he may be declared ineligible to participate in future Federal timber sales.

Signed \_\_\_\_\_  
\_\_\_\_\_  
\_\_\_\_\_  
Date \_\_\_\_\_



Form 5440-9  
July 1990)

UNITED STATES  
DEPARTMENT OF THE INTERIOR  
BUREAU OF LAND MANAGEMENT

FORM APPROVED  
OMB NO.1004-0113  
Expires: July 31, 1992

DEPOSIT AND BID FOR  TIMBER\*  
 VEGETATIVE RESOURCE  
(Other Than Timber)

LUMP SUM SALE

Tract Number

ORS040-TS12-502

Sale Name

Powermill

Sale Notice (dated)

May 25, 2012

BLM District

SALEM

Sealed Bid for Sealed Bid Sale

Written Bid for Oral Auction Sale

In response to the above dated Sale Notice, the required deposit and bid are hereby submitted for the purchase of designated timber/vegetative resource on the tract specified above.

Required bid deposited is \$152,800.00 and is enclosed in the form of  cash  money order  bank draft  cashier's check  certified check  bid bond of corporate surety on approved list of the United States Treasury  guaranteed remittance approved by the authorized officer.

IT IS AGREED That the bid deposit shall be retained by the United States as liquidated damages if the bid is accepted and the undersigned fails to execute and return the contract, together with any required performance bond and any required payment within 30 days after the contract is received by the successful bidder. It is understood that no bid for less than the appraised price on a unit basis per species will be considered. If the bid is rejected the deposit will be returned.

BID SCHEDULE - LUMP SUM SALE

NOTE: Bidders should carefully check computations in completing the Bid Schedule

BID SUBMITTED

ORAL BID MADE

PRODUCT SPECIES	UNIT	ESTIMATED VOLUME OR QUANTITY	UNIT PRICE	TOTAL VALUE	UNIT PRICE	TOTAL VALUE
Douglas-fir	MBF	6.157	x _____ = _____		x _____ = _____	
Western hemlock	MBF	494	x _____ = _____		x _____ = _____	
Grand fir	MBF	100	x _____ = _____		x _____ = _____	
	MBF		x _____ = _____		x _____ = _____	
	MBF		x _____ = _____		x _____ = _____	
	MBF		x _____ = _____		x _____ = _____	
	MBF		x _____ = _____		x _____ = _____	
	MBF		x _____ = _____		x _____ = _____	
	MBF		x _____ = _____		x _____ = _____	
	MBF		x _____ = _____		x _____ = _____	
	MBF		x _____ = _____		x _____ = _____	
	MBF		x _____ = _____		x _____ = _____	

TOTAL PURCHASE PRICE

(Continued on reverse)

If sale contract is executed, undersigned is liable for total purchase price even though the quantity cut, removed, or designated for taking is more or less than the total estimated volume or quantity shown above. Undersigned certifies bid was arrived at by bidder or offeror independently, and was tendered without collusion with any other bidder or offeror. In submitting or confirming this bid, undersigned agrees to the foregoing provisions, applicable regulations, and certifies that he is authorized to act as, or on behalf of, the bidder.

Bid submitted on *(date)*

*(Check appropriate box, sign in ink, and complete the following)*

<input type="checkbox"/> Signature, if firm is individually owned	Name of firm <i>(type or print)</i>
<input type="checkbox"/> Signatures, if firm is a partnership	Business address, include zip code <i>(type or print)</i>
<input type="checkbox"/> Corporation organized under the state laws of	(To be completed following oral bidding)
Signature of Authorized Corporate Signing Officer	I HEREBY confirm the above oral bid By (signature)
Title	Date
Submit bid, in duplicate, to qualify for either an oral auction or sealed bid sale together with the required bid deposit made payable to the Department of the Interior-BLM	Sealed Bid - Send to District Manager. who issued the sale notice. in a sealed envelope marked on the outside: (1) "Bid for Timber" (2) Vegetative Resource Other Than Timber (3) Time bids are to be opened (4) Legal description
Oral Auction - Submit to Sales Supervisor prior to closing of qualifying period for tract.	

The Paperwork Reduction Act of 1980 (44 U.S.C. 3501 et. seq.) requires us to inform you that:

This information is being collected to obtain data relevant to the operation of this timber sale contract.  
This information will be used to administer our timber sale program.  
Response to this request is required to obtain a benefit.

#### NOTICE

The Privacy Act of 1974 and the regulation in 43 CFR 2.48(d) provide that you be furnished the following information in connection with information required by this application.

**AUTHORITY:** 38 FR 6280 and 43 CFR 5442.1

**PURPOSE:** To qualify an oral auction bidder, and then if successful, to bind bidder to certain contract conditions.

**ROUTINE USE:** To determine that an individual is qualified to participate in oral auction bidding, and, as surety that bidder will fulfill contract requirements.

**EFFECT OF NOT PROVIDING INFORMATION:** Filing this deposit and bid information is necessary only when an individual wishes to participate in a sealed or auction bid sale for timber or vegetative resources.

#### BURDEN HOURS STATEMENT

Public reporting burden for this form is estimated to average 1 hr. 15 mm. per response, including the time for reviewing instructions, gathering and maintaining data, and completing and reviewing the form. Direct comments regarding the burden estimate or any other aspect of this form to U.S Department of the Interior, Bureau of Land Management, (Alternate) Bureau Clearance Officer, (WO-771), 18 and C Streets, N.W. Washington, D.C. 20240, and the Office of Management and Budget, Paperwork Reduction Project (1004-0113), Washington, D.C. 20503.

*EQUAL OPPORTUNITY CLAUSE* - This contract is subject to the provisions of Executive Order No. 11246 of September 24, 1965, as amended, which sets forth the nondiscrimination clauses. Copies of this order may be obtained from the District Manager. 43 CFR 60-1.7(b) requires that the Equal Opportunity *Compliance Report Certification* will be completed by prospective contractors. Certification may be obtained from District Manager.

*17.LOG EXPORT* - All timber offered for sale except as noted in the *Timber Sale Notice* is restricted from export from the United States in the form of unprocessed timber and cannot be used as a substitute for exported private timber. For the purpose of this contract, unprocessed timber is defined as: (1) any logs except those of utility grade or below, such as sawlogs, peeler logs, and pulp logs; (2) cants or squares to be subsequently remanufactured exceeding eight and three quarters (8-3/4) inches in thickness; (3) split or round bolts or other roundwood not processed to standards and specifications suitable for end product use; or (4) western red cedar lumber which does not meet lumber of American Lumber Standards Grades of Number 3 dimension

or better, or Pacific Lumber Inspection Bureau R-List Grades of Number 3 common or better. Timber manufactured into the following will be considered processed.. (1) lumber and construction timbers, regardless of size, manufactured to standards and specifications suitable for end product uses; (2) chips, pulp and pulp products; (3) green or dry veneer and plywood; (4) poles and piling cut or treated for use as such; (5) cants, squares, and lumber cut for remanufacture of eight and three quarters (8-3/4) inches in thickness or less, or (6) shakes and shingles. in event purchaser wishes to sell any or all of timber restricted from export in the form of unprocessed timber. the buyer, exchanges, or recipient shall be required to comply with contractual provisions relating to "unprocessed timber.@ Special reporting, branding and painting of logs may be included in contract provisions. \*

*18.DETAILED INFORMATION* - Detailed information concerning contract provisions, hid, performance bond forms, tract location maps, and access conditions may be obtained from the District Manager. All persons interested in bidding on the products listed are encouraged to familiarize themselves with all such detailed information.